



Industrial Automation Headquarters
Delta Electronics, Inc.
Taoyuan Technology Center
No.18, Xinglong Rd., Taoyuan City,
Taoyuan County 33068, Taiwan
TEL: 886-3-362-6301 / FAX: 886-3-371-6301

Asia
Delta Electronics (Jiangsu) Ltd.
Wujiang Plant 3
1688 Jiangxing East Road,
Wujiang Economic Development Zone
Wujiang City, Jiang Su Province,
People's Republic of China (Post code: 215200)
TEL: 86-512-6340-3008 / FAX: 86-769-6340-7290

Delta Greentech (China) Co., Ltd.
238 Min-Xia Road, Pudong District,
Shanghai, P.R.C.
Post code : 201209
TEL: 86-21-58635678 / FAX: 86-21-58630003

Delta Electronics (Japan), Inc.
Tokyo Office
2-1-14 Minato-ku Shibadaimon,
Tokyo 105-0012, Japan
TEL: 81-3-5733-1111 / FAX: 81-3-5733-1211

Delta Electronics (Korea), Inc.
1511, Byucksan Digital Valley 6-cha, Gasan-dong,
Geumcheon-gu, Seoul, Korea, 153-704
TEL: 82-2-515-5303 / FAX: 82-2-515-5302

Delta Electronics Int'l (S) Pte Ltd
4 Kaki Bukit Ave 1, #05-05, Singapore 417939
TEL: 65-6747-5155 / FAX: 65-6744-9228

Delta Electronics (India) Pvt. Ltd.
Plot No 43 Sector 35, HSIIDC
Gurgaon, PIN 122001, Haryana, India
TEL : 91-124-4874900 / FAX : 91-124-4874945

Americas
Delta Products Corporation (USA)
Raleigh Office
P.O. Box 12173, 5101 Davis Drive,
Research Triangle Park, NC 27709, U.S.A.
TEL: 1-919-767-3800 / FAX: 1-919-767-8080

Delta Greentech (Brasil) S.A
Sao Paulo Office
Rua Itapeva, 26 - 3° andar Edificio Itapeva One-Bela Vista
01332-000-São Paulo-SP-Brazil
TEL: +55 11 3568-3855 / FAX: +55 11 3568-3865

Europe
Deltronics (The Netherlands) B.V.
Eindhoven Office
De Witbogt 15, 5652 AG Eindhoven, The Netherlands
TEL: 31-40-2592850 / FAX: 31-40-2592851

*We reserve the right to change the information in this catalogue without prior notice.

5011653107

2016-04



07VE

General Field Oriented Vector Control Drives VFD-VE Series User Manual



General Field Oriented Vector Control Drives VFD-VE Series User Manual

www.deltaww.com



Preface

Thank you for choosing DELTA's high-performance VFD-VE Series. The VFD-VE Series is manufactured with high-quality components and materials and incorporates the latest microprocessor technology available.

This manual is to be used for the installation, parameter setting, troubleshooting, and daily maintenance of the AC motor drive. To guarantee safe operation of the equipment, read the following safety guidelines before connecting power to the AC motor drive. Keep this operating manual at hand and distribute to all users for reference.

To ensure the safety of operators and equipment, only qualified personnel familiar with AC motor drive are to do installation, start-up and maintenance. Always read this manual thoroughly before using VFD-VE series AC Motor Drive, especially the WARNING, DANGER and CAUTION notes. Failure to comply may result in personal injury and equipment damage. If you have any questions, please contact your dealer.

PLEASE READ PRIOR TO INSTALLATION FOR SAFETY.



-
1. AC input power must be disconnected before any wiring to the AC motor drive is made.
 2. A charge may still remain in the DC-link capacitors with hazardous voltages, even if the power has been turned off. To prevent personal injury, please ensure that power has turned off before opening the AC motor drive and wait ten minutes for the capacitors to discharge to safe voltage levels.
 3. Never reassemble internal components or wiring.
 4. The AC motor drive may be destroyed beyond repair if incorrect cables are connected to the input/output terminals. Never connect the AC motor drive output terminals U/T1, V/T2, and W/T3 directly to the AC mains circuit power supply.
 5. Ground the VFD-VE using the ground terminal. The grounding method must comply with the laws of the country where the AC motor drive is to be installed. Refer to the Basic Wiring Diagram.
 6. VFD-VE series is used only to control variable speed of 3-phase induction motors, NOT for 1-phase motors or other purpose.
 7. VFD-VE series shall NOT be used for life support equipment or any life safety situation.

**WARNING!**

1. DO NOT use Hi-pot test for internal components. The semi-conductor used in AC motor drive easily damage by high-voltage.
2. There are highly sensitive MOS components on the printed circuit boards. These components are especially sensitive to static electricity. To prevent damage to these components, do not touch these components or the circuit boards with metal objects or your bare hands.
3. Only qualified persons are allowed to install, wire and maintain AC motor drives.

**CAUTION!**

1. Some parameters settings can cause the motor to run immediately after applying power.
2. DO NOT install the AC motor drive in a place subjected to high temperature, direct sunlight, high humidity, excessive vibration, corrosive gases or liquids, or airborne dust or metallic particles.
3. Only use AC motor drives within specification. Failure to comply may result in fire, explosion or electric shock.
4. To prevent personal injury, please keep children and unqualified people away from the equipment.
5. When the motor cable between AC motor drive and motor is too long, the layer insulation of the motor may be damaged. Please use a frequency inverter duty motor or add an AC output reactor to prevent damage to the motor. Refer to appendix B Reactor for details.
6. The rated voltage for AC motor drive must be $\leq 240V$ ($\leq 480V$ for 460V models) and the mains supply current capacity must be $\leq 5000A$ RMS ($\leq 10000A$ RMS for the $\geq 40hp$ (30kW) models).

Table of Contents

Preface	i
Table of Contents	iii
Chapter 1 Introduction	1-1
1.1 Receiving and Inspection	1-2
1.1.1 Nameplate Information	1-2
1.1.2 Model Explanation	1-2
1.1.3 Series Number Explanation	1-3
1.1.4 Drive Frames and Appearances	1-3
1.2 Preparation for Installation and Wiring	1-4
1.2.1 Ambient Conditions	1-4
1.2.2 Remove Keypad	1-6
1.2.3 Remove Front Cover	1-7
1.2.4 Lifting	1-8
1.3 Dimensions	1-10
Chapter 2 Installation and Wiring	2-1
2.1 Wiring	2-2
2.2 External Wiring	2-6
2.3 Main Circuit	2-7
2.3.1 Main Circuit Connection	2-7
2.3.2 Main Circuit Terminals	2-10

2.4 Control Terminals	2-12
Chapter 3 Digital Keypad Operation and Start Up	3-1
3.1 Digital Keypad KPV-CE01	3-1
3.1.1 Description of the Digital Keypad KPV-CE01	3-1
3.1.2 How to Operate the Digital Keypad KPV-CE01	3-3
3.1.3 Dimension of the Digital Keypad	3-5
3.1.4 Reference Table for the LCD Display of the Digital Keypad	3-5
3.1.5 Operation Method.....	3-6
3.2 Tuning Operations	3-7
3.2.1 Flow Chart.....	3-7
3.2.2 Explanations for the Tuning Steps.....	3-10
3.3.2.1 Step 1	3-10
3.3.2.2 Step 2	3-11
3.3.2.3 Step 3	3-12
3.3.2.4 Step 4	3-13
Chapter 4 Parameters.....	4-1
4.1 Summary of Parameter Settings.....	4-2
4.2 Version Differences	4-26
4.2.1 Version 2.02	4-26
4.2.2 Version 2.04	4-29
4.2.3 Version 2.05	4-38
4.3 Description of Parameter Settings	4-47
Chapter 5 Troubleshooting	5-1
5.1 Over Current (OC)	5-1
5.2 Ground Fault.....	5-2

5.3 Over Voltage (OV).....	5-2
5.4 Low Voltage (Lv)	5-3
5.5 Over Heat (oH1, oH2, oH3).....	5-4
5.6 Overload.....	5-4
5.7 Display of KPV-CE01 is Abnormal	5-5
5.8 Phase Loss (PHL)	5-5
5.9 Motor cannot Run.....	5-6
5.10 Motor Speed cannot be Changed.....	5-7
5.11 Motor Stalls during Acceleration	5-8
5.12 The Motor does not Run as Expected	5-8
5.13 Electromagnetic/Induction Noise	5-9
5.14 Environmental Condition	5-9
5.15 Affecting Other Machines	5-10
Chapter 6 Fault Code Information and Maintenance.....	6-1
6.1 Fault Code Information.....	6-1
6.1.1 Common Problems and Solutions.....	6-1
6.1.2 Reset	6-6
6.2 Maintenance and Inspections.....	6-7
Appendix A Specifications	A-1
Appendix B Accessories	B-1
B.1 All Brake Resistors & Brake Units Used in AC Motor Drives.....	B-1
B.1.1 Dimensions and Weights for Brake Resistors	B-4
B.1.2 Specifications for Brake Unit	B-6
B.1.3 Dimensions for Brake Unit.....	B-7

B.2 No-fuse Circuit Breaker Chart	B-9
B.3 Fuse Specification Chart	B-10
B.4 AC Reactor.....	B-11
B.4.1 AC Input Reactor Recommended Value	B-11
B.4.2 AC Output Reactor Recommended Value	B-11
B.4.3 Applications for AC Reactor.....	B-13
B.5 Zero Phase Reactor (RF220X00A)	B-15
B.6 DC Choke Recommended Values.....	B-16
B.7 Remote Controller RC-01	B-17
B.8 PG Card (for Encoder)	B-18
B.8.1 EMV-PG01X	B-18
B.8.2 EMV-PG01O	B-22
B.8.3 EMV-PG01L.....	B-27
B.9 AMD-EMI Filter Cross Reference	B-31
B.9.1 Dimensions	B-34
B.10 Multi-function I/O Extension Card	B-41
B.10.1 Functions	B-41
B.10.2 Dimensions	B-43
B.10.3 Wiring.....	B-43
Appendix C How to Select the Right AC Motor Drive	C-1
C.1 Capacity Formulas	C-1
C.2 General Precaution	C-4
C.3 How to Choose a Suitable Motor.....	C-5

Chapter 1 Introduction

The AC motor drive should be kept in the shipping carton or crate before installation. In order to retain the warranty coverage, the AC motor drive should be stored properly when it is not to be used for an extended period of time. Storage conditions are:



CAUTION!

-
1. Store in a clean and dry location free from direct sunlight or corrosive fumes.
 2. Store within an ambient temperature range of -10°C to $+40^{\circ}\text{C}$.
 3. Store within a relative humidity range of 0% to 90% and non-condensing environment.
 4. Store within an air pressure range of 86 kPA to 106kPA.
 5. DO NOT place on the ground directly. It should be stored properly. Moreover, if the surrounding environment is humid, you should put exsiccator in the package.
 6. DO NOT store in an area with rapid changes in temperature. It may cause condensation and frost.
 7. If the AC motor drive is stored for more than 3 months, the temperature should not be higher than 30°C . Storage longer than one year is not recommended, it could result in the degradation of the electrolytic capacitors.
 8. When the AC motor drive is not used for longer time after installation on building sites or places with humidity and dust, it's best to move the AC motor drive to an environment as stated above.

1.1 Receiving and Inspection

This VFD-VE AC motor drive has gone through rigorous quality control tests at the factory before shipment. After receiving the AC motor drive, please check for the following:

- Check to make sure that the package includes an AC motor drive, the User Manual/Quick Start and CD.
- Inspect the unit to assure it was not damaged during shipment.
- Make sure that the part number indicated on the nameplate corresponds with the part number of your order.

1.1.1 Nameplate Information

Example for 5HP/3.7kW 3-phase 230V AC motor drive

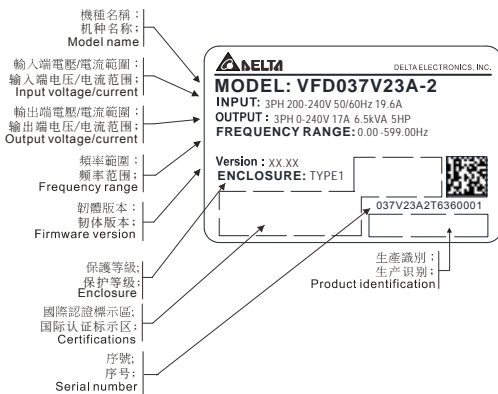

1.1.2 Model Explanation

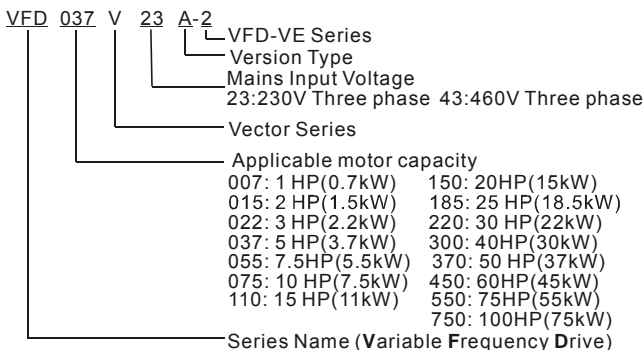

1.1.3 Series Number Explanation

037V23A2 T 7 36 0001

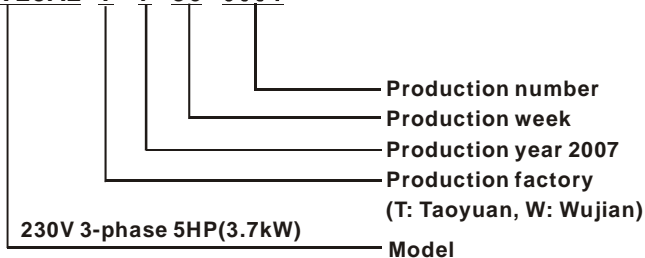

If the nameplate information does not correspond to your purchase order or if there are any problems, please contact your distributor.

1.1.4 Drive Frames and Appearances

1-5HP/0.75-3.7kW (Frame B)

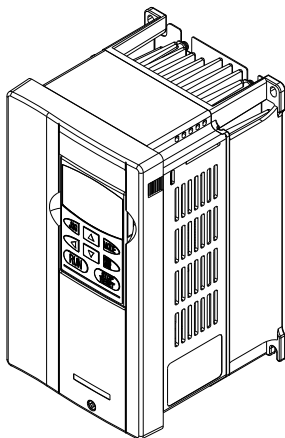

7.5-15HP/5.5-11kW (Frame C)

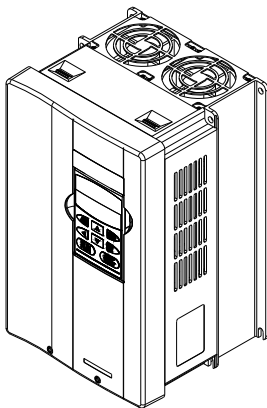

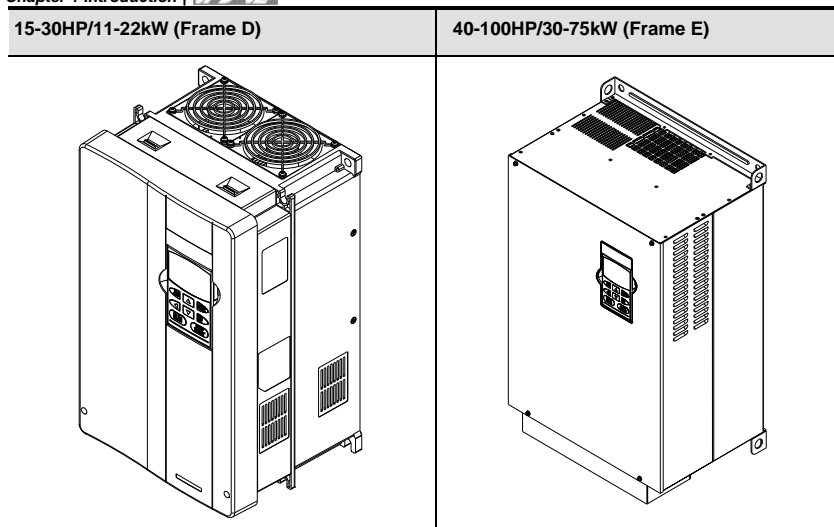

Frame	Power range	Models
B (B1)	1-3hp (0.75-2.2kW)	VFD007V23A/43A-2, VFD015V23A/43A-2, VFD022V23A/43A-2
B (B2)	5hp (3.7kW)	VFD037V23A/43A-2
C	7.5-15hp (5.5-11kW)	VFD055V23A/43A-2, VFD075V23A/43A-2, VFD110V43B-2
D	15-30hp (11-22kW)	VFD110V23A/43A-2, VFD150V23A/43A-2, VFD185V23A/43A-2, VFD220V23A/43A-2
E (E1)	40-60hp (30-45kW)	VFD300V43A-2, VFD370V43A-2, VFD450V43A-2
E (E2)	40-100hp (30-75kW)	VFD300V23A-2, VFD370V23A-2, VFD550V43C-2, VFD750V43C-2

Please refer to Chapter 1.3 for exact dimensions.

1.2 Preparation for Installation and Wiring

1.2.1 Ambient Conditions

Install the AC motor drive in an environment with the following conditions:

1.2 Preparation for Installation and Wiring

1.2.1 Ambient Conditions

Install the AC motor drive in an environment with the following conditions:

Operation	Air Temperature:	-10 ~ +40°C (14 ~ 122°F)
	Relative Humidity:	<90%, no condensation allowed
	Atmosphere pressure:	86 ~ 106 kPa
	Installation Site Altitude:	<1000m
	Vibration:	<20Hz: 9.80 m/s ² (1G) max 20 ~ 50Hz: 5.88 m/s ² (0.6G) max
Storage Transportation	Temperature:	-20°C ~ +60°C (-4°F ~ 140°F)
	Relative Humidity:	<90%, no condensation allowed
	Atmosphere pressure:	86 ~ 106 kPa
	Vibration:	<20Hz: 9.80 m/s ² (1G) max 20 ~ 50Hz: 5.88 m/s ² (0.6G) max
Pollution Degree	2: good for a factory type environment.	

Minimum Mounting Clearances

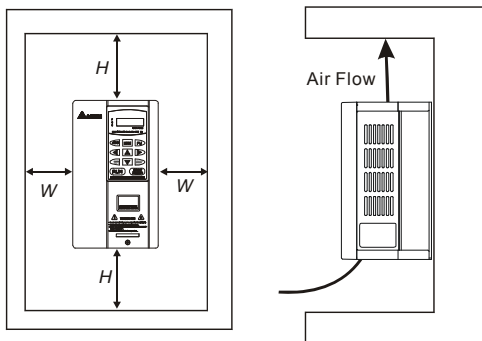

HP	W mm (inch)	H mm (inch)
1-5HP	50 (2)	150 (6)
7.5-20HP	75 (3)	175 (7)
25-75HP	75 (3)	200 (8)
100HP and above	75 (3)	250 (10)

**CAUTION!**

1. Operating, storing or transporting the AC motor drive outside these conditions may cause damage to the AC motor drive.
2. Failure to observe these precautions may void the warranty!
3. Mount the AC motor drive vertically on a flat vertical surface object by screws. Other directions are not allowed.
4. The AC motor drive will generate heat during operation. Allow sufficient space around the unit for heat dissipation.
5. The heat sink temperature may rise to 90°C when running. The material on which the AC motor drive is mounted must be noncombustible and be able to withstand this high temperature.
6. When AC motor drive is installed in a confined space (e.g. cabinet), the surrounding temperature must be within -10 ~ 40°C with good ventilation. DO NOT install the AC motor drive in a space with bad ventilation.
7. When installing multiple AC more drives in the same cabinet, they should be adjacent in a row with enough space in-between. When installing one AC motor drive below another one, use a metal separation between the AC motor drives to prevent mutual heating.
8. Prevent fiber particles, scraps of paper, saw dust, metal particles, etc. from adhering to the heatsink.

1.2.2 Remove Keypad

1-5HP/0.75-3.7kW (Frame B)

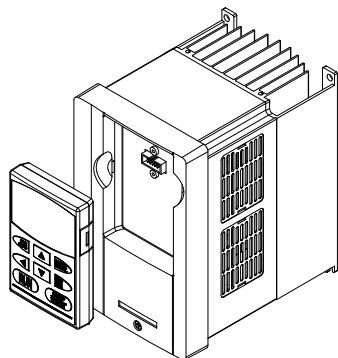

7.5-15HP/5.5-11kW (Frame C)

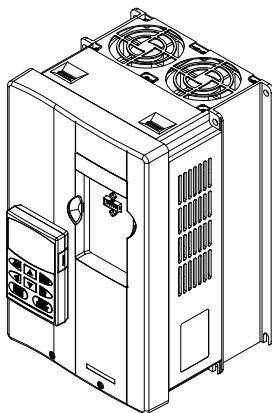

15-30HP/11-22kW (Frame D)

40-100HP/30-75kW (Frame E)

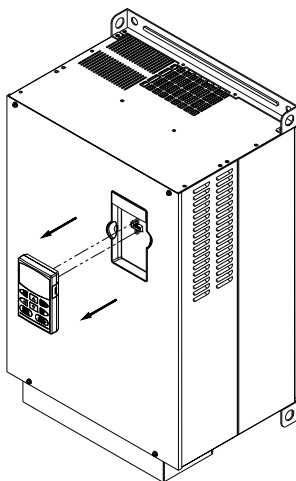
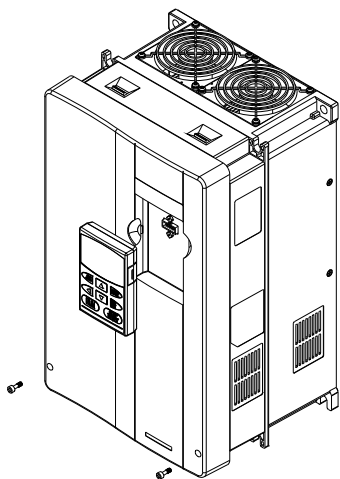

1.2.3 Remove Front Cover

1-5HP/0.75-3.7kW (Frame B)

7.5-15HP/5.5-11kW (Frame C)

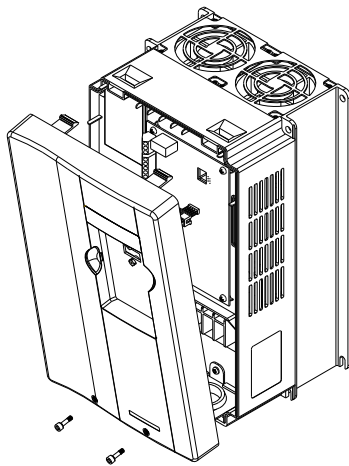
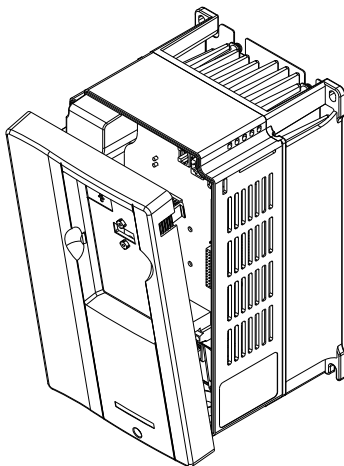

15-30HP/11-22kW (Frame D)

40-100HP/30-75kW (Frame E)

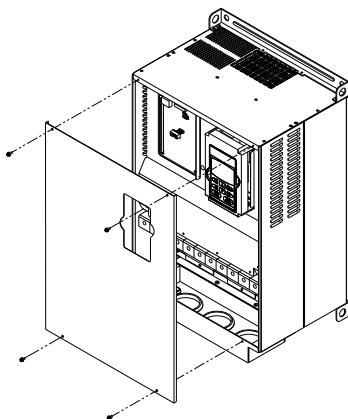
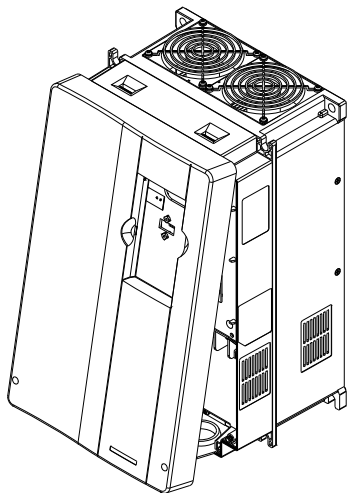

1.2.4 Lifting

Please carry only fully assembled AC motor drives as shown in the following.

For 40-100HP (Frame E and E1)

Step 1

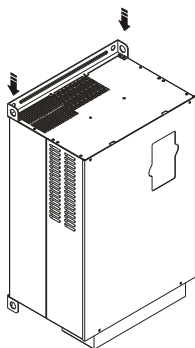

Step 2

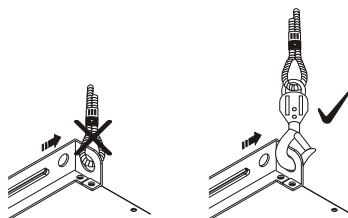

Step 3

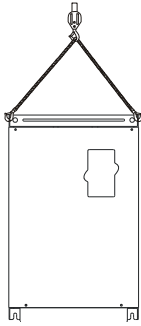

Step 4

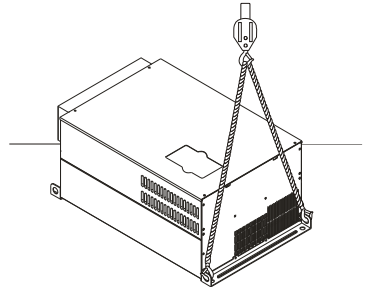

1.3 Dimensions

Frame B

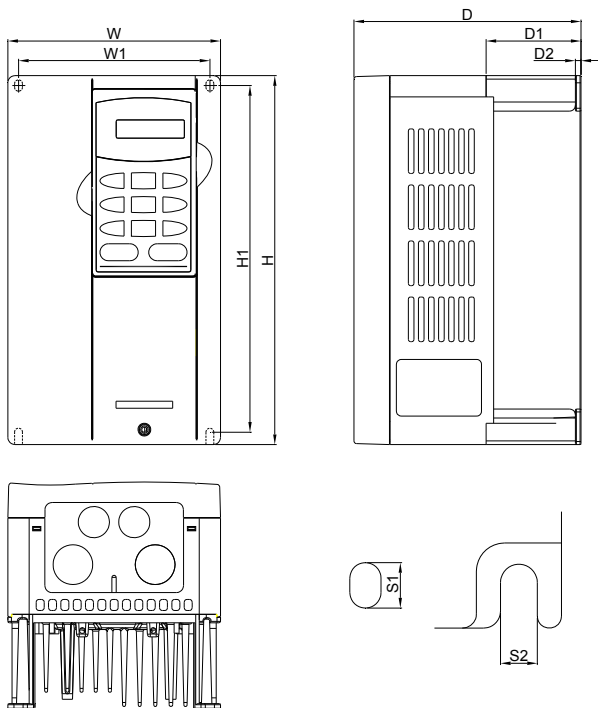

Unit: mm[inch]

Frame	W	W1	H	H1	D	D1	D2	S1	S2
B1	150.0 [5.91]	135.0 [5.32]	260.0 [10.24]	244.3 [9.63]	160.2 [6.31]	67.0 [2.64]	4.0 [0.16]	8.0 [0.32]	6.5 [0.26]
B2	150.0 [5.91]	135.0 [5.32]	272.1 [10.72]	244.3 [9.63]	183.7 [7.24]	67.0 [2.64]	4.0 [0.16]	8.0 [0.32]	6.5 [0.26]

 **NOTE**

Frame B1: VFD007V23A/43A-2, VFD015V23A/43A-2, VFD022V23A/43A-2

Frame B2: VFD037V23A/43A-2

Frame C

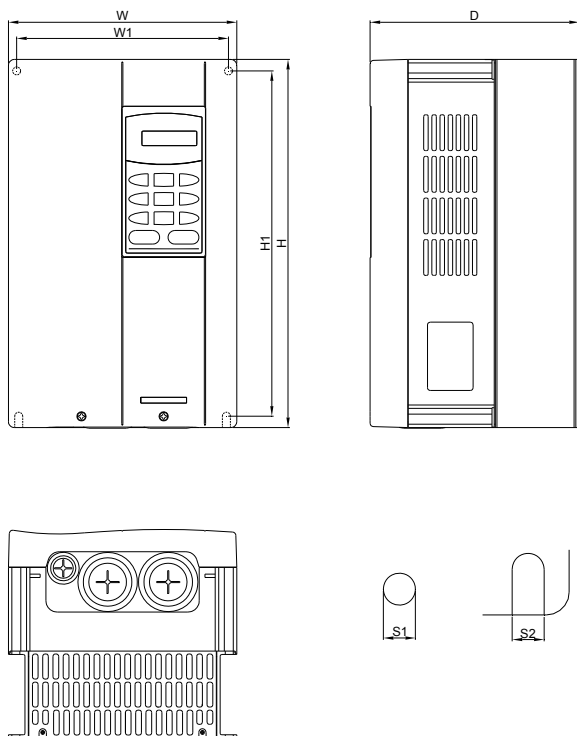

Unit: mm[inch]

Frame	W	W1	H	H1	D	-	-	S1	S2
C	200.0 [7.88]	185.6 [7.31]	323.0 [12.73]	244.3 [9.63]	160.2 [6.31]	-	-	7.0 [0.28]	7.0 [0.28]



Frame C: VFD055V23A/43A-2, VFD075V23A/43A-2, VFD110V43B-2

Frame D

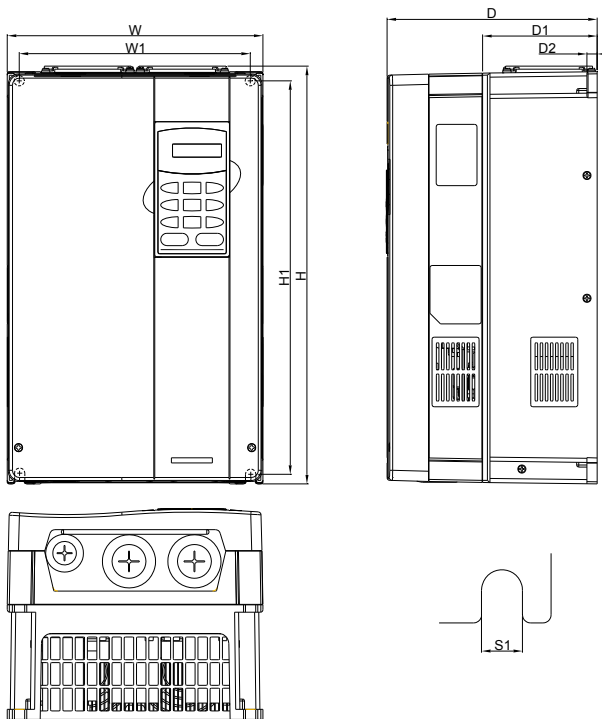

Unit: mm[inch]

Frame	W	W1	H	H1	D	D1	D2	S1	-
D	250.0 [9.85]	226.0 [8.90]	408.2 [16.07]	384.0 [15.13]	205.4 [8.08]	110.0 [4.33]	10.0 [0.39]	10.0 [0.39]	-



Frame D: VFD110V23A/43A-2, VFD150V23A/43A-2, VFD185V23A/43A-2, VFD220V23A/43A-2

Frame E

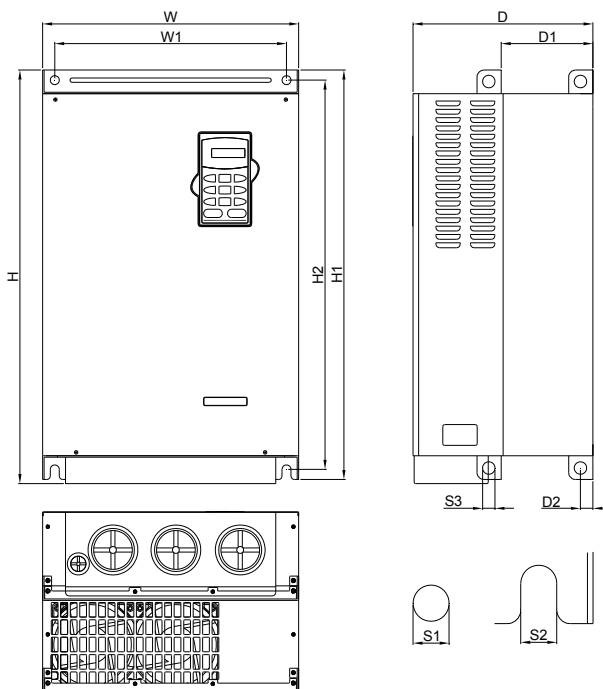

Unit: mm[inch]

Frame	W	W1	H	H1	H2	D	D1	D2	S1	S2	S3
E1	370.0 [14.57]	335.0 [13.19]	-	589.0 [23.19]	560.0 [22.05]	260.0 [10.24]	132.5 [5.22]	18.0 [0.71]	13.0 [0.51]	13.0 [0.51]	18.0 [0.71]
E2	370.0 [14.57]	335.0 [13.19]	595.0 [23.43]	589.0 [23.19]	560.0 [22.05]	260.0 [10.24]	132.5 [5.22]	18.0 [0.71]	13.0 [0.51]	13.0 [0.51]	18.0 [0.71]

 **NOTE**

Frame E1: VFD300V43A-2, VFD370V43A-2, VFD450V43A-2

Frame E2: VFD300V23A-2, VFD370V23A-2, VFD550V43C-2, VFD750V43C-2

This page intentionally left blank

Chapter 2 Installation and Wiring

After removing the front cover (see chapter 1.2.3 for details), check if the power and control terminals are clear. Be sure to observe the following precautions when wiring.

■ General Wiring Information

Applicable Codes

All VFD-VE series are Underwriters Laboratories, Inc. (UL) and Canadian Underwriters Laboratories (cUL) listed, and therefore comply with the requirements of the National Electrical Code (NEC) and the Canadian Electrical Code (CEC).

Installation intended to meet the UL and cUL requirements must follow the instructions provided in "Wiring Notes" as a minimum standard. Follow all local codes that exceed UL and cUL requirements. Refer to the technical data label affixed to the AC motor drive and the motor nameplate for electrical data.

The "Line Fuse Specification" in Appendix B, lists the recommended fuse part number for each VFD-VE Series part number. These fuses (or equivalent) must be used on all installations where compliance with U.L. standards is a required.



CAUTION!

-
1. Make sure that power is only applied to the R/L1, S/L2, T/L3 terminals. Failure to comply may result in damage to the equipment. The voltage and current should lie within the range as indicated on the nameplate.
 2. Check following items after finishing the wiring:
 - A. Are all connections correct?
 - B. No loose wires?
 - C. No short-circuits between terminals or to ground?



DANGER!

-
1. A charge may still remain in the DC bus capacitors with hazardous voltages even if the power has been turned off. To prevent personal injury, please ensure that the power is turned off and wait ten minutes for the capacitors to discharge to safe voltage levels before opening the AC motor drive.
 2. All the units must be grounded directly to a common ground terminal to prevent lightning strike or electric shock.
 3. Only qualified personnel familiar with AC motor drives is allowed to perform installation, wiring and commissioning.
 4. Make sure that the power is off before doing any wiring to prevent electric shock.

2.1 Wiring

Users must connect wires according to the circuit diagrams on the following pages. Do not plug a modem or telephone line to the RS-485 communication port or permanent damage may result. The pins 1 & 2 are the power supply for the optional copy keypad KPV-CE01 only and should not be used for RS-485 communication.

Figure 1 for models of VFD-VE Series (10 HP/7.5kW and below)
VFD007V23A/43A-2, VFD015V23A/43A-2, VFD022V23A/43A-2, VFD037V23A/43A-2,
VFD055V23A/43A-2, VFD075V23A/43A-2, VFD110V43B-2, VFD110V23A/43A-2

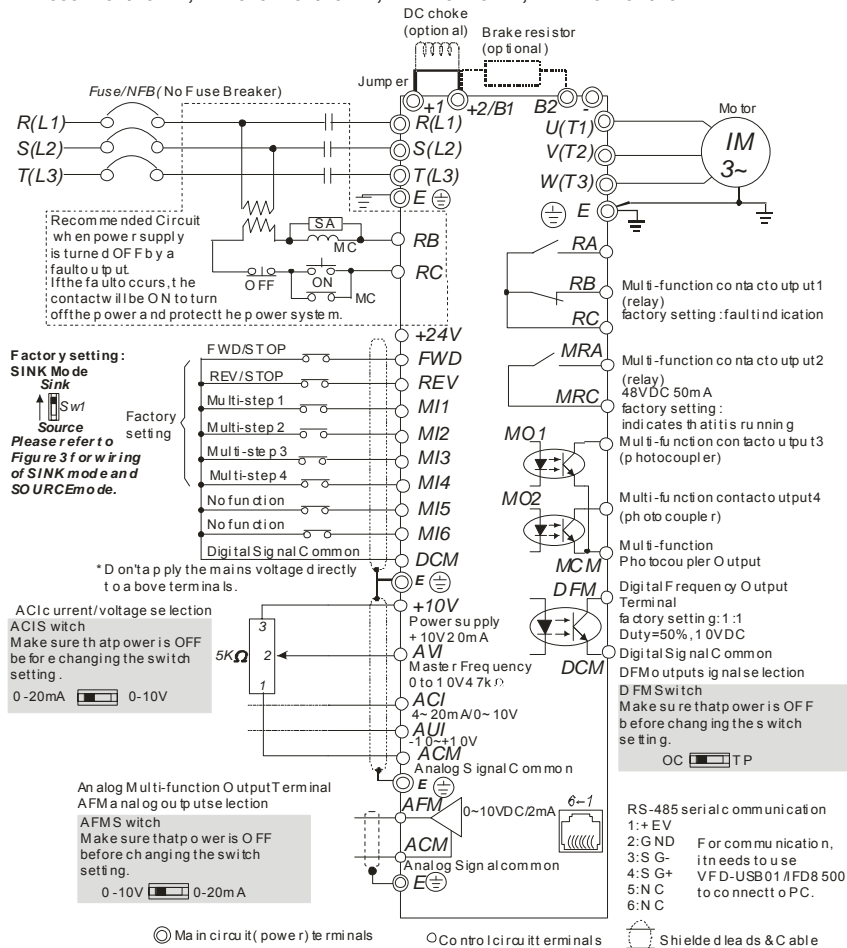

⊙ Main circuit (power) terminals ○ Control circuit terminals ⚡ Shielded leads & Cable

NOTE The brake resistor is built-in to model VFD110V43B-2.

Figure 2 for models of VFD-VE Series (15HP/11kW and above)
 VFD150V23A/43A-2, VFD185V23A/43A-2, VFD220V23A/43A-2, VFD300V43A-2, VFD370V43A-2,
 VFD450V43A-2, VFD300V23A-2, VFD370V23A-2, VFD550V43C-2, VFD750V43C-2

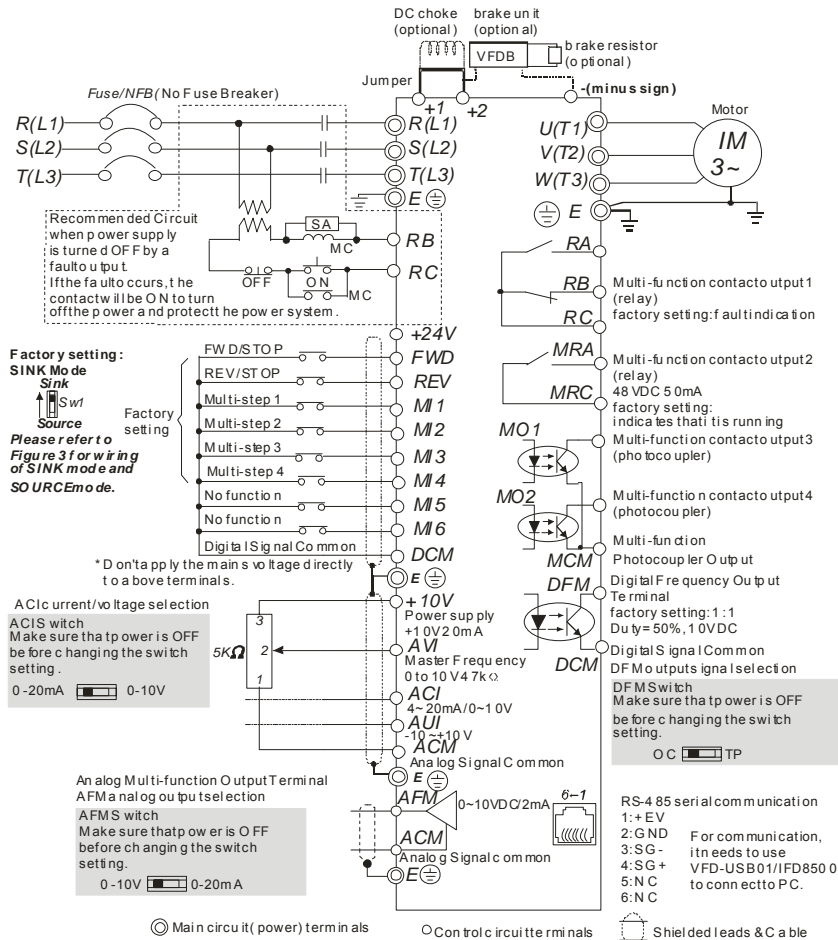

○ Main circuit (power) terminals ○ Control circuit terminals ⊕ Shielded leads & Cable

NOTE The brake resistor is built-in to model VFD110V43B-2.

Figure 3 Wiring for SINK(NPN) mode and SOURCE(PNP) mode

SINK/NPN Mode

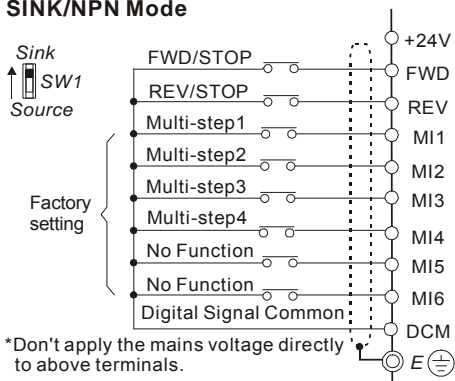

SOURCE/PNP Mode

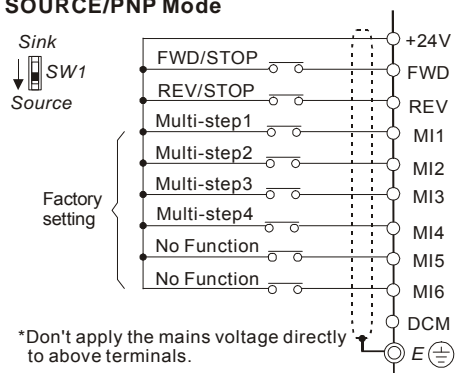

**CAUTION!**

-
1. The wiring of main circuit and control circuit should be separated to prevent erroneous actions.
 2. Please use shield wire for the control wiring and not to expose the peeled-off net in front of the terminal.
 3. Please use the shield wire or tube for the power wiring and ground the two ends of the shield wire or tube.

2.2 External Wiring

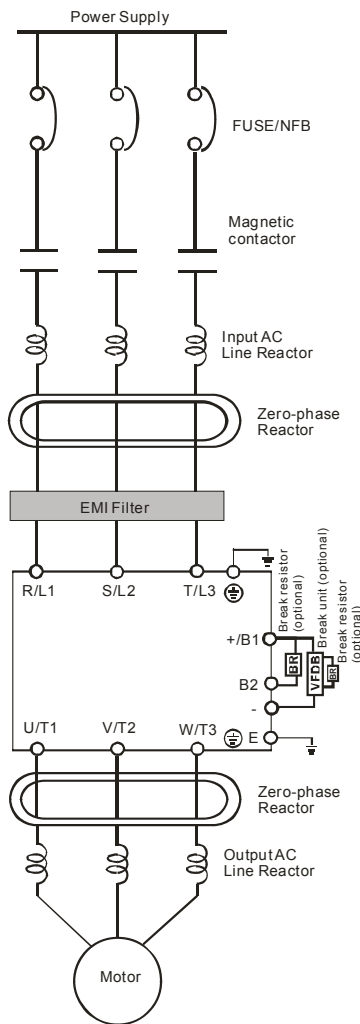

Items	Explanations
Power supply	Please follow the specific power supply requirements shown in Appendix A.
Fuse/NFB (Optional)	There may be an inrush current during power up. Please check the chart of Appendix B and select the correct fuse with rated current. Use of an NFB is optional.
Magnetic contactor (Optional)	Please do not use a Magnetic contactor as the I/O switch of the AC motor drive, as it will reduce the operating life cycle of the AC drive.
Input AC Line Reactor (Optional)	Used to improve the input power factor, to reduce harmonics and provide protection from AC line disturbances (surges, switching spikes, short interruptions, etc.). AC line reactor should be installed when the power supply capacity is 500kVA or more or advanced capacity is activated. The wiring distance should be $\leq 10m$. Refer to appendix B for details.
Zero-phase Reactor (Ferrite Core Common Choke) (Optional)	Zero phase reactors are used to reduce radio noise especially when audio equipment is installed near the inverter. Effective for noise reduction on both the input and output sides. Attenuation quality is good for a wide range from AM band to 10MHz. Appendix B specifies the zero phase reactor. (RF220X00A)
EMI filter (Optional)	To reduce electromagnetic interference, please refer to Appendix B for more details.
Brake Resistor (Optional)	Used to reduce the deceleration time of the motor. Please refer to the chart in Appendix B for specific Brake Resistors.
Output AC Line Reactor (Optional)	Motor surge voltage amplitude depends on motor cable length. For applications with long motor cable ($>20m$), it is necessary to install a reactor at the inverter output side.

2.3 Main Circuit

2.3.1 Main Circuit Connection

Figure 1 for the main terminals

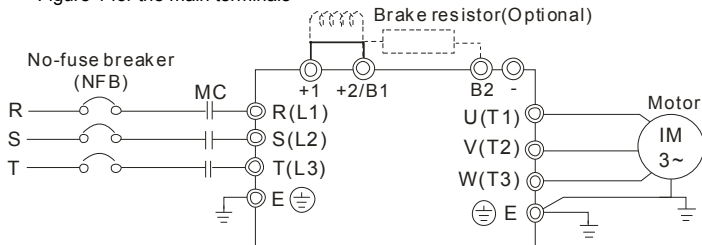
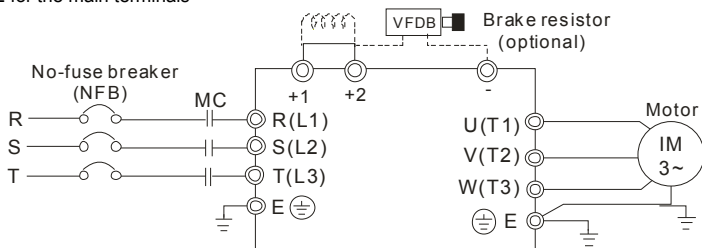



Figure 2 for the main terminals



Terminal Symbol	Explanation of Terminal Function
R/L1, S/L2, T/L3	AC line input terminals (1-phase/3-phase)
U/T1, V/T2, W/T3	AC drive output terminals for connecting 3-phase induction motor
+1, +2	Connections for DC Choke (optional)
+2/B1, B2	Connections for Brake Resistor (optional)
+2~(-), +2/B1~(-)	Connections for External Brake Unit (VFDB series)
	Earth connection, please comply with local regulations.

Mains power terminals (R/L1, S/L2, T/L3)

- Connect these terminals (R/L1, S/L2, T/L3) via a no-fuse breaker or earth leakage breaker to 3-phase AC power (some models to 1-phase AC power) for circuit protection. It is unnecessary to consider phase-sequence.
- It is recommended to add a magnetic contactor (MC) in the power input wiring to cut off power quickly and reduce malfunction when activating the protection function of AC motor drives. Both ends of the MC should have an R-C surge absorber.
- Please make sure to fasten the screw of the main circuit terminals to prevent sparks which is made by the loose screws due to vibration.
- Please use voltage and current within the regulation shown in Appendix A.
- When using leakage-current breaker to prevent leakage current,
- Do NOT run/stop AC motor drives by turning the power ON/OFF. Run/stop AC motor drives by RUN/STOP command via control terminals or keypad. If you still need to run/stop AC drives by turning power ON/OFF, it is recommended to do so only ONCE per hour.
- Do NOT connect 3-phase models to a 1-phase power source.

Output terminals for main circuit (U, V, W)

- When the AC drive output terminals U/T1, V/T2, and W/T3 are connected to the motor terminals U/T1, V/T2, and W/T3, respectively, the motor will rotate counterclockwise (as viewed on the shaft end of the motor) when a forward operation command is received. To permanently reverse the direction of motor rotation, switch over any of the two motor leads.

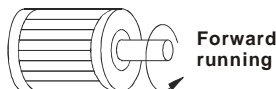

- DO NOT connect phase-compensation capacitors or surge absorbers at the output terminals of AC motor drives.
- With long motor cables, high capacitive switching current peaks can cause over-current, high leakage current or lower current readout accuracy. To prevent this, the motor cable should be less than 20m for 3.7kW models and below. And the cable should be less than 50m for 5.5kW models and above. For longer motor cables use an AC output reactor.
- Use well-insulated motor, suitable for inverter operation.

Terminals [+1, +2] for connecting DC reactor

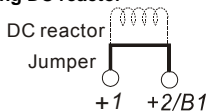

- To improve power factor and reduce harmonics connect a DC reactor between terminals [+1, +2]. Please remove the jumper before connecting the DC reactor.



NOTE Models of 15kW and above have a built-in DC reactor.

Terminals [+2/B1, B2] for connecting brake resistor and terminals [+1, +2/B1] for connecting external brake unit

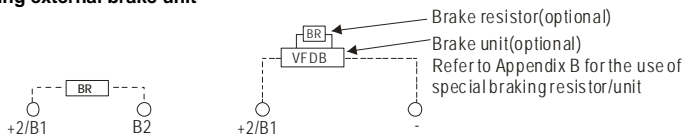

- Connect a brake resistor or brake unit in applications with frequent deceleration ramps, short deceleration time, too low brake torque or requiring increased brake torque.
- If the AC motor drive has a built-in brake chopper (all models of 11kW and below), connect the external brake resistor to the terminals [+2/B1, B2].
- Models of 15kW and above don't have a built-in brake chopper. Please connect an external optional brake unit (VFDB-series) and brake resistor. Refer to VFDB series user manual for details.
- Connect the terminals [+ (P), - (N)] of the brake unit to the AC motor drive terminals [+2(+2/B1), -]. The length of wiring should be less than 5m with twisted cable.
- When not used, please leave the terminals [+2/B1, -] open.



WARNING!

1. Short-circuiting [B2] or [-] to [+2/B1] can damage the AC motor drive.

Grounding terminals (⊕)

- Make sure that the leads are connected correctly and the AC drive is properly grounded. (Ground resistance should not exceed 0.1Ω .)
- Use ground leads that comply with local regulations and keep them as short as possible.
- Multiple VFD-VE units can be installed in one location. All the units should be grounded directly to a common ground terminal, as shown in the figure below. **Ensure there are no ground loops.**

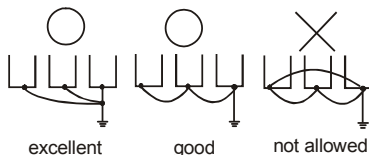

2.3.2 Main Circuit Terminals

Frame B

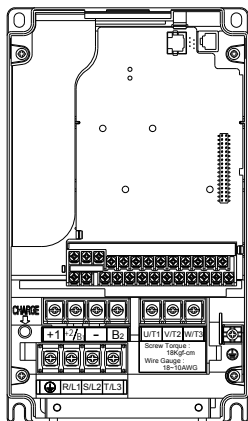

Main circuit terminals

R/L1, S/L2, T/L3, U/T1, V/T2, W/T3, \oplus , +1, +2/B1, -, B2

Models	Wire	Torque	Wire Type
VFD007V23A-2	14-10 AWG (2.1-5.3mm ²)	18kgf-cm (15.6in-lbf)	Stranded copper only, 75°C
VFD007V43A-2			
VFD015V23A-2			
VFD015V43A-2			
VFD022V23A-2			
VFD022V43A-2			
VFD037V23A-2			
VFD037V43A-2			

Frame C

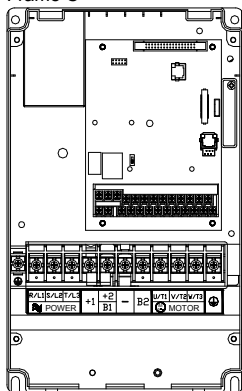

Main circuit terminals

R/L1, S/L2, T/L3, U/T1, V/T2, W/T3, \oplus , +1, +2/B1, -, B2

Models	Wire	Torque	Wire Type
VFD055V23A-2	12-8 AWG (3.3-8.4mm ²)	30kgf-cm (26in-lbf)	Stranded copper only, 75°C
VFD075V23A-2			
VFD110V43B-2			
VFD055V43A-2			
VFD075V43A-2			

Frame D

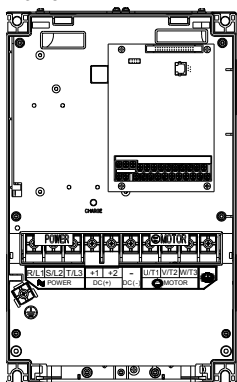

Main circuit terminals

R/L1, S/L2, T/L3, U/T1, V/T2, W/T3, , +1, +2, -

Models	Wire	Torque	Wire Type
VFD110V23A-2	8-2 AWG (8.4-33.6mm ²)	30kgf-cm (26in-lbf)	Stranded copper only, 75°C
VFD110V43A-2			
VFD150V43A-2			
VFD150V23A-2			
VFD185V23A-2			
VFD185V43A-2			
VFD220V43A-2			
VFD220V23A-2			

Frame E

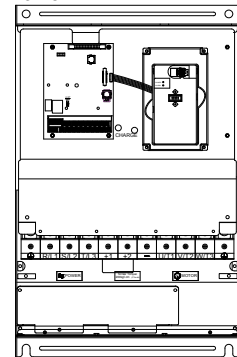

Main circuit terminals

R/L1, S/L2, T/L3, U/T1, V/T2, W/T3, , +1, +2, -

Models	Wire	Torque	Wire Type
VFD300V43A-2	4-2 AWG (21.2-33.6mm ²)	57kgf-cm (49in-lbf)	Stranded copper only, 75°C
VFD370V43A-2			
VFD450V43A-2		200kgf-cm (173in-lbf)	
VFD300V23A-2			
VFD370V23A-2			
VFD550V43C-2			
VFD750V43C-2			



To connect 6 AWG (13.3 mm²) wires, use Recognized Ring Terminals

2.4 Control Terminals

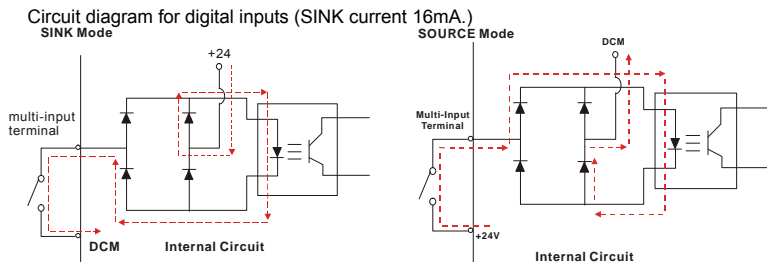

The Position of the Control Terminals

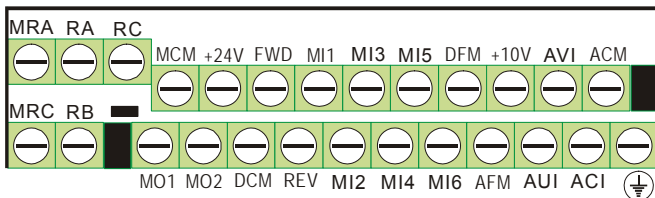

Terminal symbols and functions

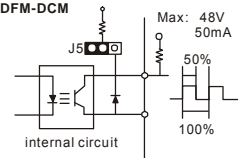
Terminal Symbol	Terminal Function	Factory Settings (SINK) ON: Connect to DCM
FWD	Forward-Stop Command	ON: Run in FWD direction OFF: Stop acc. to Stop Method
REV	Reverse-Stop Command	ON: Run in REV direction OFF: Stop acc. to Stop Method
+24V	DC Voltage Source	+24VDC, 80mA, used for SOURCE mode.
MI1	Multi-function Input 1	Refer to Pr.02-01 to Pr.02-06 for programming the Multi-function Inputs. ON: the activation current is 6.5mA. OFF: leakage current tolerance is 10 μ A.
MI2	Multi-function Input 2	
MI3	Multi-function Input 3	
MI4	Multi-function Input 4	
MI5	Multi-function Input 5	
MI6	Multi-function Input 6	
DFM	Digital Frequency Meter (Open Collector Output) 	Pulse voltage output monitor signal, proportional to output frequency Duty-cycle: 50% Ratio: Pr.02-18 Min. load: 4.7k Ω Max. current: 50mA Max. voltage: 48Vdc Jumper: DFM jumper, factory setting is OC
DCM	Digital Signal Common	Common for digital inputs and used for SINK mode.
RA	Multi-function Relay Output 1 (N.O.) a	Resistive Load: 5A(N.O.)/3A(N.C.) 240VAC 5A(N.O.)/3A(N.C.) 24VDC Inductive Load: 1.5A(N.O.)/0.5A(N.C.) 240VAC 1.5A(N.O.)/0.5A(N.C.) 24VDC To output monitor signal, including in operation, frequency arrival, overload and etc. Refer to Pr.02-11~02-12 for programming
RB	Multi-function Relay Output 1 (N.C.) b	
RC	Multi-function Relay Common	
MRA	Multi-function Relay Output 2 (N.O.) a	
MRC	Multi-function Relay Common	

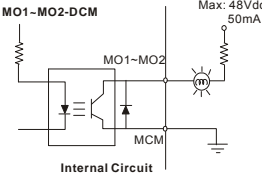
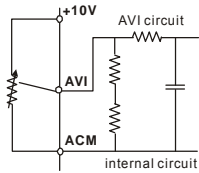
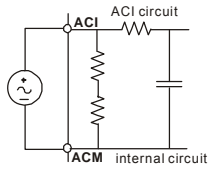
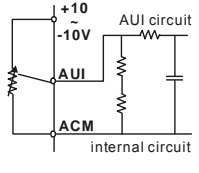
Terminal Symbol	Terminal Function	Factory Settings (SINK) ON: Connect to DCM
+10V	Potentiometer Power Supply	+10VDC 20mA (variable resistor 3-5kohm)
MCM	Multi-function Output Common (Photocoupler)	Max. 48VDC 50mA
MO1	Multi-function Output 1 (Photocoupler)	Maximum 48VDC, 50mA Refer to Pr.02-13 to Pr.02-14 for programming
MO2	Multi-function Output 2 (Photocoupler)	
AVI	Analog voltage Input 	Impedance: 200kΩ Resolution: 12 bits Range: 0 ~ 10VDC = 0 ~ Max. Output Frequency (Pr.01-00) Set-up: Pr.03-00 ~ Pr.03-02
ACI	Analog current Input 	Impedance: 250Ω Resolution: 12 bits Range: 4 ~ 20mA/0~10V = 0 ~ Max. Output Frequency (Pr.01-00) Set-up: Pr.03-00 ~ Pr.03-02 Jumper: ACI jumper, factory setting is 4-20mA
AUI	Auxiliary analog voltage input 	Impedance: 200kΩ Resolution: 12 bits Range: -10 ~ +10VDC = 0 ~ Max. Output Frequency (Pr.01-00) Set-up: Pr.03-00 ~ Pr.03-02

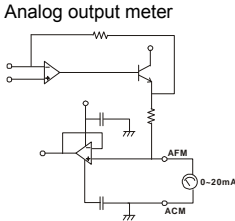
Terminal Symbol	Terminal Function	Factory Settings (SINK) ON: Connect to DCM
AFM	Analog output meter 	Impedance: 18.5kΩ (voltage output) 1.1mΩ (current output) Output current: 20mA max Resolution: max. frequency corresponds to 0-10V Range: 0 ~ 10V/0 ~ 20mA Function: Pr.03-18 Switch: AFM switch, factory setting is 0-10V
ACM	Analog control signal (common)	Common for AVI, ACI, AUI, AFM

*Control signal wiring size: 18 AWG (0.75 mm²) with shielded wire.

Analog input terminals (AVI, ACI, AUI, ACM)

- Analog input signals are easily affected by external noise. Use shielded wiring and keep it as short as possible (<20m) with proper grounding. If the noise is inductive, connecting the shield to terminal ACM can bring improvement.
- If the analog input signals are affected by noise from the AC motor drive, please connect a capacitor and ferrite core as indicated in the following diagrams:

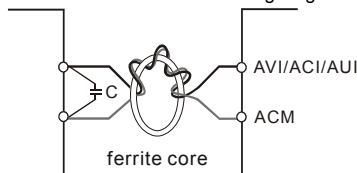

wind each wires 3 times or more around the core

Digital inputs (FWD, REV, MI1~MI6, DCM)

- When using contacts or switches to control the digital inputs, please use high quality components to avoid contact bounce.

Digital outputs (MO1, MO2, MCM)

- Make sure to connect the digital outputs to the right polarity, see wiring diagrams.
- When connecting a relay to the digital outputs, connect a surge absorber or fly-back diode across the coil and check the polarity.

General

- Keep control wiring as far as possible from the power wiring and in separate conduits to avoid interference. If necessary let them cross only at 90° angle.
- The AC motor drive control wiring should be properly installed and not touch any live power wiring or terminals.

NOTE

- If a filter is required for reducing EMI (Electro Magnetic Interference), install it as close as possible to AC drive. EMI can also be reduced by lowering the Carrier Frequency.
- When using a GFCI (Ground Fault Circuit Interrupter), select a current sensor with sensitivity of 200mA, and not less than 0.1-second detection time to avoid nuisance tripping.



DANGER!

Damaged insulation of wiring may cause personal injury or damage to circuits/equipment if it comes in contact with high voltage.

The specification for the control terminals

The Position of the Control Terminals

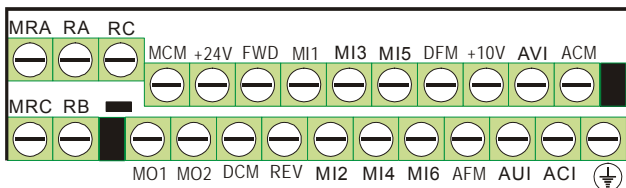

Frame	Torque	Wire
B, C, D, E, E1	8 kgf-cm (6.9 in-lbf)	22-14 AWG (0.3-2.1mm ²)

NOTE

Frame B: VFD007V23A/43A-2, VFD015V23A/43A-2, VFD022V23A/43A-2, VFD037V23A/43A-2;

Frame C: VFD055V23A/43A-2, VFD075V23A/43A-2, VFD110V43B-2,

Frame D: VFD110V23A/43A-2, VFD150V23A/43A-2, VFD185V23A/43A-2, VFD220V23A/43A-2

Frame E: VFD300V43A-2, VFD370V43A-2, VFD450V43A-2

Frame E1: VFD300V23A-2, VFD370V23A-2, VFD550V43C-2, VFD750V43C-2







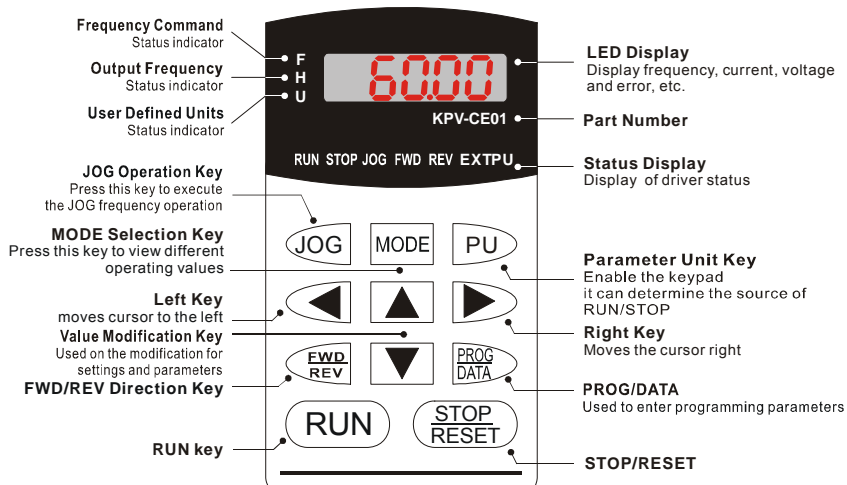

Chapter 3 Digital Keypad Operation and Start Up

3.1 Digital Keypad KPV-CE01

3.1.1 Description of the Digital Keypad KPV-CE01



Display Message	Descriptions
	Displays the AC drive Master Frequency.
	Displays the actual output frequency present at terminals U/T1, V/T2, and W/T3.
	User defined unit (where $U = F \times Pr.00-05$)
	Displays the output current present at terminals U/T1, V/T2, and W/T3.
	The counter value (C).

Display Message	Descriptions
	Displays the selected parameter.
	Displays the actual stored value of the selected parameter.
	External Fault.
	Display "End" for approximately 1 second if input has been accepted by pressing  key. After a parameter value has been set, the new value is automatically stored in memory. To modify an entry, use the  ,  and  keys.
	Display "Err", if the input is invalid.

3.1.2 How to Operate the Digital Keypad KPV-CE01

Selection mode

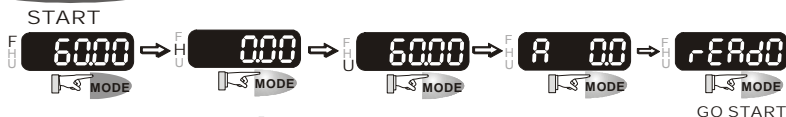

NOTE: In the selection mode, press **PROG DATA** to set the parameters.

To set parameters

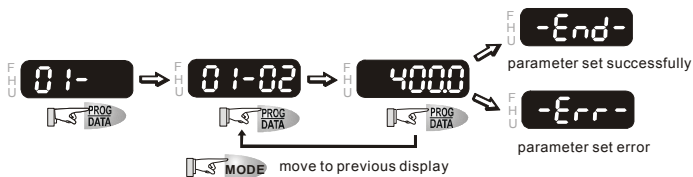

NOTE: In the parameter setting mode, you can press **MODE** to return to the selection mode.

To shift cursor



To modify data



To switch display mode

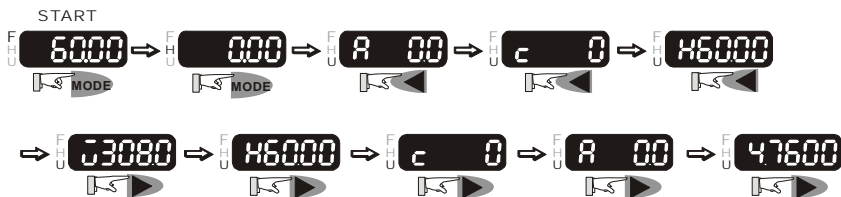

To copy parameters 1

Copy parameters from the AC Motor Drive to the KPV-CE01

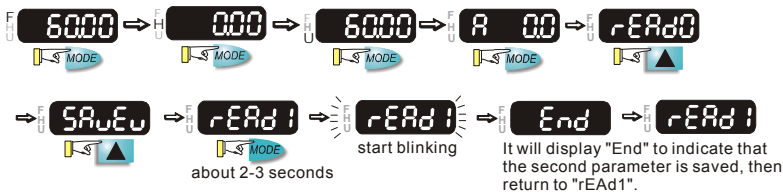
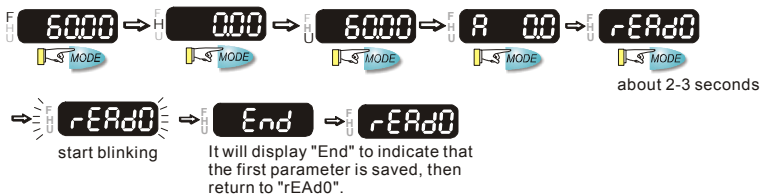

To copy parameters 2

Copy parameters from the KPV-CE01 to the AC Motor Drive

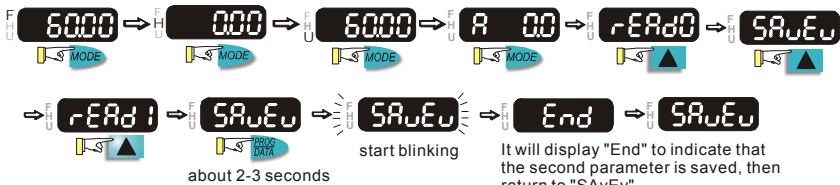
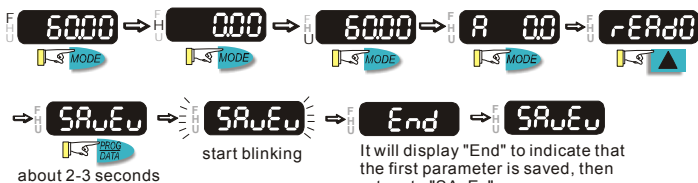

3.1.3 Dimension of the Digital Keypad

Unit: mm [inch]

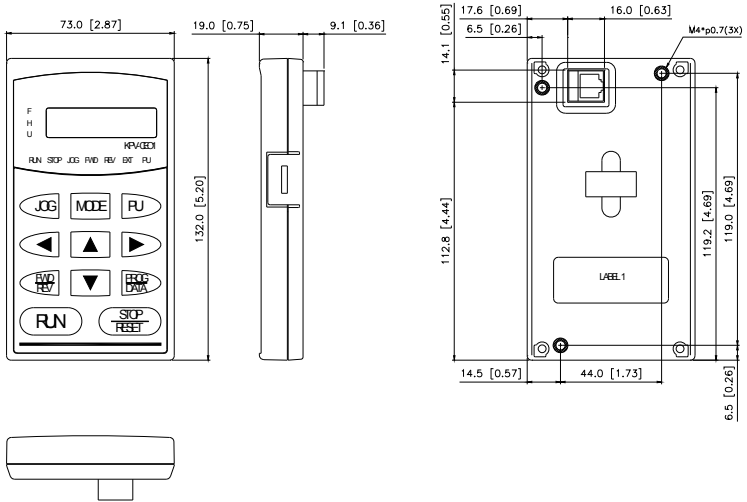

3.1.4 Reference Table for the LCD Display of the Digital Keypad

Digital	0	1	2	3	4	5	6	7	8	9
LCD	0	1	2	3	4	5	6	7	8	9







English alphabet	A	b	Cc	d	E	F	G	Hh	I	Jj
LCD	A	b	Cc	d	E	F	G	Hh	I	Jj

English alphabet	K	L	n	Oo	P	q	r	S	Tt	U
LCD	K	L	n	Oo	P	q	r	S	Tt	U

English alphabet	v	Y	Z							
LCD	v	Y	Z							

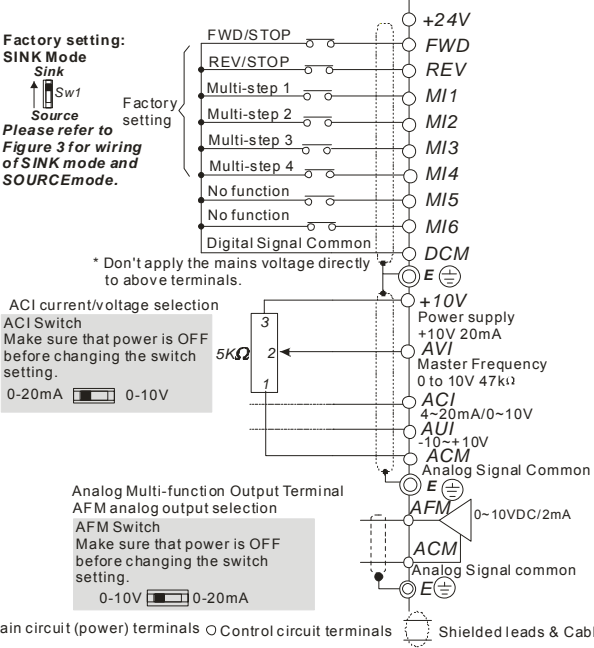
3.1.5 Operation Method

Refer to 3.1.2 How to operate the digital keypad KPV-CE01 and chapter 4 parameters for setting. Please choose a suitable method depending on application and operation rule. The operation is usually used as shown in the following table.

Operation Method	Frequency Source	Operation Command Source
KPV-CE01 keypad		
Operate from external signal	 <p>Factory setting: SINK Mode Sink Sw1 Source Please refer to Figure 3 for wiring of SINK mode and SOURCE mode.</p> <p>Factory setting</p> <p>* Don't apply the mains voltage directly to above terminals.</p> <p>ACI current/voltage selection ACI Switch Make sure that power is OFF before changing the switch setting. 0-20mA  0-10V</p> <p>Analog Multi-function Output Terminal AFM analog output selection AFM Switch Make sure that power is OFF before changing the switch setting. 0-10V  0-20mA</p> <p>Legend: ● Main circuit (power) terminals ○ Control circuit terminals  Shielded leads & Cable</p>	
Operate from communication	Please refer to the communication address 2000H and 2119H settings in the communication address definition.	

3.2 Tuning Operations

3.2.1 Flow Chart

Take motor 1 as example

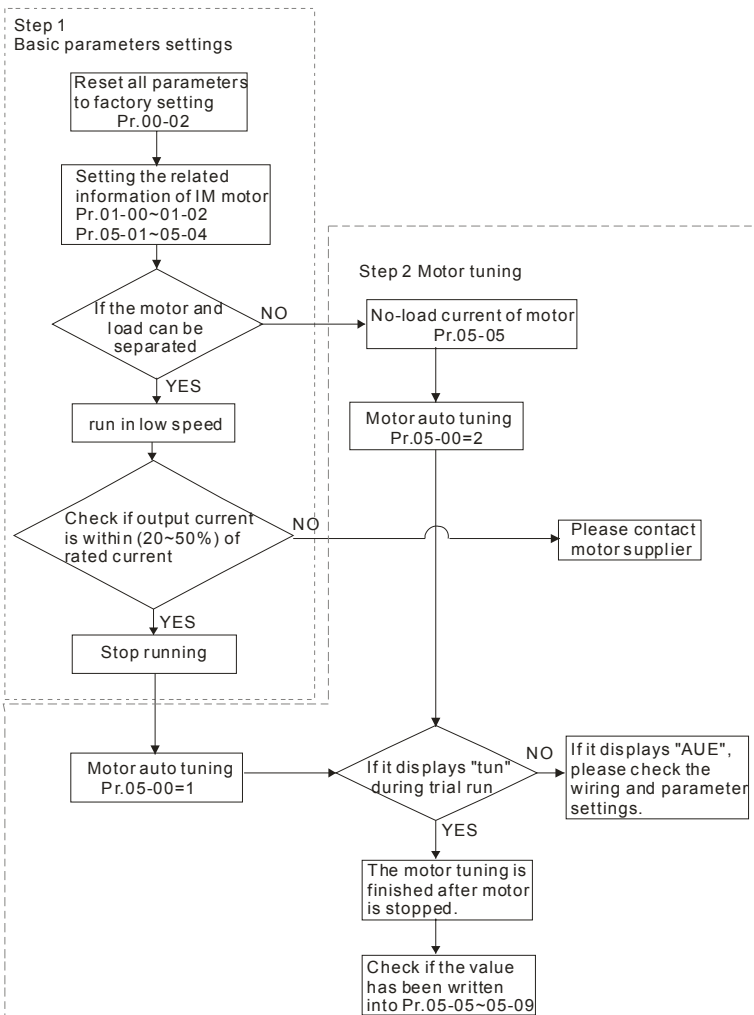

Step 3 Trial run for FOCPG feedback control

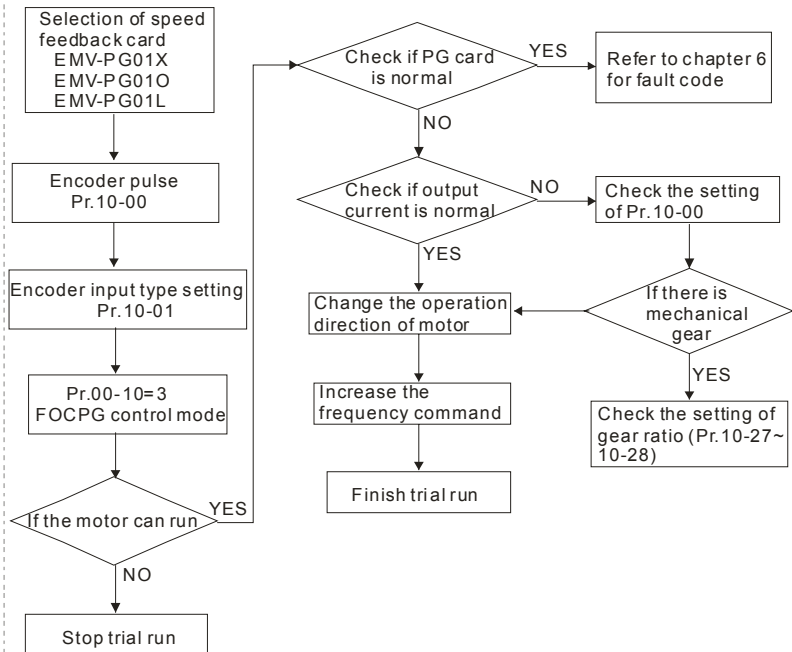

Step 4 Inertia estimation

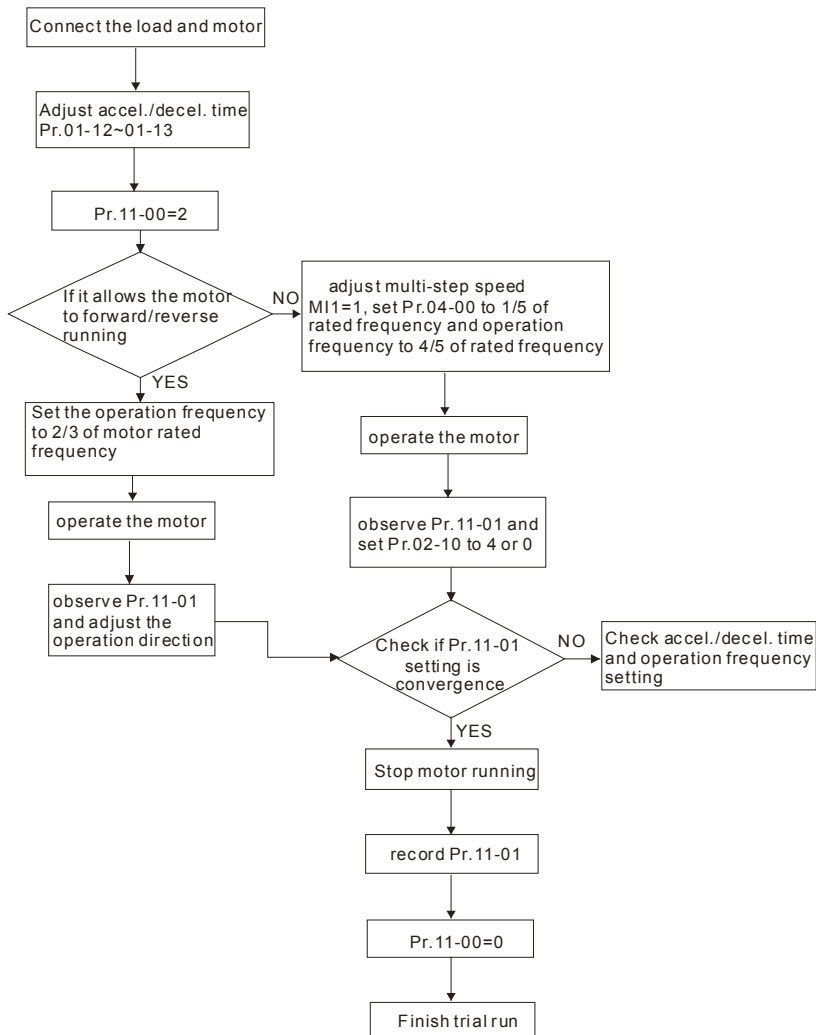

3.2.2 Explanations for the Tuning Steps

3.3.2.1 Step 1

Basic parameters settings for the motor

- Make sure that Pr.00-00 (identity code of the AC motor drive) corresponds with the nameplate indicated on the AC motor drive.
- Make sure that all parameters are reset to factory setting (Pr.00-02 is set to 9 or 10).

Pr.00-02 Parameter Reset	0: No function 1: Read only 2: Enable group 11 parameters setting 8: Keypad lock 9: All parameters are reset to factory settings (50Hz, 220V/380V) 10: All parameters are reset to factory settings (60Hz, 220V/440V)
-----------------------------	--

- Enter the related information of the motor into Pr.01-00~01-02 and Pr.05-01~05-04

Pr.01-00 Max. Output Frequency	50.00 ~ 600.00Hz
-----------------------------------	------------------

Pr.01-01 1st Output Frequency Setting 1	0.00~600.00Hz
--	---------------

Pr.01-02 1st Output Voltage Setting 1	230V: 0.1V~255.0V 460V: 0.1V~510.0V
--	--

Pr.05-01 Full-load Current of Motor 1 (A)	40~120% of drive's rated current
--	----------------------------------

NOTE: This value should be set according to the rated frequency of the motor as indicated on the motor nameplate. The factory setting is 90% of the rated current.

Pr.05-02 Rated Power of Motor 1 (kW)	0~655.35
---	----------

 **NOTE: It is used to set rated power of the motor 1. The factory setting is the power of the drive.**

Pr.05-03 Rated Speed of Motor 1 (rpm)	0~65535
---	---------

 **NOTE:** It is used to set the rated speed of the motor and needs to set according to the value indicated on the motor nameplate.

Pr.05-04 Number of Motor Poles 1	2~20
--	------

NOTE: it is used to set the number of motor poles (must be an even number).

- Check if the motor and load can be separated. If yes, please set by the following steps. If not, please jump to step 2 for static test of the motor auto tuning.
- If the above steps are normal, please trial run in low speed and check if the motor runs steadily without abnormal noise and vibration. If yes, please stop running and check if the wiring is correct or contact the motor supplier.
- After ensure that the output current displayed on the digital keypad is within 20~50% of the motor rated current when trial run in low speed, please go to step 2. If the output current is out of the range, please check the motor wiring, parameter settings or contact the motor supplier.

3.3.2.2 Step 2

Motor tuning

- Make sure that Pr.00-00 (identity code of the AC motor drive) corresponds to the nameplate of the AC motor drive.
- Check if the motor and load can be disconnected.
If yes: set Pr.05-00 to 1 (rolling test)
If not: it needs to input value into Pr.05-05 and set Pr.05-00 to 2 (static test)
- Motor auto tuning

Pr.05-00 Motor Auto Tuning	0: No function 1: Rolling test 2: Static Test 3: Reserved
-------------------------------	--

- It will display  on the digital keypad until the tuning is finished. Then the motor will stop automatically and save the value into Pr.05-06~Pr.05-09. If it displays



, please check if the wiring and parameters settings are correct.

3.3.2.3 Step 3

Trial run for FOC PG feedback control

■ **Selection for speed feedback card**

Please refer to Appendix B PG card for selection. Delta provides 3 PG cards, including EMV-PG01X, EMV-PG01O and EMV-PG01L, for your selection.

■ **Encoder pulse**

Pr.10-00 Encoder Pulse	1~20000
---------------------------	---------

■ **Selection for encoder input type**





Pr.10-01 Encoder Input Type Setting	0: Disable 1: Phase A leads in a forward run command and phase B leads in a reverse run command 2: Phase B leads in a forward run command and phase A leads in a reverse run command 3: Phase A is a pulse input and phase B is a direction input. (low input=reverse direction, high input=forward direction) 4: Phase A is a pulse input and phase B is a direction input. (low input=forward direction, high input=reverse direction) 5: Single-phase input
---	---

■ **Set it to FOC PG mode**

Pr.00-10 Control Method	0: V/f Control 1: V/f Control + Encoder (VFPG) 2: Sensorless vector control (SVC) 3: FOC vector control + Encoder (FOCPG) 4: Torque control + Encoder (TQCPG)
----------------------------	---

■ **Check if the PG feedback card is normal**

1. check if the actual output frequency reaches the frequency command
2. When the PG feedback card is abnormal, the fault code.

	Check if Pr.10-01 is set to 0
	Check if the wiring of the feedback card is correct
	Check if the wiring of the feedback card, PI gain parameter is correct or adjust decel./accel. time
	Check if the wiring of the feedback card, PI gain parameter is correct or adjust decel./accel. time

■ **After the fault is cleared, please trial run again.**

■ **Check if the output current is normal**

When changing frequency command, check if the output current is increased or decreased abnormally. If it is abnormal, please check if Pr.10-00 and Pr.10-27~Pr.10-28 are correct.

■ **Changing the rotation direction of the motor**

Adjust the rotation direction of the motor to ensure that it can run in all the rotation directions.

■ **Increase the frequency command**

Check if the output current/frequency and motor actual speed(it can set Pr.00-04=7 during operation) is normal in different commands.

■ **Finish trial run**

If the results of trial run are normal, the trial run in FOC PG mode is completed.

3.3.2.4 Step 4

Inertia estimate

- Check if the load and motor are connected correctly
- Adjust accel./decel. time

The setting of accel./decel. time(Pr.01-12~Pr.01-13) can be lessened when the current/voltage is within specification (no fault code(over current/voltage) occurs).

Pr.01-12 Accel Time 1	0.00~600.00 sec/0.00~6000.0 sec
--------------------------	---------------------------------

Pr.01-13 Decel Time 1	0.00~600.00 sec/0.00~6000.0 sec
--------------------------	---------------------------------

NOTE: The accel. time is the time that needs for drive to accelerate from 0.0Hz to max. operation frequency (Pr.1-00). The decel. time is the time that needs for drive to decelerate from max. operation frequency (Pr.01-00) to 0.00Hz.

- Inertia estimate
Setting Pr.11-00=2

Pr.11-00 System Control	bit 0: Auto tuning for ASR and APR bit 1: Inertia estimate (only for FOC PG mode) bit 2: Zero Servo bit 3: Reserved
----------------------------	--

- If it allows the motor to rotate in forward and reverse
<Motor can run in both forward and reverse>
After start-up the motor, observe if Pr.11-01 is convergence. After the speed is stable, change the motor operation direction until Pr.11-01 is convergence.
<Motor can only run in one direction>
Setting multi-function input terminal to M1=1, Pr.04-00 to 1/5 of rated frequency and the operation frequency on the digital keypad to 4/5 of rated frequency.

Pr.04-00 1st Step Speed Frequency	0.00~600.00Hz
---	---------------

- Check if the setting of Pr.11-01 is convergence
When the motor runs stably, setting Pr.02-10 to 4 and check if Pr.11-01 is convergence. After setting Pr.02-10 to 0, check if Pr.11-01 is convergence again. Please repeat above operation until Pr.11-01 is convergence.

Pr.02-10 Digital Input Operation Direction	0 ~ 65535
--	-----------

This page intentionally left blank.

Chapter 4 Parameters

The VFD-VE parameters are divided into 12 groups by property for easy setting. In most applications, the user can finish all parameter settings before start-up without the need for re-adjustment during operation.

The 12 groups are as follows:

- Group 0: System Parameters
- Group 1: Basic Parameters
- Group 2: Digital Input/Output Parameters
- Group 3: Analog Input/Output Parameters
- Group 4: Multi-Step Speed Parameters
- Group 5: Motor Parameters
- Group 6: Protection Parameters
- Group 7: Special Parameters
- Group 8: High-function PID Parameters
- Group 9: Communication Parameters
- Group 10: Speed Feedback Control Parameters
- Group 11: Advanced Parameters

4.1 Summary of Parameter Settings

∕: The parameter can be set during operation.

Group 0 System Parameters

Pr.	Explanation	Settings	Factory Setting	VF	VFPG	SVC	FOCPG	TCQPG
00-00	Identity Code of the AC motor drive	Read-only	0	○	○	○	○	○
00-01	Rated Current Display of the AC motor drive	Read-only	0	○	○	○	○	○
00-02	Parameter Reset	0: No function 1: Read only 2: Enable group 11 parameters setting 8: Keypad lock 9: All parameters are reset to factory settings (50Hz, 220V/380V) 10: All parameters are reset to factory settings (60Hz, 220V/440V)	0	○	○	○	○	○
∕00-03	Start-up Display Selection	0: Display the frequency command value (LED F) 1: Display the actual output frequency (LED H) 2: Multifunction display, see Pr.00-04 (LED U) 3: Display the output current (A)	0	○	○	○	○	○
∕00-04	Content of Multi Function Display	0: Display output current (A) 1: Display counter value (C) 2: Display output frequency (H) 3: Display DC-BUS voltage (V) 4: Display output voltage (E) 5: Output power factor angle (n) 6: Display output power (kW) 7: Display actual motor speed (r) 8: Display estimate output torque in N-m (t) 9: Display PG position (G) 10: Display PID feedback in % (b) 11: Display AVI in % (1.) 12: Display ACI in % (2.) 13: Display AUI in % (3.) 14: Display the temperature of heat sink in °C (T) 15: Display the temperature of IGBT in °C (T) 16: The status of digital input (ON/OFF) (i) 17: The status of digital output (ON/OFF) (o) 18: Multi-step speed (S) 19: The corresponding CPU pin status of digital input (i.) 20: The corresponding CPU pin status of digital output (o.) 21: Number of actual motor revolution (PG1 of PG card) (Z) 22: Pulse input frequency (PG2 of PG card) (4) 23: Pulse input position (PG2 of PG card) (4.) 24: Pulse position control for whole operation (MI=37 and MI=ON) (P.) 25: Display the present reel diameter under the tension control in mm (d) 26: Display the present line speed under the tension control in m/min (L) 27: Display the present tension setting under the tension control in N (T.)	0	○	○	○	○	○
∕00-05	User-Defined Coefficient K	Digit 4: decimal point number (0 to 3) Digit 0-3: 40 to 9999	0	○	○	○	○	○
00-06	Software Version	Read-only	##	○	○	○	○	○
∕00-07	Password Input	1 to 9998 and 10000 to 65535 0 to 2: times of wrong password	0	○	○	○	○	○
∕00-08	Password Set	1 to 9998 and 10000 to 65535 0: No password set or successful input in Pr.00-07 1: Password has been set	0	○	○	○	○	○
∕00-09	Energy Saving Gain	10~1000 %	100%				○	
00-10	Control Method	0: V/f Control 1: V/f Control + Encoder (VFPG) 2: Sensorless vector control (SVC) 3: FOC vector control + Encoder (FOCPG) 4: Torque control + Encoder (TCQPG)	0	○	○	○	○	○

Pr.	Explanation	Settings	Factory Setting	VF	VFPG	SVC	FOCPG	TOCPG
00-11	V/f Curve Selection	0: V/f curve determined by group 01 1: 1.5 power curve 2: Square curve	0	<input type="radio"/>	<input type="radio"/>			
↗00-12	Constant/Variable Torque Selection	0: Constant Torque (150%) 1: Variable Torque (120%)	0	<input type="radio"/>	<input type="radio"/>	<input type="radio"/>	<input type="radio"/>	
↗00-13	Optimal Acceleration/Deceleration Setting	0: Linear accel./decel. 1 1: Auto accel., linear decel. 2: Linear accel., auto decel. 3: Auto accel./decel. (auto calculate the accel./decel. time by actual load) 4: Stall prevention by auto accel./decel. (limited by 01-12 to 01-21)	0	<input type="radio"/>	<input type="radio"/>	<input type="radio"/>	<input type="radio"/>	
00-14	Time Unit for Acceleration/Deceleration and S Curve	0: Unit: 0.01 second 1: Unit: 0.1 second	0	<input type="radio"/>	<input type="radio"/>	<input type="radio"/>	<input type="radio"/>	
00-15	Reserved							
00-16	Reserved							
↗00-17	Carrier Frequency	1~15KHz	10	<input type="radio"/>	<input type="radio"/>	<input type="radio"/>	<input type="radio"/>	<input type="radio"/>
↗00-18	Auto Voltage Regulation (AVR) Function	0: Enable AVR 1: Disable AVR 2: Disable AVR when deceleration stop	0	<input type="radio"/>	<input type="radio"/>	<input type="radio"/>	<input type="radio"/>	<input type="radio"/>
↗00-19	Auto Energy-saving Operation	0: Disable 1: Enable	0	<input type="radio"/>	<input type="radio"/>	<input type="radio"/>	<input type="radio"/>	
↗00-20	Source of the Master Frequency Command	0: Digital keypad (KPV-CE01) 1: RS-485 serial communication 2: External analog input (Pr. 03-00) 3: External UP/DOWN terminal 4: Pulse input without direction command (Pr.10-15 without direction) 5: Pulse input with direction command (Pr.10-15)	0	<input type="radio"/>	<input type="radio"/>	<input type="radio"/>	<input type="radio"/>	
↗00-21	Source of the Operation Command	0: Digital keypad (KPV-CE01) 1: External terminals. Keypad STOP disabled. 2: RS-485 serial communication (RJ-11). Keypad STOP disabled.	0	<input type="radio"/>	<input type="radio"/>	<input type="radio"/>	<input type="radio"/>	<input type="radio"/>
↗00-22	Stop Method	0: Ramp to stop 1: Coast to stop	0	<input type="radio"/>	<input type="radio"/>	<input type="radio"/>	<input type="radio"/>	<input type="radio"/>
↗00-23	Motor Direction Control	0: Enable forward/reverse 1: Disable reverse 2: Disable forward	0	<input type="radio"/>	<input type="radio"/>	<input type="radio"/>	<input type="radio"/>	<input type="radio"/>

Group 1 Basic Parameters

Pr.	Explanation	Settings	Factory Setting	VF	VFPG	SVC	FOCPG	TOCPG
01-00	Maximum Output Frequency	50.00~600.00Hz	60.00/ 50.00	○	○	○	○	○
01-01	1st Output Frequency Setting 1	0.00~600.00Hz	60.00/ 50.00	○	○	○	○	○
01-02	1st Output Voltage Setting 1	230V: 0.1V~255.0V 460V: 0.1V~510.0V	220.0 440.0	○	○	○	○	○
01-03	2nd Output Frequency Setting 1	0.00~600.00Hz	0.50	○	○			
01-04	2nd Output Voltage Setting 1	230V: 0.1V~255.0V 460V: 0.1V~510.0V	5.0 10.0	○	○			
01-05	3rd Output Frequency Setting 1	0.00~600.00Hz	0.50	○	○			
01-06	3rd Output Voltage Setting 1	230V: 0.1V~255.0V 460V: 0.1V~510.0V	5.0 10.0	○	○			
01-07	4th Output Frequency Setting 1	0.00~600.00Hz	0.00	○	○	○	○	
01-08	4th Output Voltage Setting 1	230V: 0.1V~255.0V 460V: 0.1V~510.0V	0.0 0.0	○	○			
01-09	Start Frequency	0.00~600.00Hz	0.50	○	○	○	○	
01-10	Output Frequency Upper Limit	0.00~600.00Hz	600.00	○	○	○	○	
01-11	Output Frequency Lower Limit	0.00~600.00Hz	0.00	○	○	○	○	
01-12	Accel Time 1	0.00~600.00 sec/0.00~6000.0 sec	10.00/ 10.0	○	○	○	○	
01-13	Decel Time 1	0.00~600.00 sec/0.00~6000.0 sec	10.00/ 10.0	○	○	○	○	
01-14	Accel Time 2	0.00~600.00 sec/0.00~6000.0 sec	10.00/ 10.0	○	○	○	○	
01-15	Decel Time 2	0.00~600.00 sec/0.00~6000.0 sec	10.00/ 10.0	○	○	○	○	
01-16	Accel Time 3	0.00~600.00 sec/0.00~6000.0 sec	10.00/ 10.0	○	○	○	○	
01-17	Decel Time 3	0.00~600.00 sec/0.00~6000.0 sec	10.00/ 10.0	○	○	○	○	
01-18	Accel Time 4	0.00~600.00 sec/0.00~6000.0 sec	10.00/ 10.0	○	○	○	○	
01-19	Decel Time 4	0.00~600.00 sec/0.00~6000.0 sec	10.00/ 10.0	○	○	○	○	
01-20	JOG Acceleration Time	0.00~600.00 sec/0.00~6000.0 sec	1.00/ 1.0	○	○	○	○	
01-21	JOG Deceleration Time	0.00~600.00 sec/0.00~6000.0 sec	1.00/ 1.0	○	○	○	○	
01-22	JOG Frequency	0.00~600.00Hz	6.00	○	○	○	○	○
01-23	1st/4th Accel/decel Frequency	0.00~600.00Hz	0.00	○	○	○	○	
01-24	S-curve for Acceleration Departure Time 1	0.00~25.00 sec/0.00~250.0 sec	0.2/0.0	○	○	○	○	
01-25	S-curve for Acceleration Arrival Time 2	0.00~25.00 sec /0.00~250.0 sec	0.2/0.0	○	○	○	○	
01-26	S-curve for Deceleration Departure Time 1	0.00~25.00 sec /0.00~250.0 sec	0.2/0.0	○	○	○	○	
01-27	S-curve for Deceleration Arrival Time 2	0.00~25.00 sec /0.00~250.0 sec	0.2/0.0	○	○	○	○	
01-28	Skip Frequency 1 (upper limit)	0.00~600.00Hz	0.00	○	○	○	○	
01-29	Skip Frequency 1 (lower limit)	0.00~600.00Hz	0.00	○	○	○	○	
01-30	Skip Frequency 2 (upper limit)	0.00~600.00Hz	0.00	○	○	○	○	
01-31	Skip Frequency 2 (lower limit)	0.00~600.00Hz	0.00	○	○	○	○	
01-32	Skip Frequency 3 (upper limit)	0.00~600.00Hz	0.00	○	○	○	○	
01-33	Skip Frequency 3 (lower limit)	0.00~600.00Hz	0.00	○	○	○	○	
01-34	Mode Selection when Frequency < Fmin	0: Output Waiting 1: Zero-speed operation 2: Fmin (4th output frequency setting)	0	○	○	○	○	
01-35	1st Output Frequency Setting 2	0.00~600.00Hz	60.00/ 50.00	○	○	○	○	○
01-36	1st Output Voltage Setting 2	230V: 0.1V~255.0V 460V: 0.1V~510.0V	220.0 440.0	○	○	○	○	○
01-37	2nd Output Frequency Setting 2	0.00~600.00Hz	0.50	○	○			
01-38	2nd Output Voltage Setting 2	230V: 0.1V~255.0V	5.0/	○	○			

Pr.	Explanation	Settings	Factory Setting	VF	VFP	SVC	FOCPG	TOCPG
01-39	3rd Output Frequency Setting 2	460V: 0.1V~510.0V	10.0					
		0.00~600.00Hz	0.50	<input type="radio"/>	<input type="radio"/>			
↗01-40	3rd Output Voltage Setting 2	230V: 0.1V~255.0V 460V: 0.1V~510.0V	5.0/ 10.0	<input type="radio"/>	<input type="radio"/>			
01-41	4th Output Frequency Setting 2	0.00~600.00Hz	0.00	<input type="radio"/>	<input type="radio"/>	<input type="radio"/>	<input type="radio"/>	<input type="radio"/>
↗01-42	4th Output Voltage Setting 2	230V: 0.1V~255.0V 460V: 0.1V~510.0V	0.0/ 0.0	<input type="radio"/>	<input type="radio"/>			

Group 2 Digital Input/Output Parameters

Pr.	Explanation	Settings	Factory Setting	VF	VFPG	SVC	FOCPG	TOCPG
02-00	2-wire/3-wire Operation Control	0: FWD/STOP, REV/STOP 1: FWD/STOP, REV/STOP (Line Start Lockout) 2: RUN/STOP, REV/FWD 3: RUN/STOP, REV/FWD (Line Start Lockout) 4: 3-wire (momentary push button) 5: 3-wire (momentary push button and Line Start Lockout)	0	<input type="checkbox"/>	<input type="checkbox"/>	<input type="checkbox"/>	<input type="checkbox"/>	<input type="checkbox"/>
02-01	Multi-Function Input Command 1 (MI1) (it is Stop terminal for 3-wire operation)	0: no function	1	<input type="checkbox"/>	<input type="checkbox"/>	<input type="checkbox"/>	<input type="checkbox"/>	<input type="checkbox"/>
		1: multi-step speed command 1/multi-step position command 1		<input type="checkbox"/>	<input type="checkbox"/>	<input type="checkbox"/>	<input type="checkbox"/>	
02-02	Multi-Function Input Command 2 (MI2)	2: multi-step speed command 2/ multi-step position command 2	2	<input type="checkbox"/>	<input type="checkbox"/>	<input type="checkbox"/>	<input type="checkbox"/>	
		3: multi-step speed command 3/ multi-step position command 3		<input type="checkbox"/>	<input type="checkbox"/>	<input type="checkbox"/>	<input type="checkbox"/>	
02-03	Multi-Function Input Command 3 (MI3)	4: multi-step speed command 4/ multi-step position command 4	3	<input type="checkbox"/>	<input type="checkbox"/>	<input type="checkbox"/>	<input type="checkbox"/>	<input type="checkbox"/>
		5: Reset		<input type="checkbox"/>	<input type="checkbox"/>	<input type="checkbox"/>	<input type="checkbox"/>	
02-04	Multi-Function Input Command 4 (MI4)	6: JOG command	4	<input type="checkbox"/>	<input type="checkbox"/>	<input type="checkbox"/>	<input type="checkbox"/>	
		7: acceleration/deceleration speed inhibit		<input type="checkbox"/>	<input type="checkbox"/>	<input type="checkbox"/>	<input type="checkbox"/>	
02-05	Multi-Function Input Command 5 (MI5)	8: the 1st, 2nd acceleration/deceleration time selection	0	<input type="checkbox"/>	<input type="checkbox"/>	<input type="checkbox"/>	<input type="checkbox"/>	
		9: the 3rd, 4th acceleration/deceleration time selection		<input type="checkbox"/>	<input type="checkbox"/>	<input type="checkbox"/>	<input type="checkbox"/>	
02-06	Multi-Function Input Command 6 (MI6) (specific terminal for TRG)	10: EF input (Pr.07-36)	0	<input type="checkbox"/>	<input type="checkbox"/>	<input type="checkbox"/>	<input type="checkbox"/>	<input type="checkbox"/>
		11: B.B. input		<input type="checkbox"/>	<input type="checkbox"/>	<input type="checkbox"/>	<input type="checkbox"/>	<input type="checkbox"/>
		12: Output stop		<input type="checkbox"/>	<input type="checkbox"/>	<input type="checkbox"/>	<input type="checkbox"/>	<input type="checkbox"/>
02-23	Multi-Function Input Command 7	13: cancel the setting of the optimal acceleration/deceleration time	0	<input type="checkbox"/>	<input type="checkbox"/>	<input type="checkbox"/>	<input type="checkbox"/>	
02-24	Multi-Function Input Command 8	14: switch between drive settings 1 and 2	0	<input type="checkbox"/>	<input type="checkbox"/>	<input type="checkbox"/>	<input type="checkbox"/>	
02-25	Multi-Function Input Command 9	15: operation speed command form AVI	0	<input type="checkbox"/>	<input type="checkbox"/>	<input type="checkbox"/>	<input type="checkbox"/>	
02-26	Multi-Function Input Command 10	16: operation speed command form ACI	0	<input type="checkbox"/>	<input type="checkbox"/>	<input type="checkbox"/>	<input type="checkbox"/>	
02-27	Multi-Function Input Command 11	17: operation speed command form AUI	0	<input type="checkbox"/>	<input type="checkbox"/>	<input type="checkbox"/>	<input type="checkbox"/>	
02-28	Multi-Function Input Command 12	18: Emergency Stop (Pr.07-36)	0	<input type="checkbox"/>	<input type="checkbox"/>	<input type="checkbox"/>	<input type="checkbox"/>	<input type="checkbox"/>
02-29	Multi-Function Input Command 13	19: Digital Up command	0	<input type="checkbox"/>	<input type="checkbox"/>	<input type="checkbox"/>	<input type="checkbox"/>	
02-30	Multi-Function Input Command 14	20: Digital Down command	0	<input type="checkbox"/>	<input type="checkbox"/>	<input type="checkbox"/>	<input type="checkbox"/>	
		21: PID function disabled		<input type="checkbox"/>	<input type="checkbox"/>	<input type="checkbox"/>	<input type="checkbox"/>	
		22: clear counter		<input type="checkbox"/>	<input type="checkbox"/>	<input type="checkbox"/>	<input type="checkbox"/>	<input type="checkbox"/>
		23: input the counter value (multi-function input command 6)		<input type="checkbox"/>	<input type="checkbox"/>	<input type="checkbox"/>	<input type="checkbox"/>	<input type="checkbox"/>
		24: FWD JOG command		<input type="checkbox"/>	<input type="checkbox"/>	<input type="checkbox"/>	<input type="checkbox"/>	
		25: REV JOG command		<input type="checkbox"/>	<input type="checkbox"/>	<input type="checkbox"/>	<input type="checkbox"/>	
		26: TOCPG/FOCPG mode selection		<input type="checkbox"/>	<input type="checkbox"/>	<input type="checkbox"/>	<input type="checkbox"/>	<input type="checkbox"/>
		27: ASR1/ASR2 selection		<input type="checkbox"/>	<input type="checkbox"/>	<input type="checkbox"/>	<input type="checkbox"/>	
		28: Emergency stop (EF1)		<input type="checkbox"/>	<input type="checkbox"/>	<input type="checkbox"/>	<input type="checkbox"/>	<input type="checkbox"/>
		29: Signal confirmation for Y-connection		<input type="checkbox"/>	<input type="checkbox"/>	<input type="checkbox"/>	<input type="checkbox"/>	<input type="checkbox"/>
		30: Signal confirmation for Δ-connection		<input type="checkbox"/>	<input type="checkbox"/>	<input type="checkbox"/>	<input type="checkbox"/>	<input type="checkbox"/>
		31: High torque bias (by Pr.07-29)		<input type="checkbox"/>	<input type="checkbox"/>	<input type="checkbox"/>	<input type="checkbox"/>	<input type="checkbox"/>
		32: Middle torque bias (by Pr.07-30)		<input type="checkbox"/>	<input type="checkbox"/>	<input type="checkbox"/>	<input type="checkbox"/>	<input type="checkbox"/>
		33: Low torque bias (by Pr.07-31)		<input type="checkbox"/>	<input type="checkbox"/>	<input type="checkbox"/>	<input type="checkbox"/>	<input type="checkbox"/>
		34: Enable multi-step position control		<input type="checkbox"/>	<input type="checkbox"/>	<input type="checkbox"/>	<input type="checkbox"/>	
		35: Enable position control		<input type="checkbox"/>	<input type="checkbox"/>	<input type="checkbox"/>	<input type="checkbox"/>	
		36: Enable multi-step position learning function (valid at stop)		<input type="checkbox"/>	<input type="checkbox"/>	<input type="checkbox"/>	<input type="checkbox"/>	
		37: Enable pulse position input command		<input type="checkbox"/>	<input type="checkbox"/>	<input type="checkbox"/>	<input type="checkbox"/>	
		38: Disable write EEPROM function		<input type="checkbox"/>	<input type="checkbox"/>	<input type="checkbox"/>	<input type="checkbox"/>	<input type="checkbox"/>
		39: Torque command direction		<input type="checkbox"/>	<input type="checkbox"/>	<input type="checkbox"/>	<input type="checkbox"/>	<input type="checkbox"/>
40: Force stop	<input type="checkbox"/>	<input type="checkbox"/>	<input type="checkbox"/>	<input type="checkbox"/>	<input type="checkbox"/>			
41: Serial position clock	<input type="checkbox"/>	<input type="checkbox"/>	<input type="checkbox"/>	<input type="checkbox"/>	<input type="checkbox"/>			
42: Serial position input	<input type="checkbox"/>	<input type="checkbox"/>	<input type="checkbox"/>	<input type="checkbox"/>	<input type="checkbox"/>			

Pr.	Explanation	Settings	Factory Setting	VF	VFPG	SVC	FOCPG	TQCPG
		43: Analog input resolution selection					○	○
		44: Enable initial reel diameter		○	○	○	○	○
		45: Reset initial reel diameter 1		○	○	○	○	○
		46: Reset initial reel diameter 2		○	○	○	○	○
		47: Reset PID control integration of tension		○	○	○	○	○
		48: Mechanical gear ratio switch		○	○	○	○	○
		49: Enable Drive		○	○	○	○	○
		50: Reserved						
↗02-07	UP/DOWN Key Mode	0: up/down by the accel/decel time 1: up/down constant speed (Pr.02-08)	0	○	○	○	○	○
↗02-08	The Acceleration/Deceleration Speed of the UP/DOWN Key with Constant Speed	0.01 ~ 1.00Hz/ms	0.01	○	○	○	○	○
↗02-09	Digital Input Response Time	0.001 ~ 30.000 sec	0.005	○	○	○	○	○
↗02-10	Digital Input Operation Direction	0 ~ 65535	0	○	○	○	○	○
↗02-11	Multi-function Output 1 RA, RB, RC(Relay1)	0: No function 1: Operation indication	11	○	○	○	○	○
↗02-12	Multi-function Output 2 MRA, MRC (Relay2)	2: Operation speed attained 3: Desired frequency attained 1 (Pr.02-19)	1	○	○	○	○	○
↗02-13	Multi-function Output 3 (MO1)	4: Desired frequency attained 2 (Pr.02-21) 5: Zero speed (frequency command) 6: Zero speed with stop (frequency command) 7: Over torque (OT1) (Pr.06-06-06-08) 8: Over torque (OT2) (Pr.06-09-06-11)	0	○	○	○	○	○
↗02-14	Multi-function Output 4 (MO2)	9: Drive ready 10: User-defined Low-voltage Detection 11: Malfunction indication	0	○	○	○	○	○
↗02-35	Multi-function Output 5 (MO3)	12: Mechanical brake release (Pr.02-31) 13: Overheat 14: Software brake signal indication		○	○	○	○	○
↗02-36	Multi-function Output 6 (MO4)	15: PID feedback error 16: Slip error (oSL) 17: Terminal count value attained (Pr.02-16)		○	○	○	○	○
↗02-37	Multi-function Output 7 (MO5)	18: Preliminary count value attained (Pr.02-17) 19: Baseblock (B.B.) Indication 20: Warning output		○	○	○	○	○
↗02-38	Multi-function Output 8 (MO6)	21: Over voltage warning 22: Over-current stall prevention warning 23: Over-voltage stall prevention warning		○	○	○	○	○
↗02-39	Multi-function Output 9 (MO7)	24: Operation mode indication 25: Forward command 26: Reverse command		○	○	○	○	○
↗02-40	Multi-function Output 10 (MO8)	27: Output when current >= Pr.02-32 28: Output when current < Pr.02-32 29: Output when frequency >= Pr.02-33 30: Output when frequency < Pr.02-33		○	○	○	○	○
↗02-41	Multi-function Output 11 (MO9)	31: Y-connection for the motor coil 32: Δ connection for the motor coil		○	○	○	○	○
↗02-42	Multi-function Output 12 (MOA)	33: Zero speed (actual output frequency) 34: Zero speed with Stop (actual output frequency) 35: Error output selection 1 (Pr.06-23) 36: Error output selection 2 (Pr.06-24) 37: Error output selection 3 (Pr.06-25) 38: Error output selection 4 (Pr.06-26) 39: Position attained (Pr.10-19) 40: Speed attained (including zero speed) 41: Multi-position attained 42: Crane function		○	○	○	○	○

Chapter 4 Parameters | VFD-VE

Pr.	Explanation	Settings	Factory Setting	VF	VFPG	SVC	FOCPG	TQCPG
		43: Motor zero-speed output (Pr.02-43)			<input type="radio"/>		<input type="radio"/>	
		44: Max. reel diameter attained		<input type="radio"/>	<input type="radio"/>	<input type="radio"/>	<input type="radio"/>	<input type="radio"/>
		45: Empty reel diameter attained		<input type="radio"/>	<input type="radio"/>	<input type="radio"/>	<input type="radio"/>	<input type="radio"/>
		46: Broken belt detection		<input type="radio"/>	<input type="radio"/>	<input type="radio"/>	<input type="radio"/>	<input type="radio"/>
		47: Break release at stop		<input type="radio"/>	<input type="radio"/>	<input type="radio"/>	<input type="radio"/>	<input type="radio"/>
		48: Error PID feedback of tension		<input type="radio"/>	<input type="radio"/>	<input type="radio"/>	<input type="radio"/>	<input type="radio"/>
		49: Reserved						
		50: Reserved						
↗02-15	Multi-output Direction	0 ~ 65535	0	<input type="radio"/>	<input type="radio"/>	<input type="radio"/>	<input type="radio"/>	<input type="radio"/>
↗02-16	Terminal Count Value	0 ~ 65535	0	<input type="radio"/>	<input type="radio"/>	<input type="radio"/>	<input type="radio"/>	<input type="radio"/>
↗02-17	Preliminary Counter Value	0 ~ 65535	0	<input type="radio"/>	<input type="radio"/>	<input type="radio"/>	<input type="radio"/>	<input type="radio"/>
↗02-18	Digital Output Gain	1 ~ 40	1	<input type="radio"/>	<input type="radio"/>	<input type="radio"/>	<input type="radio"/>	<input type="radio"/>
↗02-19	Desired Frequency Attained 1	0.00 ~ 600.00Hz	60.00/ 50.00	<input type="radio"/>	<input type="radio"/>	<input type="radio"/>	<input type="radio"/>	
↗02-20	The Width of the Desired Frequency Attained 1	0.00 ~ 600.00Hz	2.00	<input type="radio"/>	<input type="radio"/>	<input type="radio"/>	<input type="radio"/>	
↗02-21	Desired Frequency Attained 2	0.00 ~ 600.00Hz	60.00/ 50.00	<input type="radio"/>	<input type="radio"/>	<input type="radio"/>	<input type="radio"/>	
↗02-22	The Width of the Desired Frequency Attained 2	0.00 ~ 600.00Hz	2.00	<input type="radio"/>	<input type="radio"/>	<input type="radio"/>	<input type="radio"/>	
02-31	Brake Delay Time	0.000~65.000 Sec	0.000	<input type="radio"/>	<input type="radio"/>	<input type="radio"/>	<input type="radio"/>	<input type="radio"/>
↗02-32	Output Current Level Setting for External Terminals	0~100%	0	<input type="radio"/>	<input type="radio"/>	<input type="radio"/>	<input type="radio"/>	<input type="radio"/>
↗02-33	Output Boundary for External Terminals	0.00~+60.00Hz (it is motor speed when using PG)	0.00	<input type="radio"/>	<input type="radio"/>	<input type="radio"/>	<input type="radio"/>	<input type="radio"/>
↗02-34	External Operation Control Selection after Reset	0: Disable 1: Drive runs if run command exists after reset	0	<input type="radio"/>	<input type="radio"/>	<input type="radio"/>	<input type="radio"/>	<input type="radio"/>
↗02-43	Zero-speed Level of Motor	0~65535 rpm	0		<input type="radio"/>		<input type="radio"/>	<input type="radio"/>

Group 3 Analog Input/Output Parameters

Pr.	Explanation	Settings	Factory Setting	VF	VFPG	SVC	FOCPG	TOCPG
↗03-00	Analog Input 1 (AVI)	0: No function	1	○	○	○	○	○
↗03-01	Analog Input 2 (ACI)	1: Frequency command (torque limit under TQR control mode)	0	○	○	○	○	○
↗03-02	Analog Input 3 (AUI)	2: torque command (torque limit under speed mode)	0					○
		3: Torque compensation command		○	○	○	○	○
		4: PID target value (refer to group 8)		○	○	○	○	
		5: PID feedback signal (refer to group 8)		○	○	○	○	
		6: P.T.C. thermistor input value		○	○	○	○	○
		7: Positive torque limit						○
		8: Negative torque limit						○
		9: Regenerative torque limit						○
		10: Positive/negative torque limit						○
		11: PID feedback signal of tension		○	○	○	○	○
		12: Line speed		○	○	○	○	○
		13: Reel diameter		○	○	○	○	○
		14: PID target value of tension (tension closed-loop)		○	○	○	○	○
		15: Tension setting (tension open-loop)						○
		16: Zero-speed tension						○
		17: Tension taper						○
		↗03-03		Analog Input Bias 1 (AVI)	-100.0~100.0%	0	○	○
↗03-04	Analog Input Bias 2 (ACI)	-100.0~100.0%	0	○	○	○	○	
↗03-05	Analog Input Bias 3 (AUI)	-100.0~100.0%	0	○	○	○	○	
↗03-06	Positive/negative Bias Mode (AVI)	0: Zero bias 1: Lower than bias=bias	0	○	○	○	○	
↗03-07	Positive/negative Bias Mode (ACI)	2: Greater than bias=bias 3: The absolute value of the bias voltage while serving as the center	0	○	○	○	○	
↗03-08	Positive/negative Bias Mode (AUI)	4: Serve bias as the center	0	○	○	○	○	
↗03-09	Analog Input Gain 1 (AVI)	-500.0~500.0%	100.0	○	○	○	○	
↗03-10	Analog Input Gain 2 (ACI)	-500.0~500.0%	100.0	○	○	○	○	
↗03-11	Analog Input Gain 3 (AUI)	-500.0~500.0%	100.0	○	○	○	○	
↗03-12	ACI/AVI2 Selection	0: ACI 1: AVI 2	0	○	○	○	○	
↗03-13	Analog Input Delay Time (AVI)	0.00~2.00 sec	0.01	○	○	○	○	
↗03-14	Analog Input Delay Time (ACI)	0.00~2.00 sec	0.01	○	○	○	○	
↗03-15	Analog Input Delay Time (AUI)	0.00~2.00 sec	0.01	○	○	○	○	
↗03-16	Addition Function of the Analog Input	0: Disable (AVI, ACI, AUI) 1: Enable		○	○	○	○	
↗03-17	Loss of the ACI Signal	0: Disable 1: Continue operation at the last frequency 2: Decelerate to stop 3: Stop immediately and display E.F.	0	○	○	○	○	
↗03-18	Analog Output 1	0: Output frequency (Hz)	0	○	○	○	○	○
		1: Frequency command (Hz)		○	○	○	○	○
↗03-21	Analog Output 2	2: Motor speed (Hz)		○	○	○	○	○
		3: Output current (rms)		○	○	○	○	○
↗03-24	Analog Output 3	4: Output voltage		○	○	○	○	○
		5: DC Bus Voltage		○	○	○	○	○
		6: Power factor		○	○	○	○	○
		7: Power		○	○	○	○	○
		8: Output torque		○	○	○	○	○

Pr.	Explanation	Settings	Factory Setting	VF	VFPG	SVC	FOCPG	TOCPG
		9: AVI		<input type="checkbox"/>	<input type="checkbox"/>	<input type="checkbox"/>	<input type="checkbox"/>	<input type="checkbox"/>
		10: ACI		<input type="checkbox"/>	<input type="checkbox"/>	<input type="checkbox"/>	<input type="checkbox"/>	<input type="checkbox"/>
		11: AUI		<input type="checkbox"/>	<input type="checkbox"/>	<input type="checkbox"/>	<input type="checkbox"/>	<input type="checkbox"/>
		12: q-axis current		<input type="checkbox"/>	<input type="checkbox"/>	<input type="checkbox"/>	<input type="checkbox"/>	<input type="checkbox"/>
		13: q-axis feedback value		<input type="checkbox"/>	<input type="checkbox"/>	<input type="checkbox"/>	<input type="checkbox"/>	<input type="checkbox"/>
		14: d-axis current		<input type="checkbox"/>	<input type="checkbox"/>	<input type="checkbox"/>	<input type="checkbox"/>	<input type="checkbox"/>
		15: d-axis feedback value		<input type="checkbox"/>	<input type="checkbox"/>	<input type="checkbox"/>	<input type="checkbox"/>	<input type="checkbox"/>
		16: q-axis voltage		<input type="checkbox"/>	<input type="checkbox"/>	<input type="checkbox"/>	<input type="checkbox"/>	<input type="checkbox"/>
		17: d-axis voltage		<input type="checkbox"/>	<input type="checkbox"/>	<input type="checkbox"/>	<input type="checkbox"/>	<input type="checkbox"/>
		18: Torque command		<input type="checkbox"/>	<input type="checkbox"/>	<input type="checkbox"/>	<input type="checkbox"/>	<input type="checkbox"/>
		19: Pulse frequency command		<input type="checkbox"/>	<input type="checkbox"/>	<input type="checkbox"/>	<input type="checkbox"/>	<input type="checkbox"/>
↗03-19	Gain for Analog Output 1	0-200.0%	100.0	<input type="checkbox"/>	<input type="checkbox"/>	<input type="checkbox"/>	<input type="checkbox"/>	<input type="checkbox"/>
↗03-20	Analog Output 1 Value in REV Direction	0: Absolute value in REV direction 1: Output 0V in REV direction 2: Enable output voltage in REV direction	0	<input type="checkbox"/>	<input type="checkbox"/>	<input type="checkbox"/>	<input type="checkbox"/>	<input type="checkbox"/>
↗03-22	Gain for Analog Output 2	0-200.0%	100.0	<input type="checkbox"/>	<input type="checkbox"/>	<input type="checkbox"/>	<input type="checkbox"/>	<input type="checkbox"/>
↗03-23	Analog Output 2 Value in REV Direction	0: Absolute value in REV direction 1: Output 0V in REV direction 2: Enable output voltage in REV direction	0	<input type="checkbox"/>	<input type="checkbox"/>	<input type="checkbox"/>	<input type="checkbox"/>	<input type="checkbox"/>
↗03-25	Gain for Analog Output 3	0-200.0%	100.0	<input type="checkbox"/>	<input type="checkbox"/>	<input type="checkbox"/>	<input type="checkbox"/>	<input type="checkbox"/>
↗03-26	Analog Output 3 Value in REV Direction	0: Absolute value in REV direction 1: Output 0V in REV direction 2: Enable output voltage in REV direction	0	<input type="checkbox"/>	<input type="checkbox"/>	<input type="checkbox"/>	<input type="checkbox"/>	<input type="checkbox"/>

Group 4 Multi-Step Speed Parameters

Pr.	Explanation	Settings	Factory Setting	VF	VFPG	SVC	FOCPG	TOCPG
↗04-00	1st Step Speed Frequency	0.00~600.00Hz	0.00	<input type="radio"/>	<input type="radio"/>	<input type="radio"/>	<input type="radio"/>	
↗04-01	2nd Step Speed Frequency	0.00~600.00Hz	0.00	<input type="radio"/>	<input type="radio"/>	<input type="radio"/>	<input type="radio"/>	
↗04-02	3rd Step Speed Frequency	0.00~600.00Hz	0.00	<input type="radio"/>	<input type="radio"/>	<input type="radio"/>	<input type="radio"/>	
↗04-03	4th Step Speed Frequency	0.00~600.00Hz	0.00	<input type="radio"/>	<input type="radio"/>	<input type="radio"/>	<input type="radio"/>	
↗04-04	5th Step Speed Frequency	0.00~600.00Hz	0.00	<input type="radio"/>	<input type="radio"/>	<input type="radio"/>	<input type="radio"/>	
↗04-05	6th Step Speed Frequency	0.00~600.00Hz	0.00	<input type="radio"/>	<input type="radio"/>	<input type="radio"/>	<input type="radio"/>	
↗04-06	7th Step Speed Frequency	0.00~600.00Hz	0.00	<input type="radio"/>	<input type="radio"/>	<input type="radio"/>	<input type="radio"/>	
↗04-07	8th Step Speed Frequency	0.00~600.00Hz	0.00	<input type="radio"/>	<input type="radio"/>	<input type="radio"/>	<input type="radio"/>	
↗04-08	9th Step Speed Frequency	0.00~600.00Hz	0.00	<input type="radio"/>	<input type="radio"/>	<input type="radio"/>	<input type="radio"/>	
↗04-09	10th Step Speed Frequency	0.00~600.00Hz	0.00	<input type="radio"/>	<input type="radio"/>	<input type="radio"/>	<input type="radio"/>	
↗04-10	11th Step Speed Frequency	0.00~600.00Hz	0.00	<input type="radio"/>	<input type="radio"/>	<input type="radio"/>	<input type="radio"/>	
↗04-11	12th Step Speed Frequency	0.00~600.00Hz	0.00	<input type="radio"/>	<input type="radio"/>	<input type="radio"/>	<input type="radio"/>	
↗04-12	13th Step Speed Frequency	0.00~600.00Hz	0.00	<input type="radio"/>	<input type="radio"/>	<input type="radio"/>	<input type="radio"/>	
↗04-13	14th Step Speed Frequency	0.00~600.00Hz	0.00	<input type="radio"/>	<input type="radio"/>	<input type="radio"/>	<input type="radio"/>	
↗04-14	15th Step Speed Frequency	0.00~600.00Hz	0.00	<input type="radio"/>	<input type="radio"/>	<input type="radio"/>	<input type="radio"/>	
↗04-15	Multi-position 1	0~65535	0		<input type="radio"/>		<input type="radio"/>	
↗04-16	Multi-position 2	0~65535	0		<input type="radio"/>		<input type="radio"/>	
↗04-17	Multi-position 3	0~65535	0		<input type="radio"/>		<input type="radio"/>	
↗04-18	Multi-position 4	0~65535	0		<input type="radio"/>		<input type="radio"/>	
↗04-19	Multi-position 5	0~65535	0		<input type="radio"/>		<input type="radio"/>	
↗04-20	Multi-position 6	0~65535	0		<input type="radio"/>		<input type="radio"/>	
↗04-21	Multi-position 7	0~65535	0		<input type="radio"/>		<input type="radio"/>	
↗04-22	Multi-position 8	0~65535	0		<input type="radio"/>		<input type="radio"/>	
↗04-23	Multi-position 9	0~65535	0		<input type="radio"/>		<input type="radio"/>	
↗04-24	Multi-position 10	0~65535	0		<input type="radio"/>		<input type="radio"/>	
↗04-25	Multi-position 11	0~65535	0		<input type="radio"/>		<input type="radio"/>	
↗04-26	Multi-position 12	0~65535	0		<input type="radio"/>		<input type="radio"/>	
↗04-27	Multi-position 13	0~65535	0		<input type="radio"/>		<input type="radio"/>	
↗04-28	Multi-position 14	0~65535	0		<input type="radio"/>		<input type="radio"/>	
↗04-29	Multi-position 15	0~65535	0		<input type="radio"/>		<input type="radio"/>	

Group 5 Motor Parameters

Pr.	Explanation	Settings	Factory Setting	VF	VFPG	SVC	FOCPG	TOCPG
05-00	Motor Auto Tuning	0: No function 1: Rolling test 2: Static Test 3: Reserved	0	<input type="radio"/>				
05-01	Full-load Current of Motor 1 (A)	40-120% of drive's rated current	###	<input type="radio"/>	<input type="radio"/>	<input type="radio"/>	<input type="radio"/>	<input type="radio"/>
↗05-02	Rated power of Motor 1 (kW)	0-655.35	###			<input type="radio"/>	<input type="radio"/>	<input type="radio"/>
↗05-03	Rated speed of Motor 1 (rpm)	0-65535 1710 (60Hz, 4 poles), 1410 (50Hz, 4 poles)	1710		<input type="radio"/>	<input type="radio"/>	<input type="radio"/>	<input type="radio"/>
05-04	Number of Motor Poles 1	2-20	4	<input type="radio"/>	<input type="radio"/>	<input type="radio"/>	<input type="radio"/>	<input type="radio"/>
05-05	No-load Current of Motor 1 (A)	0-factory setting of Pr.05-01	###		<input type="radio"/>	<input type="radio"/>	<input type="radio"/>	<input type="radio"/>
05-06	Stator Resistance (Rs) of Motor 1	0-65.535Ω	####			<input type="radio"/>	<input type="radio"/>	<input type="radio"/>
05-07	Rotor Resistance (Rr) of Motor 1	0-65.535Ω	####			<input type="radio"/>	<input type="radio"/>	<input type="radio"/>
05-08	Magnetizing Inductance (Lm) of Motor 1	0-6553.5mH	##			<input type="radio"/>	<input type="radio"/>	<input type="radio"/>
05-09	Stator inductance (Lx) of Motor 1	0-6553.5mH	##			<input type="radio"/>	<input type="radio"/>	<input type="radio"/>
05-10	Motor 1/Motor 2 Selection	1: Motor 1 2: Motor 2	1	<input type="radio"/>	<input type="radio"/>	<input type="radio"/>	<input type="radio"/>	<input type="radio"/>
↗05-11	Frequency for Y-connection/ Δ-connection Switch	0.00-600.00Hz	60.00	<input type="radio"/>	<input type="radio"/>	<input type="radio"/>	<input type="radio"/>	
05-12	Y-connection /Δ-connection Switch	0: Disable 1: Enable	0	<input type="radio"/>	<input type="radio"/>	<input type="radio"/>	<input type="radio"/>	
05-13	Full-load Current of Motor 2 (A)	40-120%	###	<input type="radio"/>	<input type="radio"/>	<input type="radio"/>	<input type="radio"/>	<input type="radio"/>
↗05-14	Rated Power of Motor 2 (kW)	0-655.35	###			<input type="radio"/>	<input type="radio"/>	<input type="radio"/>
↗05-15	Rated Speed of Motor 2 (rpm)	0-65535	1710		<input type="radio"/>	<input type="radio"/>	<input type="radio"/>	<input type="radio"/>
05-16	Number of Motor Poles 2	2-20	4	<input type="radio"/>	<input type="radio"/>	<input type="radio"/>	<input type="radio"/>	<input type="radio"/>
05-17	No-load Current of Motor 2 (A)	0-factory setting of Pr.05-01	###		<input type="radio"/>	<input type="radio"/>	<input type="radio"/>	<input type="radio"/>
05-18	Stator Resistance(Rs) of Motor 2	0-65.535Ω	####			<input type="radio"/>	<input type="radio"/>	<input type="radio"/>
05-19	Rotor Resistance(Rr) of Motor 2	0-65.535Ω	####			<input type="radio"/>	<input type="radio"/>	<input type="radio"/>
05-20	Magnetizing Inductance (Lm) of Motor 2	0-6553.5mH	##			<input type="radio"/>	<input type="radio"/>	<input type="radio"/>
05-21	Stator Inductance(Lx) of Motor 2	0-6553.5mH	##			<input type="radio"/>	<input type="radio"/>	<input type="radio"/>
↗05-22	Torque Compensation Time Constant	0.001-10.000sec	0.020	<input type="radio"/>	<input type="radio"/>			
↗05-23	Slip Compensation Time Constant	0.001-10.000sec	0.100		<input type="radio"/>	<input type="radio"/>		
↗05-24	Torque Compensation Gain	0-10	0	<input type="radio"/>	<input type="radio"/>			
↗05-25	Slip Compensation Gain	0.00-10.00	0.00	<input type="radio"/>		<input type="radio"/>		
↗05-26	Slip Deviation Level	0-1000% (0: disable)	0		<input type="radio"/>	<input type="radio"/>	<input type="radio"/>	
↗05-27	Detection Time of Slip Deviation	0.0-10.0 sec	1.0		<input type="radio"/>	<input type="radio"/>	<input type="radio"/>	
↗05-28	Over Slip Treatment	0: Warn and keep operation 1: Warn and ramp to stop 2: Warn and coast to stop	0		<input type="radio"/>	<input type="radio"/>	<input type="radio"/>	
↗05-29	Hunting Gain	0-10000 (0: disable)	2000	<input type="radio"/>	<input type="radio"/>			
↗05-30	Delay Time for Y-connection/Δ-connection	0-60.000 sec	0.200	<input type="radio"/>	<input type="radio"/>	<input type="radio"/>	<input type="radio"/>	
05-31	Accumulative Motor Operation Time (Min.)	00-1439	0	<input type="radio"/>	<input type="radio"/>	<input type="radio"/>	<input type="radio"/>	<input type="radio"/>
05-32	Accumulative Motor Operation Time (day)	00-65535	0	<input type="radio"/>	<input type="radio"/>	<input type="radio"/>	<input type="radio"/>	<input type="radio"/>

Group 6 Protection Parameters

Pr.	Explanation	Settings	Factory Setting	VF	VFPG	SVL	F0CPG	TOCPG
Pr. 06-00	Low Voltage Level	160.0~220.0Vdc	180.0	<input type="radio"/>	<input type="radio"/>	<input type="radio"/>	<input type="radio"/>	<input type="radio"/>
		320.0~440.0Vdc	360.0	<input type="radio"/>	<input type="radio"/>	<input type="radio"/>	<input type="radio"/>	<input type="radio"/>
Pr. 06-01	Over-voltage Stall Prevention	0.0: Disable		<input type="radio"/>	<input type="radio"/>	<input type="radio"/>	<input type="radio"/>	<input type="radio"/>
		350.0~450.0Vdc	380.0	<input type="radio"/>	<input type="radio"/>	<input type="radio"/>	<input type="radio"/>	<input type="radio"/>
		700.0~900.0Vdc	760.0	<input type="radio"/>	<input type="radio"/>	<input type="radio"/>	<input type="radio"/>	<input type="radio"/>
Pr. 06-02	Phase-loss Protection	0: Warn and keep operation 1: Warn and ramp to stop 2: Warn and coast to stop	0	<input type="radio"/>	<input type="radio"/>	<input type="radio"/>	<input type="radio"/>	<input type="radio"/>
Pr. 06-03	Over-current Stall Prevention during Acceleration	00~250% (100%: drive's rated current)	170	<input type="radio"/>	<input type="radio"/>	<input type="radio"/>	<input type="radio"/>	<input type="radio"/>
Pr. 06-04	Over-current Stall Prevention during Operation	00~250% (100%: drive's rated current)	170	<input type="radio"/>	<input type="radio"/>	<input type="radio"/>	<input type="radio"/>	<input type="radio"/>
Pr. 06-05	Accel./Decel. Time Selection of Stall Prevention at constant speed	0: by current accel/decel time 1: by the 1st accel/decel time 2: by the 2nd accel/decel time 3: by the 3rd accel/decel time 4: by the 4th accel/decel time 5: by auto accel/decel time	0	<input type="radio"/>	<input type="radio"/>	<input type="radio"/>	<input type="radio"/>	<input type="radio"/>
Pr. 06-06	Over-torque Detection Selection (OT1)	0: disable 1: over-torque detection during constant speed operation, continue to operate after detection 2: over-torque detection during constant speed operation, stop operation after detection 3: over-torque detection during operation, continue to operate after detection 4: over-torque detection during operation, stop operation after detection	0	<input type="radio"/>	<input type="radio"/>	<input type="radio"/>	<input type="radio"/>	<input type="radio"/>
Pr. 06-07	Over-torque Detection Level (OT1)	10~250%(100%: drive's rated current)	150	<input type="radio"/>	<input type="radio"/>	<input type="radio"/>	<input type="radio"/>	<input type="radio"/>
Pr. 06-08	Over-torque Detection Time (OT1)	0.0~60.0 sec	0.1	<input type="radio"/>	<input type="radio"/>	<input type="radio"/>	<input type="radio"/>	<input type="radio"/>
Pr. 06-09	Over-torque Detection Selection (OT2)	0: disable 1: over-torque detection during constant speed operation, continue to operate after detection 2: over-torque detection during constant speed operation, stop operation after detection 3: over-torque detection during operation, continue to operate after detection 4: over-torque detection during operation, stop operation after detection	0	<input type="radio"/>	<input type="radio"/>	<input type="radio"/>	<input type="radio"/>	<input type="radio"/>
Pr. 06-10	Over-torque Detection Level (OT2)	10~250%(100%: drive's rated current)	150	<input type="radio"/>	<input type="radio"/>	<input type="radio"/>	<input type="radio"/>	<input type="radio"/>
Pr. 06-11	Over-torque Detection Time (OT2)	0.0~60.0 sec	0.1	<input type="radio"/>	<input type="radio"/>	<input type="radio"/>	<input type="radio"/>	<input type="radio"/>
Pr. 06-12	Current Limit	0~250%(100%: drive's rated current)	150	<input type="radio"/>	<input type="radio"/>	<input type="radio"/>	<input type="radio"/>	<input type="radio"/>
Pr. 06-13	Electronic Thermal Relay Selection (Motor 1)	0: Inverter motor 1: Standard motor 2: Disable	2	<input type="radio"/>	<input type="radio"/>	<input type="radio"/>	<input type="radio"/>	<input type="radio"/>
Pr. 06-14	Electronic Thermal Characteristic for Motor 1	30.0~600.0 sec	60.0	<input type="radio"/>	<input type="radio"/>	<input type="radio"/>	<input type="radio"/>	<input type="radio"/>
Pr. 06-15	Heat Sink Over-heat (OH) Warning	0.0~110.0 °C	85.0	<input type="radio"/>	<input type="radio"/>	<input type="radio"/>	<input type="radio"/>	<input type="radio"/>
Pr. 06-16	Stall Prevention Limit Level	0~100% (refer to Pr.06-03, Pr.06-04)	50	<input type="radio"/>	<input type="radio"/>	<input type="radio"/>	<input type="radio"/>	<input type="radio"/>
06-17	Present Fault Record	0: No fault	0	<input type="radio"/>	<input type="radio"/>	<input type="radio"/>	<input type="radio"/>	<input type="radio"/>
		1: Over-current during acceleration (ocA)		<input type="radio"/>	<input type="radio"/>	<input type="radio"/>	<input type="radio"/>	<input type="radio"/>
06-18	Second Most Recent Fault Record	2: Over-current during deceleration (ocd)	0	<input type="radio"/>	<input type="radio"/>	<input type="radio"/>	<input type="radio"/>	<input type="radio"/>
		3: Over-current during constant speed (ocn)		<input type="radio"/>	<input type="radio"/>	<input type="radio"/>	<input type="radio"/>	<input type="radio"/>
		4: Ground fault (GFF)		<input type="radio"/>	<input type="radio"/>	<input type="radio"/>	<input type="radio"/>	<input type="radio"/>
06-19	Third Most Recent Fault Record	5: IGBT short-circuit (occ)	0	<input type="radio"/>	<input type="radio"/>	<input type="radio"/>	<input type="radio"/>	<input type="radio"/>
		6: Over-current at stop (ocS)		<input type="radio"/>	<input type="radio"/>	<input type="radio"/>	<input type="radio"/>	<input type="radio"/>
		7: Over-voltage during acceleration (ovA)		<input type="radio"/>	<input type="radio"/>	<input type="radio"/>	<input type="radio"/>	<input type="radio"/>
06-20	Fourth Most Recent Fault Record	8: Over-voltage during deceleration (ovd)	0	<input type="radio"/>	<input type="radio"/>	<input type="radio"/>	<input type="radio"/>	<input type="radio"/>
		9: Over-voltage during constant speed (ovn)		<input type="radio"/>	<input type="radio"/>	<input type="radio"/>	<input type="radio"/>	<input type="radio"/>
		10: Over-voltage at stop (ovS)		<input type="radio"/>	<input type="radio"/>	<input type="radio"/>	<input type="radio"/>	<input type="radio"/>
		11: Low-voltage during acceleration (LvA)		<input type="radio"/>	<input type="radio"/>	<input type="radio"/>	<input type="radio"/>	<input type="radio"/>

Chapter 4 Parameters | VFD-VE

Pr.	Explanation	Settings	Factory Setting	VF	VFP	SVC	FOCPG	TQCPG
06-21	Fifth Most Recent Fault Record	12: Low-voltage during deceleration (Lvd)	0	<input type="checkbox"/>	<input type="checkbox"/>	<input type="checkbox"/>	<input type="checkbox"/>	<input type="checkbox"/>
		13: Low-voltage during constant speed (Lvn)		<input type="checkbox"/>	<input type="checkbox"/>	<input type="checkbox"/>	<input type="checkbox"/>	
		14: Low-voltage at stop (LVs)		<input type="checkbox"/>	<input type="checkbox"/>	<input type="checkbox"/>	<input type="checkbox"/>	
		15: Phase loss (PHL)		<input type="checkbox"/>	<input type="checkbox"/>	<input type="checkbox"/>	<input type="checkbox"/>	
		16: IGBT over-heat (oH1)		<input type="checkbox"/>	<input type="checkbox"/>	<input type="checkbox"/>	<input type="checkbox"/>	
06-22	Sixth Most Recent Fault Record	17: Heat sink over-heat (oH2)(for 40HP above)	0	<input type="checkbox"/>	<input type="checkbox"/>	<input type="checkbox"/>	<input type="checkbox"/>	<input type="checkbox"/>
		18: TH1: IGBT hardware failure (tH1o)		<input type="checkbox"/>	<input type="checkbox"/>	<input type="checkbox"/>	<input type="checkbox"/>	
		19: TH2: Heat sink hardware failure(tH2o)		<input type="checkbox"/>	<input type="checkbox"/>	<input type="checkbox"/>	<input type="checkbox"/>	
		20: Fan error signal output		<input type="checkbox"/>	<input type="checkbox"/>	<input type="checkbox"/>	<input type="checkbox"/>	
		21: over-load (oL) (when it exceeds 150% rated current, 1 min later it will be overload)		<input type="checkbox"/>	<input type="checkbox"/>	<input type="checkbox"/>	<input type="checkbox"/>	
		22: Electronics thermal relay 1 (EoL1)		<input type="checkbox"/>	<input type="checkbox"/>	<input type="checkbox"/>	<input type="checkbox"/>	
		23: Electronics thermal relay 2 (EoL2)		<input type="checkbox"/>	<input type="checkbox"/>	<input type="checkbox"/>	<input type="checkbox"/>	
		24: Motor PTC overheat (oH3)		<input type="checkbox"/>	<input type="checkbox"/>	<input type="checkbox"/>	<input type="checkbox"/>	
		25: Fuse error (FuSE)		<input type="checkbox"/>	<input type="checkbox"/>	<input type="checkbox"/>	<input type="checkbox"/>	
		26: over-torque 1 (ot1)		<input type="checkbox"/>	<input type="checkbox"/>	<input type="checkbox"/>	<input type="checkbox"/>	
		27: over-torque 1 (ot2)		<input type="checkbox"/>	<input type="checkbox"/>	<input type="checkbox"/>	<input type="checkbox"/>	
		28: Reserved						
		29: Reserved						
		30: Memory write-in error (cF1)		<input type="checkbox"/>	<input type="checkbox"/>	<input type="checkbox"/>	<input type="checkbox"/>	
		31: Memory read-out error (cF2)		<input type="checkbox"/>	<input type="checkbox"/>	<input type="checkbox"/>	<input type="checkbox"/>	
		32: Isum current detection error (cd0)		<input type="checkbox"/>	<input type="checkbox"/>	<input type="checkbox"/>	<input type="checkbox"/>	
		33: U-phase current detection error (cd1)		<input type="checkbox"/>	<input type="checkbox"/>	<input type="checkbox"/>	<input type="checkbox"/>	
		34: V-phase current detection error (cd2)		<input type="checkbox"/>	<input type="checkbox"/>	<input type="checkbox"/>	<input type="checkbox"/>	
		35: W-phase current detection error (cd3)		<input type="checkbox"/>	<input type="checkbox"/>	<input type="checkbox"/>	<input type="checkbox"/>	
		36: Clamp current detection error (Hd0)		<input type="checkbox"/>	<input type="checkbox"/>	<input type="checkbox"/>	<input type="checkbox"/>	
		37: Over-current detection error (Hd1)		<input type="checkbox"/>	<input type="checkbox"/>	<input type="checkbox"/>	<input type="checkbox"/>	
		38: Over-voltage detection error (Hd2)		<input type="checkbox"/>	<input type="checkbox"/>	<input type="checkbox"/>	<input type="checkbox"/>	
		39: Ground current detection error (Hd3)		<input type="checkbox"/>	<input type="checkbox"/>	<input type="checkbox"/>	<input type="checkbox"/>	
		40: Auto tuning error (AuE)				<input type="checkbox"/>	<input type="checkbox"/>	
		41: PID feedback loss (AFE)		<input type="checkbox"/>	<input type="checkbox"/>	<input type="checkbox"/>	<input type="checkbox"/>	
		42: PG feedback error (PGF1)			<input type="checkbox"/>	<input type="checkbox"/>	<input type="checkbox"/>	
		43: PG feedback loss (PGF2)			<input type="checkbox"/>	<input type="checkbox"/>	<input type="checkbox"/>	
		44: PG feedback stall (PGF3)			<input type="checkbox"/>	<input type="checkbox"/>	<input type="checkbox"/>	
		45: PG slip error (PGF4)			<input type="checkbox"/>	<input type="checkbox"/>	<input type="checkbox"/>	
		46: PG ref input error (PGr1)		<input type="checkbox"/>	<input type="checkbox"/>	<input type="checkbox"/>	<input type="checkbox"/>	
		47: PG ref loss (PGr2)		<input type="checkbox"/>	<input type="checkbox"/>	<input type="checkbox"/>	<input type="checkbox"/>	
		48: Analog current input loss (ACE)		<input type="checkbox"/>	<input type="checkbox"/>	<input type="checkbox"/>	<input type="checkbox"/>	
		49: External fault input (EF)		<input type="checkbox"/>	<input type="checkbox"/>	<input type="checkbox"/>	<input type="checkbox"/>	
		50: Emergency stop (EF1)		<input type="checkbox"/>	<input type="checkbox"/>	<input type="checkbox"/>	<input type="checkbox"/>	
		51: External Base Block (B.B.)		<input type="checkbox"/>	<input type="checkbox"/>	<input type="checkbox"/>	<input type="checkbox"/>	
52: Password error (PcodE)	<input type="checkbox"/>	<input type="checkbox"/>	<input type="checkbox"/>	<input type="checkbox"/>				
53: Reserved								
54: Communication error (cE1)	<input type="checkbox"/>	<input type="checkbox"/>	<input type="checkbox"/>	<input type="checkbox"/>				
55: Communication error (cE2)	<input type="checkbox"/>	<input type="checkbox"/>	<input type="checkbox"/>	<input type="checkbox"/>				
56: Communication error (cE3)	<input type="checkbox"/>	<input type="checkbox"/>	<input type="checkbox"/>	<input type="checkbox"/>				
57: Communication error (cE4)	<input type="checkbox"/>	<input type="checkbox"/>	<input type="checkbox"/>	<input type="checkbox"/>				
58: Communication Time-out (cE10)	<input type="checkbox"/>	<input type="checkbox"/>	<input type="checkbox"/>	<input type="checkbox"/>				
59: PU time-out (cP10)	<input type="checkbox"/>	<input type="checkbox"/>	<input type="checkbox"/>	<input type="checkbox"/>				
60: Brake transistor error (bF)	<input type="checkbox"/>	<input type="checkbox"/>	<input type="checkbox"/>	<input type="checkbox"/>				
61: Y-connection/ Δ -connection switch error (ydc)	<input type="checkbox"/>	<input type="checkbox"/>	<input type="checkbox"/>	<input type="checkbox"/>				
62: Decel. Energy Backup Error (dEb)	<input type="checkbox"/>	<input type="checkbox"/>	<input type="checkbox"/>	<input type="checkbox"/>				
63: Slip error (oS1)	<input type="checkbox"/>	<input type="checkbox"/>	<input type="checkbox"/>	<input type="checkbox"/>				
64: Broken belt error (bEb)	<input type="checkbox"/>	<input type="checkbox"/>	<input type="checkbox"/>	<input type="checkbox"/>				
65: Error PID feedback signal of tension (tdEv)	<input type="checkbox"/>	<input type="checkbox"/>	<input type="checkbox"/>	<input type="checkbox"/>				
↗06-23	Fault Output Option 1	0~65535 (refer to bit table for fault code)	0	<input type="checkbox"/>	<input type="checkbox"/>	<input type="checkbox"/>	<input type="checkbox"/>	<input type="checkbox"/>
↗06-24	Fault Output Option 2	0~65535 (refer to bit table for fault code)	0	<input type="checkbox"/>	<input type="checkbox"/>	<input type="checkbox"/>	<input type="checkbox"/>	<input type="checkbox"/>
↗06-25	Fault Output Option 3	0~65535 (refer to bit table for fault code)	0	<input type="checkbox"/>	<input type="checkbox"/>	<input type="checkbox"/>	<input type="checkbox"/>	<input type="checkbox"/>
↗06-26	Fault Output Option 4	0~65535 (refer to bit table for fault code)	0	<input type="checkbox"/>	<input type="checkbox"/>	<input type="checkbox"/>	<input type="checkbox"/>	<input type="checkbox"/>
↗06-27	Electronic Thermal Relay Selection (Motor 2)	0: Inverter motor 1: Standard motor 2: Disable	2	<input type="checkbox"/>	<input type="checkbox"/>	<input type="checkbox"/>	<input type="checkbox"/>	<input type="checkbox"/>

Pr.	Explanation	Settings	Factory Setting	VF	VFP	SVC	FOCPG	TQCPG
↗ 06-28	Electronic Thermal Characteristic for Motor 2	30.0~600.0 sec	60.0	<input type="radio"/>	<input type="radio"/>	<input type="radio"/>	<input type="radio"/>	<input type="radio"/>
↗ 06-29	PTC (Positive Temperature Coefficient) Detection Selection	0: Warn and keep operation 1: Warn and ramp to stop 2: Warn and coast to stop	0	<input type="radio"/>	<input type="radio"/>	<input type="radio"/>	<input type="radio"/>	<input type="radio"/>
↗ 06-30	PTC Level	0.0~100.0%	50.0	<input type="radio"/>	<input type="radio"/>	<input type="radio"/>	<input type="radio"/>	<input type="radio"/>
↗ 06-31	Filter Time for PTC Detection	0.00~10.00sec	0.20	<input type="radio"/>	<input type="radio"/>	<input type="radio"/>	<input type="radio"/>	<input type="radio"/>
06-32	Output Frequency for Malfunction	0.00~655.35 Hz	Read-only	<input type="radio"/>	<input type="radio"/>	<input type="radio"/>	<input type="radio"/>	<input type="radio"/>
06-33	Output Voltage for Malfunction	0.0~6553.5 V	Read-only	<input type="radio"/>	<input type="radio"/>	<input type="radio"/>	<input type="radio"/>	<input type="radio"/>
06-34	DC Voltage for Malfunction	0.0~6553.5 V	Read-only	<input type="radio"/>	<input type="radio"/>	<input type="radio"/>	<input type="radio"/>	<input type="radio"/>
06-35	Output Current for Malfunction	0.00~655.35 Amp	Read-only	<input type="radio"/>	<input type="radio"/>	<input type="radio"/>	<input type="radio"/>	<input type="radio"/>
06-36	IGBT Temperature for Malfunction	0.0~6553.5 °C	Read-only	<input type="radio"/>	<input type="radio"/>	<input type="radio"/>	<input type="radio"/>	<input type="radio"/>

Group 7 Special Parameters

Pr.	Explanation	Settings	Factory Setting	VF	VFPG	SVC	FOCPG	TQCPG
↗07-00	Software Brake Level	230V: 350.0~450.0Vdc 460V: 700.0~900.0Vdc	380.0 760.0	<input type="checkbox"/>	<input type="checkbox"/>	<input type="checkbox"/>	<input type="checkbox"/>	<input type="checkbox"/>
↗07-01	DC Brake Current Level	0~100%	0				<input type="checkbox"/>	<input type="checkbox"/>
↗07-02	DC Brake Time at Start-up	0.0~60.0 sec	0.0				<input type="checkbox"/>	<input type="checkbox"/>
↗07-03	DC Brake Time at Stop	0.0~60.0 sec	0.0				<input type="checkbox"/>	<input type="checkbox"/>
↗07-04	Start-point for DC Brake	0.00~600.00Hz	0.00	<input type="checkbox"/>	<input type="checkbox"/>	<input type="checkbox"/>		
↗07-05	Proportional Gain for DC Brake	1~500	50	<input type="checkbox"/>	<input type="checkbox"/>	<input type="checkbox"/>		
↗07-06	Momentary Power Loss Operation Selection	0: Operation stop after momentary power loss 1: Operation continues after momentary power loss, speed search starts with the Master Frequency reference value 2: Operation continues after momentary power loss, speed search starts with the minimum frequency	0	<input type="checkbox"/>	<input type="checkbox"/>	<input type="checkbox"/>	<input type="checkbox"/>	<input type="checkbox"/>
↗07-07	Maximum Allowable Power Loss Time	0.1~5.0 sec	2.0	<input type="checkbox"/>	<input type="checkbox"/>	<input type="checkbox"/>	<input type="checkbox"/>	<input type="checkbox"/>
↗07-08	B.B. Time for Speed Search	0.1~5.0 sec	0.5	<input type="checkbox"/>	<input type="checkbox"/>	<input type="checkbox"/>	<input type="checkbox"/>	<input type="checkbox"/>
↗07-09	Current Limit for Speed Search	20~200%	150	<input type="checkbox"/>	<input type="checkbox"/>	<input type="checkbox"/>	<input type="checkbox"/>	<input type="checkbox"/>
↗07-10	Base-block Speed Search	0: Stop operation 1: Speed search starts with last frequency command 2: Speed search starts with minimum output frequency	0	<input type="checkbox"/>	<input type="checkbox"/>	<input type="checkbox"/>	<input type="checkbox"/>	<input type="checkbox"/>
↗07-11	Auto Restart after Fault	0~10	0	<input type="checkbox"/>	<input type="checkbox"/>	<input type="checkbox"/>	<input type="checkbox"/>	<input type="checkbox"/>
↗07-12	Speed Search during Start-up	0: Disable 1: Speed search from maximum frequency 2: Speed search from start-up frequency 3: Speed search from minimum frequency	0	<input type="checkbox"/>	<input type="checkbox"/>	<input type="checkbox"/>		
↗07-13	Decel. Time Selection for Momentary Power Loss	0: Disable 1: 1 st decel. time 2: 2 nd decel. time 3: 3 rd decel. time 4: 4 th decel. time 5: Current decel. time 6: Auto decel. Time	0	<input type="checkbox"/>	<input type="checkbox"/>	<input type="checkbox"/>	<input type="checkbox"/>	<input type="checkbox"/>
↗07-14	DEB Return Time	0.0~25.0 sec	0.0	<input type="checkbox"/>	<input type="checkbox"/>	<input type="checkbox"/>	<input type="checkbox"/>	
↗07-15	Dwell Time at Accel.	0.00~600.00sec	0.00	<input type="checkbox"/>	<input type="checkbox"/>	<input type="checkbox"/>	<input type="checkbox"/>	
↗07-16	Dwell Frequency at Accel.	0.00~600.00Hz	0.00	<input type="checkbox"/>	<input type="checkbox"/>	<input type="checkbox"/>	<input type="checkbox"/>	
↗07-17	Dwell Time at Decel.	0.00~600.00sec	0.00	<input type="checkbox"/>	<input type="checkbox"/>	<input type="checkbox"/>	<input type="checkbox"/>	
↗07-18	Dwell Frequency at Decel.	0.00~600.00Hz	0.00	<input type="checkbox"/>	<input type="checkbox"/>	<input type="checkbox"/>	<input type="checkbox"/>	
↗07-19	Fan Control	0: Fan always ON 1: 1 minute after AC motor drive stops, fan will be OFF 2: AC motor drive runs and fan ON, AC motor drive stops and fan OFF 3: Fan ON to run when preliminary heat sink temperature(around 60°C) attained 4: Fan always OFF	0	<input type="checkbox"/>	<input type="checkbox"/>	<input type="checkbox"/>	<input type="checkbox"/>	<input type="checkbox"/>
↗07-20	Torque Command	-100.0~100.0% (Pr. 07-22 setting=100%)	0.0					<input type="checkbox"/>
↗07-21	Torque Command Source	0: Digital keypad 1: RS485 serial communication (RJ-11) 2: Analog signal (Pr.03-00)	0					<input type="checkbox"/>
↗07-22	Maximum Torque Command	0~500%	100					<input type="checkbox"/>
↗07-23	Filter Time of Torque Command	0.000~1.000 sec	0.000					<input type="checkbox"/>
07-24	Speed Limit Selection	0: By Pr.07-25 and Pr.07-26 1: Frequency command source (Pr.00-20)	0					<input type="checkbox"/>
↗07-25	Torque Mode +Speed Limit	0~120%	10					<input type="checkbox"/>
↗07-26	Torque Mode-Speed Limit	0~120%	10					<input type="checkbox"/>

Pr.	Explanation	Settings	Factory Setting	VF	VFP	SVC	FOCPG	TOCPG
07-27	Source of Torque Offset	0: Disable 1: Analog input (Pr.03-00) 2: Torque offset setting 3: Control by external terminal (by Pr.07-29 to Pr.07-31)	0			<input type="radio"/>	<input type="radio"/>	<input type="radio"/>
↗07-28	Torque Offset Setting	0.0~100.0%	0.0			<input type="radio"/>	<input type="radio"/>	<input type="radio"/>
↗07-29	High Torque Offset	0.0~100.0%	30.0			<input type="radio"/>	<input type="radio"/>	<input type="radio"/>
↗07-30	Middle Torque Offset	0.0~100.0%	20.0			<input type="radio"/>	<input type="radio"/>	<input type="radio"/>
↗07-31	Low Torque Offset	0.0~100.0%	10.0			<input type="radio"/>	<input type="radio"/>	<input type="radio"/>
↗07-32	Forward Motor Torque Limit	0~500%	200				<input type="radio"/>	<input type="radio"/>
↗07-33	Forward Regenerative Torque Limit	0~500%	200				<input type="radio"/>	<input type="radio"/>
↗07-34	Reverse Motor Torque Limit	0~500%	200				<input type="radio"/>	<input type="radio"/>
↗07-35	Reverse Regenerative Torque Limit	0~500%	200				<input type="radio"/>	<input type="radio"/>
07-36	Emergency Stop (EF) & Forced Stop Selection	0: Coast stop 1: By deceleration Time 1 2: By deceleration Time 2 3: By deceleration Time 3 4: By deceleration Time 4 5: System Deceleration 6: Automatic Deceleration	0	<input type="radio"/>	<input type="radio"/>	<input type="radio"/>	<input type="radio"/>	<input type="radio"/>

Group 8 High-function PID Parameters

Pr.	Explanation	Settings	Factory Setting	VF	VFPG	SVC	FOCPG	TQCPG
08-00	Input Terminal for PID Feedback	0: No function 1: Negative PID feedback from external terminal AVI (Pr.03-00) 2: Negative PID feedback from PG card (Pr.10-15, skip direction) 3: Negative PID feedback from PG card (Pr.10-15) 4: Positive PID feedback from external terminal AVI (Pr.03-00) 5: Positive PID feedback from PG card (Pr.10-15, skip direction) 6: Positive PID feedback from PG card (Pr.10-15)	0	<input type="radio"/>	<input type="radio"/>	<input type="radio"/>	<input type="radio"/>	
↗08-01	Proportional Gain (P)	0.0~500.0%	80.0	<input type="radio"/>	<input type="radio"/>	<input type="radio"/>	<input type="radio"/>	
↗08-02	Integral Gain (I)	0.00~100.00 sec	1.00	<input type="radio"/>	<input type="radio"/>	<input type="radio"/>	<input type="radio"/>	
↗08-03	Derivative Control (D)	0.00~1.00 sec	0.00	<input type="radio"/>	<input type="radio"/>	<input type="radio"/>	<input type="radio"/>	
↗08-04	Upper limit for Integral Control	0.0~100.0%	100.0	<input type="radio"/>	<input type="radio"/>	<input type="radio"/>	<input type="radio"/>	
↗08-05	PID Output Frequency Limit	0.0~110.0%	100.0	<input type="radio"/>	<input type="radio"/>	<input type="radio"/>	<input type="radio"/>	
↗08-06	PID Offset	-100.0~+100.0%	0.0	<input type="radio"/>	<input type="radio"/>	<input type="radio"/>	<input type="radio"/>	
↗08-07	PID Delay Time	0.0~2.5 sec	0.0	<input type="radio"/>	<input type="radio"/>	<input type="radio"/>	<input type="radio"/>	
↗08-08	Feedback Signal Detection Time	0.0~3600.0 sec	0.0	<input type="radio"/>	<input type="radio"/>	<input type="radio"/>	<input type="radio"/>	
08-09	Feedback Fault Treatment	0: Warn and keep operating 1: Warn and ramp to stop 2: Warn and coast to stop 3: Warn and keep at last frequency	0	<input type="radio"/>	<input type="radio"/>	<input type="radio"/>	<input type="radio"/>	
↗08-10	Sleep Frequency	0.00~600.00Hz	0.00	<input type="radio"/>	<input type="radio"/>	<input type="radio"/>	<input type="radio"/>	
↗08-11	Wake-up Frequency	0.00~600.00Hz	0.00	<input type="radio"/>	<input type="radio"/>	<input type="radio"/>	<input type="radio"/>	
↗08-12	Sleep Time	0.0~6000.0 sec	0.0	<input type="radio"/>	<input type="radio"/>	<input type="radio"/>	<input type="radio"/>	
↗08-13	PID Deviation Level	1.0~50.0%	10.0	<input type="radio"/>	<input type="radio"/>	<input type="radio"/>	<input type="radio"/>	
↗08-14	PID Deviation Time	0.1~300.0 sec	5.0	<input type="radio"/>	<input type="radio"/>	<input type="radio"/>	<input type="radio"/>	
↗08-15	Filter Time for PID Feedback	0.1~300.0 sec	5.0	<input type="radio"/>	<input type="radio"/>	<input type="radio"/>	<input type="radio"/>	
08-16 08-20	Reserved							
08-21	Tension Control Selection	0: Disable 1: Tension closed-loop, speed mode 2: Line speed closed-loop, speed mode 3: Tension close-loop, torque mode 4: Tension open-loop, torque mode	0	<input type="radio"/>	<input type="radio"/>	<input type="radio"/>	<input type="radio"/>	<input type="radio"/>
08-22	Wind Mode	0: Rewind 1: Unwind	0	<input type="radio"/>	<input type="radio"/>	<input type="radio"/>	<input type="radio"/>	<input type="radio"/>
08-23	Mechanical Gear A at Reel	1-65535	100	<input type="radio"/>	<input type="radio"/>	<input type="radio"/>	<input type="radio"/>	<input type="radio"/>
08-24	Mechanical Gear B at Motor	1-65535	100	<input type="radio"/>	<input type="radio"/>	<input type="radio"/>	<input type="radio"/>	<input type="radio"/>
08-25	Source of the Tension Command/Line Speed	0: Parameter setting (Pr.08-26) 1: RS-485 communication setting (Pr.08-26) 2: Analog input (Pr. 03-00~03-02=14 PID target value of tension, 03-00~03-02=12 line speed)	0	<input type="radio"/>	<input type="radio"/>	<input type="radio"/>	<input type="radio"/>	
↗08-26	PID Target Value of Tension/Line Speed	0.0~100.0%	50.0	<input type="radio"/>	<input type="radio"/>	<input type="radio"/>	<input type="radio"/>	
08-27	Source of Tension/Line Speed PID Feedback	0: Analog input (Pr. 03-00~03-02 is set to 11 PID feedback of tension) 1: Pulse input (Pr.08-40)	0	<input type="radio"/>	<input type="radio"/>	<input type="radio"/>	<input type="radio"/>	
08-28	Auto-tuning Tension PID	0: Disable 1: Reel diameter (08-29~08-30 corresponds to 08-44, 08-32~08-33 corresponds to 08-43) 2: Frequency (08-29~08-30 corresponds to 01-07, 08-32~08-33 corresponds to 01-00)		<input type="radio"/>	<input type="radio"/>	<input type="radio"/>	<input type="radio"/>	
↗08-29	Proportional Gain 1 of Tension PID P	0.0~1000.0	50.0	<input type="radio"/>	<input type="radio"/>	<input type="radio"/>	<input type="radio"/>	
↗08-30	Integral Time of Tension PID I	0.00~500.00 sec	1.00	<input type="radio"/>	<input type="radio"/>	<input type="radio"/>	<input type="radio"/>	

Pr.	Explanation	Settings	Factory Setting	VF	VFPG	SVC	FOCPG	TOCPG
08-31	Reserved							
↗08-32	Proportional Gain 2 of Tension PID P	0.0~1000.0	50.0	○	○	○	○	
↗08-33	Integral Time 2 of Tension PID I	0.00~500.00 sec	1.00	○	○	○	○	
08-34	Reserved							
08-35	PID/Line Speed Output Status	0: Positive output 1: Negative output	0	○	○	○	○	
08-36	Tension/Line Speed PID Output Limit	0~100.00%	20.00	○	○	○	○	
08-37	Source of Line Speed Input Command	0: Disable 1: Analog input (Pr. 03-00~03-02 is set to 12 line speed) 2: RS-485 communication setting (Pr.08-41) 3: Pulse input (Pr.08-40) 4: DFM-DCM pulse input (Pr.02-18)	0	○	○	○	○	○
08-38	Max. Line Speed	0.0~3000.0m/min	1000.0	○	○	○	○	○
08-39	Min. Line Speed	0.0~3000.0m/min	0.0	○	○	○	○	○
08-40	Pulse Number for Each Meter	0.0~6000.0 pulse/m	0.0	○	○	○	○	○
08-41	Current Line Speed	0.0~3000.0m/min	0.0	○	○	○	○	○
08-42	Source of Reel Diameter	0: Calculated by line speed 1: Calculated by integrating thickness (encoder is on reel shaft)(Pr.08-49~51, Pr.10-15) 2: Calculated by integrating thickness (encoder is on motor)(Pr.08-23~08-24, 08-50~08-51, 10-00~10-01) 3: Calculated by analog input (Pr.03-00~03-02 is set to 13)	0	○	○	○	○	○
08-43	Max. Reel Diameter	1.0~6000.0mm	6000.0	○	○	○	○	○
08-44	Empty Reel Diameter	1.0~6000.0mm	1.0	○	○	○	○	○
08-45	Source of Initial Reel Diameter	0: RS-485 communication setting (Pr.08-46) 1: Analog input (Pr.03-00-Pr.03-02 is set to 13)	0	○	○	○	○	○
08-46	Initial Reel Diameter	0.0~6000.0mm	1.0	○	○	○	○	○
08-47	Initial Reel Diameter 1	0.0~6000.0mm	1.0	○	○	○	○	○
08-48	Initial Reel Diameter 2	0.0~6000.0mm	1.0	○	○	○	○	○
08-49	Number of Pulse per Revolution	1~1000ppr	1	○	○	○	○	○
08-50	Coil Number for Each Layer	0.001~60.000mm	1.000	○	○	○	○	○
08-51	Material Thickness	0.001~60.000mm	1.000	○	○	○	○	○
↗08-52	Filter Time of Reel Diameter	0.00 to 100.00 seconds	1.00	○	○	○	○	○
08-53	Auto Compensation of Reel Diameter	0: Disable 1: Enable	1.00	○	○	○	○	○
↗08-54	Current Reel Diameter	1.0~6000.0mm	1.0	○	○	○	○	○
08-55	Smart Start Function	0: Disable 1: Enable 2: In unwind mode, rewind in reverse direction	1	○	○	○	○	○
08-56	Switch Level for Smart Start and PID function	0.0~100.00% (according to Pr.08-26)	15.0	○	○	○	○	○
08-57	Frequency for Smart Start	0.00~600.00Hz	2.00	○	○	○	○	○
↗08-58	Accel. Time for Smart Start	0.01~600.00 seconds	3.00	○	○	○	○	○
08-59	Broken Belt Detection	0: Disable 1: Enable	0	○	○	○	○	○
08-60	Min. Line Speed of Broken Belt Detection	0.0~3000.0m/min	0.0	○	○	○	○	○
08-61	Allowance Difference of Reel Diameter of Broken Belt Detection	1.0~6000.0mm	100.0	○	○	○	○	○
08-62	Detection Time of Broken Belt	0.00~100.00 sec	1.00	○	○	○	○	○
08-63	Allowance Error Level of Tension/Line Speed PID Feedback	0~100%	100	○	○	○	○	○
08-64	Allowance Error Detection Time of Tension/Line Speed PID Feedback	0.0~10.0 sec	0.5	○	○	○	○	○

Chapter 4 Parameters | VFD-VE

Pr.	Explanation	Settings	Factory Setting	VF	VFPG	SVC	FOCPG	TQCPG
08-65	Error Treatment of Tension/Line Speed PID Feedback	0: Warn and keep operation 1: Warn and coast to stop 2: Warn and ramp to stop	0	<input type="radio"/>	<input type="radio"/>	<input type="radio"/>	<input type="radio"/>	
08-66	Upper Limit of Tension PID Feedback	0.0~100.0%	100.0	<input type="radio"/>	<input type="radio"/>	<input type="radio"/>	<input type="radio"/>	<input type="radio"/>
08-67	Lower Limit of Tension PID Feedback	0.0~100.0%	0.0	<input type="radio"/>	<input type="radio"/>	<input type="radio"/>	<input type="radio"/>	<input type="radio"/>
08-68	Reserved							
08-69	DFM Selection	0: Output frequency 1: Frequency command	0	<input type="radio"/>	<input type="radio"/>	<input type="radio"/>	<input type="radio"/>	<input type="radio"/>
08-70	Low-pass Filter Time of Line Speed	0.00~100.00 sec	0.00	<input type="radio"/>	<input type="radio"/>	<input type="radio"/>	<input type="radio"/>	<input type="radio"/>
08-71 08-75	Reserved							
08-76	Source of Tension Setting	0: Communication RS-485 (Pr.08-78) 1: Analog input (Pr. 03-00~03-02 is set to 15 tension setting) (Pr.08-78)	0					<input type="radio"/>
08-77	Max. Tension	0~30000 N	0					<input type="radio"/>
08-78	Tension Setting	0~30000 N	0					<input type="radio"/>
08-79	Source of Zero-speed Tension Setting	0: Disable 1: Communication RS-485 (Pr.08-80) 2: Analog input (Pr. 03-00~03-02 is set to 16 zero-speed tension) (Pr.08-80)	0					<input type="radio"/>
08-80	Setting of Zero-speed Tension	0~30000 N	0					<input type="radio"/>
08-81	Source of Tension Taper	0: Communication RS-485 (Pr.08-82) 1: Analog input (Pr. 03-00~03-02 is set to 17 tension taper)(Pr.08-82)	0					<input type="radio"/>
08-82	Tension Taper	0~100%	0					<input type="radio"/>
08-83	Friction Compensation	0.0~100.0%	0.0					<input type="radio"/>
08-84	Compensation Coefficient of Material Inertial	0~30000	0					<input type="radio"/>
08-85	Torque Feedforward Gain	0.0~100.0%	50.0					<input type="radio"/>
08-86	Low Pass Filter Time of Torque Feedforward	0.00~100.00	5.00					<input type="radio"/>
08-87 08-99	Reserved							

Group 9 Communication Parameters

Pr.	Explanation	Settings	Factory Setting	VF	VFPG	SVC	FOCPG	TQCPG
↗09-00	Communication Address	1~254	1	<input type="radio"/>	<input type="radio"/>	<input type="radio"/>	<input type="radio"/>	<input type="radio"/>
↗09-01	COM1 Transmission Speed	4.8~115.2Kbps	9.6	<input type="radio"/>	<input type="radio"/>	<input type="radio"/>	<input type="radio"/>	<input type="radio"/>
↗09-02	COM1 Transmission Fault Treatment	0: Warn and keep operation 1: Warn and ramp to stop 2: Warn and coast to stop 3: No warning and keep operation	3	<input type="radio"/>	<input type="radio"/>	<input type="radio"/>	<input type="radio"/>	<input type="radio"/>
↗09-03	COM1 Time-out Detection	0.0~100.0 sec	0.0	<input type="radio"/>	<input type="radio"/>	<input type="radio"/>	<input type="radio"/>	<input type="radio"/>
↗09-04	COM1 Communication Protocol	0: 7N1 (ASCII) 1: 7N2 (ASCII) 2: 7E1 (ASCII) 3: 7O1 (ASCII) 4: 7E2 (ASCII) 5: 7O2 (ASCII) 6: 8N1 (ASCII) 7: 8N2 (ASCII) 8: 8E1 (ASCII) 9: 8O1 (ASCII) 10: 8E2 (ASCII) 11: 8O2 (ASCII) 12: 8N1 (RTU) 13: 8N2 (RTU) 14: 8E1 (RTU) 15: 8O1 (RTU) 16: 8E2 (RTU) 17: 8O2 (RTU)	1	<input type="radio"/>	<input type="radio"/>	<input type="radio"/>	<input type="radio"/>	<input type="radio"/>
↗09-05	COM2 Transmission Speed (Keypad)	4.8~115.2Kbps	9.6	<input type="radio"/>	<input type="radio"/>	<input type="radio"/>	<input type="radio"/>	<input type="radio"/>
↗09-06	COM2 Transmission Fault Treatment (Keypad)	0: Warn and keep operation 1: Warn and ramp to stop 2: Warn and coast to stop 3: No warning and keep operation	3	<input type="radio"/>	<input type="radio"/>	<input type="radio"/>	<input type="radio"/>	<input type="radio"/>
↗09-07	COM2 Time-out Detection (Keypad)	0.0~100.0 sec	0.0	<input type="radio"/>	<input type="radio"/>	<input type="radio"/>	<input type="radio"/>	<input type="radio"/>
↗09-08	COM2 Communication Protocol (Keypad)	0: 7N1 (ASCII) 1: 7N2 (ASCII) 2: 7E1 (ASCII) 3: 7O1 (ASCII) 4: 7E2 (ASCII) 5: 7O2 (ASCII) 6: 8N1 (ASCII) 7: 8N2 (ASCII) 8: 8E1 (ASCII) 9: 8O1 (ASCII) 10: 8E2 (ASCII) 11: 8O2 (ASCII) 12: 8N1 (RTU) 13: 8N2 (RTU) 14: 8E1 (RTU) 15: 8O1 (RTU) 16: 8E2 (RTU) 17: 8O2 (RTU)	13	<input type="radio"/>	<input type="radio"/>	<input type="radio"/>	<input type="radio"/>	<input type="radio"/>
↗09-09	Response Delay Time	0.0~200.0ms	2.0	<input type="radio"/>	<input type="radio"/>	<input type="radio"/>	<input type="radio"/>	<input type="radio"/>
↗09-10	Transmission Master Frequency	0.00~600.00Hz	60.00	<input type="radio"/>	<input type="radio"/>	<input type="radio"/>	<input type="radio"/>	<input type="radio"/>
↗09-11	Block Transfer 1	0~65535	0	<input type="radio"/>	<input type="radio"/>	<input type="radio"/>	<input type="radio"/>	<input type="radio"/>
↗09-12	Block Transfer 2	0~65535	0	<input type="radio"/>	<input type="radio"/>	<input type="radio"/>	<input type="radio"/>	<input type="radio"/>
↗09-13	Block Transfer 3	0~65535	0	<input type="radio"/>	<input type="radio"/>	<input type="radio"/>	<input type="radio"/>	<input type="radio"/>
↗09-14	Block Transfer 4	0~65535	0	<input type="radio"/>	<input type="radio"/>	<input type="radio"/>	<input type="radio"/>	<input type="radio"/>
↗09-15	Block Transfer 5	0~65535	0	<input type="radio"/>	<input type="radio"/>	<input type="radio"/>	<input type="radio"/>	<input type="radio"/>
↗09-16	Block Transfer 6	0~65535	0	<input type="radio"/>	<input type="radio"/>	<input type="radio"/>	<input type="radio"/>	<input type="radio"/>
↗09-17	Block Transfer 7	0~65535	0	<input type="radio"/>	<input type="radio"/>	<input type="radio"/>	<input type="radio"/>	<input type="radio"/>
↗09-18	Block Transfer 8	0~65535	0	<input type="radio"/>	<input type="radio"/>	<input type="radio"/>	<input type="radio"/>	<input type="radio"/>
↗09-19	Block Transfer 9	0~65535	0	<input type="radio"/>	<input type="radio"/>	<input type="radio"/>	<input type="radio"/>	<input type="radio"/>

Chapter 4 Parameters | **VFD-VE**

Pr.	Explanation	Settings	Factory Setting	VF	VFPG	SVC	FOCPG	TQCPG
↗09-20	Block Transfer 10	0~65535	0	<input type="radio"/>	<input type="radio"/>	<input type="radio"/>	<input type="radio"/>	<input type="radio"/>
09-21	Multi-function Output Status	0~65535	Read-only	<input type="radio"/>	<input type="radio"/>	<input type="radio"/>	<input type="radio"/>	<input type="radio"/>
09-22	Display Digital Value of Analog Output 2	0~4095	Read-only	<input type="radio"/>	<input type="radio"/>	<input type="radio"/>	<input type="radio"/>	<input type="radio"/>
09-23	Display Digital Value of Analog Output 3	0~4095	Read-only	<input type="radio"/>	<input type="radio"/>	<input type="radio"/>	<input type="radio"/>	<input type="radio"/>

Group 10 Speed Feedback Control Parameters

Pr.	Explanation	Settings	Factory Setting	VF	VFP	SVC	FOCPG	TQCPG
10-00	Encoder Pulse	1~20000	600		○		○	○
10-01	Encoder Input Type Setting	0: Disable 1: Phase A leads in a forward run command and phase B leads in a reverse run command 2: Phase B leads in a forward run command and phase A leads in a reverse run command 3: Phase A is a pulse input and phase B is a direction input. (low input=reverse direction, high input=forward direction) 4: Phase A is a pulse input and phase B is a direction input. (low input=forward direction, high input=reverse direction) 5: Single-phase input	0		○		○	○
✓10-02	Encoder Feedback Fault Treatment	0: Warn and keep operation 1: Warn and ramp to stop 2: Warn and coast to stop	2		○		○	○
✓10-03	Detection Time for Encoder Feedback Fault	0.00~10.0 sec	1.0		○		○	○
✓10-04	ASR (Auto Speed Regulation) Control (P) 1	0~40	10		○		○	○
✓10-05	ASR (Auto Speed Regulation) Control (I) 1	0.000~10.000 sec	0.100		○		○	○
✓10-06	ASR (Auto Speed Regulation) Control (P) 2	0~40	10		○		○	○
✓10-07	ASR (Auto Speed Regulation) Control (I) 2	0.000~10.000 sec	0.100		○		○	○
✓10-08	ASR 1/ASR2 Switch Frequency	5.00~600.00Hz	7.00		○		○	○
✓10-09	Low Pass Filter Time of ASR Output	0.000~0.350 sec	0.008				○	○
✓10-10	Encoder Stall Level	0~120% (0: disable)	115		○		○	
✓10-11	Encoder Stall Detection Time	0.0~2.0 sec	0.1		○		○	
✓10-12	Encoder Slip Range	0~50% (0: disable)	50		○		○	
✓10-13	Encoder Slip Detection Time	0.0~10.0 sec	0.5		○		○	
✓10-14	Encoder Stall and Slip Error Treatment	0: Warn and keep operation 1: Warn and ramp to stop 2: Warn and coast to stop	2		○		○	
✓10-15	Pulse Input Type Setting	0: Disable 1: Phase A leads in a forward run command and phase B leads in a reverse run command 2: Phase B leads in a forward run command and phase A leads in a reverse run command 3: Phase A is a pulse input and phase B is a direction input. (low input=reverse direction, high input=forward direction) 4: Phase A is a pulse input and phase B is a direction input. (low input=forward direction, high input=reverse direction)	0	○	○	○	○	○
✓10-16	Output Setting for Frequency Division (denominator)	1~255	1		○		○	○
✓10-17	Electrical Gear A (PG 1 of PG card)	1~5000	100		○		○	
✓10-18	Electrical Gear B (PG2 of PG card)	1~5000	100		○		○	
✓10-19	Positioning for Encoder Position	0~65535 pulses	0		○		○	
✓10-20	Range for Encoder Position Attained	0~20000 pulses	10		○		○	

Chapter 4 Parameters | **VFD-VE**

Pr.	Explanation	Settings	Factory Setting	VF	VFPG	SVC	FOCPG	TQCPG
↗10-21	P Gain of Zero Speed	0~40	10		○		○	○
↗10-22	I Gain of Zero Speed	0.000~10.000 sec	0.100		○		○	○
↗10-23	Feed Forward Gain of APR	0~100	30		○		○	
↗10-24	Deceleration Time for Internal Position/Waiting Time for Switching Max. Frequency	0.00~600.00 sec/00~6000.0 sec	3.00 3.0		○		○	
↗10-25	Max. Frequency for Resolution Switch	0.00~600.00Hz	50.00	○	○	○	○	○
10-26	Reserved							
↗10-27	Mechanical Gear at Load A1	1~65535	100		○		○	○
↗10-28	Mechanical Gear at Motor B1	1~65535	100		○		○	○
↗10-29	Mechanical Gear at Load A2	1~65535	100		○		○	○
↗10-30	Mechanical Gear at Motor B2	1~65535	100		○		○	○

Group 11 Advanced Parameters

Pr.	Explanation	Settings	Factory Setting	VF	VFPG	SVC	FOCPG	TQCPG
11-00	System Control	bit 0: Auto tuning for ASR and APR bit 1: Inertia estimate (only for FOCPG mode) bit 2: Zero Servo bit 3: Reserved	0				○	○
↗11-01	Per Unit of System Inertia	1~65535 (256=1PU)	400				○	○
↗11-02	Low-speed Bandwidth	0~40Hz	10		○		○	○
↗11-03	High-speed Bandwidth	0~40Hz	10		○		○	○
↗11-04	PDF Gain Value	0~200%	30				○	
↗11-05	Gain Value of Flux Weakening Curve for Motor 1	0~200%	90				○	○
↗11-06	Gain Value of Flux Weakening Curve for Motor 2	0~200%	90				○	○
↗11-07	Detection Time for Phase-loss	0.01~600.00 sec	0.20	○	○	○	○	○
11-08	Reserved							
↗11-09	Level of Phase-loss	0.0~320.0	60.0	○	○	○	○	○
↗11-10	Speed Feed Forward Gain	0~100%	0				○	○
↗11-11	Zero-speed Bandwidth	0~40Hz	10		○		○	○
↗11-12	Speed Response of Flux Weakening Area	0: Disable 0~150%	65				○	
↗11-13	Notch Filter Depth	0~20db	0				○	
↗11-14	Notch Filter Frequency	0.00~200.00	0.00				○	
↗11-15	Gain Value of Slip Compensation	0.00~1.00	1.00			○		
↗11-16	Low-pass Filter Time of Keypad Display	0.001~65.535sec	0.100	○	○	○	○	○
↗11-17	Low-pass Filter Time of PG2 Pulse Input	0.000~65.535sec	0.100	○	○	○	○	○
↗11-18	APR Gain	0.00~40.00	10.00				○	
↗11-19	APR Curve Time	0.00~655.35 sec	3.00				○	
11-20 11-28	Reserved							
11-29	Accumulative Operation Time of Phase-loss	0~65535 (hour)	0	○	○	○	○	○

Pr.	Explanation	Settings	Factory Setting	VF	VFPG	SVC	FOCPG	TQCPG
11-30 11-40	Reserved							

4.2 Version Differences

4.2.1 Version 2.02

New or update parameter groups are:

Group 2: Digital Input/Output Parameters

Group 3: Analog Input/Output Parameters

Group 6: Protection Parameters

Group 8: High-function PID Parameters

Group 10: Speed Feedback Control Parameters

Version 2.02

Group 2 Digital Input/Output Parameters

New settings are marked in bold. In version 2.02, the parameters are from Pr.02-00 to Pr.02-34.

Pr.	Explanation	Settings	Factory Setting	VF	VFPG	SVC	FOCPG	TOCPG
02-01	Multi-Function Input Command 1 (MI1) (it is Stop terminal for 3-wire operation)	27: ASR1/ASR2 selection			<input type="radio"/>		<input type="radio"/>	
02-02	Multi-Function Input Command 2 (MI2)	28: Emergency stop (EF1)		<input type="radio"/>	<input type="radio"/>	<input type="radio"/>	<input type="radio"/>	<input type="radio"/>
02-03	Multi-Function Input Command 3 (MI3)	29: Signal confirmation for Y-connection		<input type="radio"/>	<input type="radio"/>	<input type="radio"/>		
02-04	Multi-Function Input Command 4 (MI4)	30: Signal confirmation for Δ-connection		<input type="radio"/>	<input type="radio"/>	<input type="radio"/>		
02-05	Multi-Function Input Command 5 (MI5)	31: High torque bias (by Pr.07-29)		<input type="radio"/>	<input type="radio"/>	<input type="radio"/>	<input type="radio"/>	<input type="radio"/>
02-06	Multi-Function Input Command 6 (MI6) (specific terminal for TRG)	32: Middle torque bias (by Pr.07-30)		<input type="radio"/>	<input type="radio"/>	<input type="radio"/>	<input type="radio"/>	<input type="radio"/>
02-23	Multi-Function Input Command 7	33: Low torque bias (by Pr.07-31)		<input type="radio"/>	<input type="radio"/>	<input type="radio"/>	<input type="radio"/>	<input type="radio"/>
02-24	Multi-Function Input Command 8	34: Enable multi-step position control		<input type="radio"/>	<input type="radio"/>	<input type="radio"/>		
02-25	Multi-Function Input Command 9	35: Enable position control		<input type="radio"/>	<input type="radio"/>	<input type="radio"/>		
02-26	Multi-Function Input Command 10	36: Enable position learning function (valid at stop)		<input type="radio"/>	<input type="radio"/>	<input type="radio"/>		
02-27	Multi-Function Input Command 11	37: Enable pulse position input command		<input type="radio"/>	<input type="radio"/>	<input type="radio"/>		
02-28	Multi-Function Input Command 12	38: Disable write EEPROM function		<input type="radio"/>	<input type="radio"/>	<input type="radio"/>	<input type="radio"/>	<input type="radio"/>
02-29	Multi-Function Input Command 13	39: Torque command direction		<input type="radio"/>	<input type="radio"/>	<input type="radio"/>		<input type="radio"/>
02-30	Multi-Function Input Command 14	40: Force stop		<input type="radio"/>	<input type="radio"/>	<input type="radio"/>	<input type="radio"/>	<input type="radio"/>
		41: Serial position clock					<input type="radio"/>	
		42: Serial position input					<input type="radio"/>	
		43: Analog input resolution selection					<input type="radio"/>	
↗02-11	Multi-function Output 1 RA, RB, RC(Relay1)	29: Output when frequency >= Pr.02-33		<input type="radio"/>	<input type="radio"/>	<input type="radio"/>	<input type="radio"/>	<input type="radio"/>
↗02-12	Multi-function Output 2 MRA, MRC (Relay2)	30: Output when frequency < Pr.02-33		<input type="radio"/>	<input type="radio"/>	<input type="radio"/>	<input type="radio"/>	<input type="radio"/>
↗02-13	Multi-function Output 3 (MO1)	31: Y-connection for the motor coil		<input type="radio"/>	<input type="radio"/>	<input type="radio"/>	<input type="radio"/>	
↗02-14	Multi-function Output 4 (MO2)	32: Δ connection for the motor coil		<input type="radio"/>	<input type="radio"/>	<input type="radio"/>	<input type="radio"/>	
↗02-35	Multi-function Output 5 (MO3)	33: Zero speed (actual output frequency)		<input type="radio"/>	<input type="radio"/>	<input type="radio"/>	<input type="radio"/>	
↗02-36	Multi-function Output 6 (MO4)	34: Zero speed with Stop (actual output frequency)		<input type="radio"/>	<input type="radio"/>	<input type="radio"/>	<input type="radio"/>	
↗02-37	Multi-function Output 7 (MO5)	35: Error output selection 1 (Pr.06-23)		<input type="radio"/>	<input type="radio"/>	<input type="radio"/>	<input type="radio"/>	<input type="radio"/>
↗02-38	Multi-function Output 8 (MO6)	36: Error output selection 2 (Pr.06-24)		<input type="radio"/>	<input type="radio"/>	<input type="radio"/>	<input type="radio"/>	<input type="radio"/>
↗02-39	Multi-function Output 9 (MO7)	37: Error output selection 3 (Pr.06-25)		<input type="radio"/>	<input type="radio"/>	<input type="radio"/>	<input type="radio"/>	<input type="radio"/>
↗02-40	Multi-function Output 10 (MO8)	38: Error output selection 4 (Pr.06-26)		<input type="radio"/>	<input type="radio"/>	<input type="radio"/>	<input type="radio"/>	<input type="radio"/>
↗02-41	Multi-function Output 11 (MO9)	39: Position attained (Pr.10-19)					<input type="radio"/>	
↗02-42	Multi-function Output 12 (MOA)	40: Speed attained (including zero speed)		<input type="radio"/>	<input type="radio"/>	<input type="radio"/>	<input type="radio"/>	
		41: Multi-position attained					<input type="radio"/>	
		42: Crane function		<input type="radio"/>	<input type="radio"/>	<input type="radio"/>	<input type="radio"/>	

Group 3 Analog Input/Output Parameters

In version 2.02, the parameters are from Pr.03-00 to Pr.03-20. The settings for Pr.03-00 to Pr.03-02 are from 0 to 10

Pr.	Explanation	Settings	Factory Setting	VF	VFPG	SVC	FOCPG	TQCPG
↗03-00	Analog Input 1 (AVI)	2: torque command (torque limit under speed mode)	0					<input type="radio"/>
		3: Torque compensation command		<input type="radio"/>	<input type="radio"/>	<input type="radio"/>	<input type="radio"/>	<input type="radio"/>
		4: PID target value (refer to group 8)		<input type="radio"/>	<input type="radio"/>	<input type="radio"/>	<input type="radio"/>	
↗03-01	Analog Input 2 (ACI)	5: PID feedback signal (refer to group 8)		<input type="radio"/>	<input type="radio"/>	<input type="radio"/>	<input type="radio"/>	
		6: P.T.C. thermistor input value		<input type="radio"/>	<input type="radio"/>	<input type="radio"/>	<input type="radio"/>	<input type="radio"/>
↗03-02	Analog Input 3 (AUI)	7: Positive torque limit						<input type="radio"/>
		8: Negative torque limit					<input type="radio"/>	
		9: Regenerative torque limit					<input type="radio"/>	
		10: Positive/negative torque limit					<input type="radio"/>	
↗03-20	Analog Output Value in REV Direction	0: Absolute value in REV direction 1: Output 0V in REV direction 2: Enable output voltage in REV direction		0	<input type="radio"/>	<input type="radio"/>	<input type="radio"/>	<input type="radio"/>

Group 6 Protection Parameters

In version 2.02, the parameters are from Pr.06-00 to Pr.06-31. The settings of Pr.06-01 are shown as follows. The settings for Pr.06-17 to Pr.06-22 are from 0 to 62.

Pr.	Explanation	Settings	Factory Setting	VF	VFPG	SVC	FOCPG	TQCPG
↗06-01	Over-voltage Stall Prevention	0.0: Disable						
		350.0~450.0Vdc	380.0	<input type="radio"/>	<input type="radio"/>	<input type="radio"/>	<input type="radio"/>	<input type="radio"/>
		700.0~900.0Vdc	760.0	<input type="radio"/>	<input type="radio"/>	<input type="radio"/>	<input type="radio"/>	<input type="radio"/>
06-17	Present Fault Record	0: No fault	0	<input type="radio"/>	<input type="radio"/>	<input type="radio"/>	<input type="radio"/>	<input type="radio"/>
06-18	Second Most Recent Fault Record	1: Over-current during acceleration (ocA)	0	<input type="radio"/>	<input type="radio"/>	<input type="radio"/>	<input type="radio"/>	<input type="radio"/>
06-19	Third Most Recent Fault Record	2: Over-current during deceleration (ocd)	0	<input type="radio"/>	<input type="radio"/>	<input type="radio"/>	<input type="radio"/>	<input type="radio"/>
06-20	Fourth Most Recent Fault Record	3: Over-current during constant speed (ocn)	0	<input type="radio"/>	<input type="radio"/>	<input type="radio"/>	<input type="radio"/>	<input type="radio"/>
06-21	Fifth Most Recent Fault Record	4: Ground fault (GFF)	0	<input type="radio"/>	<input type="radio"/>	<input type="radio"/>	<input type="radio"/>	<input type="radio"/>
06-22	Sixth Most Recent Fault Record	5: IGBT short-circuit (occ)						
		6: Over-current at stop (ocS)						
		7: Over-voltage during acceleration (ovA)						
		8: Over-voltage during deceleration (ovd)						
		9: Over-voltage during constant speed (ovn)						
		10: Over-voltage at stop (ovS)						
		11: Low-voltage during acceleration (LvA)						
		12: Low-voltage during deceleration (Lvd)						
		13: Low-voltage during constant speed (Lvn)						
		14: Low-voltage at stop (LvS)						
		15: Phase loss (PHL)						
		16: IGBT heat sink over-heat (oH1)						

Pr.	Explanation	Settings	Factory Setting	VF	VFPG	SVC	FOCPG	TQCPG
		17: Heat sink over-heat (oH2)(for 40HP above) 18: TH1 open loop error (tH1o) 19: TH2 open loop error (tH2o) 20: Fan error signal output 21: over-load (oL) (150% 1Min) 22: Motor 1 over-load (EoL1) 23: Motor 2 over-load (EoL2) 24: Motor PTC overheat (oH3) 25: Fuse error (FuSE) 26: over-torque 1 (ot1) 27: over-torque 1 (ot2) 28: Insufficient torque 1 29: Insufficient torque 2 30: Memory write-in error (cF1) 31: Memory read-out error (cF2) 32: Isum current detection error (cd0) 33: U-phase current detection error (cd1) 34: V-phase current detection error (cd2) 35: W-phase current detection error (cd3) 36: Clamp current detection error (Hd0) 37: Over-current detection error (Hd1) 38: Over-voltage detection error (Hd2) 39: Ground current detection error (Hd3) 40: Auto tuning error (AuE) 41: PID feedback loss (AFE) 42: PG feedback error (PGF1) 43: PG feedback loss (PGF2) 44: PG feedback stall (PGF3) 45: PG slip error (PGF4) 46: PG ref input error (PGr1) 47: PG ref loss (PGr2) 48: Analog current input loss (ACE) 49: External fault input (EF) 50: Emergency stop (EF1) 51: External Base Block (B.B.) 52: Password error (PcodE) 53: Software error (ccodE) 54: Communication error (cE1) 55: Communication error (cE2) 56: Communication error (cE3) 57: Communication error (cE4) 58: Communication Time-out (cE10) 59: PU time-out (cP10) 60: Brake transistor error (bF) 61: Y-connection/Δ-connection switch error (ydc) 62: Decel. Energy Backup Error (dEb)						
∞06-31	Filter Time for PTC Detection	0.00~10.00sec	0.20	○	○	○	○	○

Group 8 High-function PID Parameters

In version 2.02, the parameters are from Pr.08-00 to Pr.08-15.

Pr.	Explanation	Settings	Factory Setting	VF	VFPG	SVC	FOCPG	TQCPG
∞08-15	Filter Time for PID Feedback	0.1~300.0 sec	5.0	○	○	○	○	○

Group 10 Speed Feedback Control Parameters

In version 2.02, the parameters are from Pr.10-00 to Pr.10-28.

Pr.	Explanation	Settings	Factory Setting	VF	VFPG	SVC	FOCPG	TQCPG
∞10-28	PG Mechanical Gear B1	1~5000	100		○		○	○

Group 11 Advanced Parameters

In version 2.02, the parameters are from Pr.11-00 to Pr.11-30.

Pr.	Explanation	Settings	Factory Setting	VF	VFPG	SVC	FOCPG	TQCPG
✓11-09	Level of Phase-loss	0.0~320.0	60.0	<input type="radio"/>	<input type="radio"/>	<input type="radio"/>	<input type="radio"/>	<input type="radio"/>
11-10	Reserved							
11-18 11-28	Reserved							
11-29	Accumulative Operation Time of Phase-loss	0~65535 (hour)	0	<input type="radio"/>	<input type="radio"/>	<input type="radio"/>	<input type="radio"/>	<input type="radio"/>
✓11-30	APR Curve Time	0.00~655.35 sec	3.00				<input type="radio"/>	

4.2.2 Version 2.04

New or update parameter groups are:

Group 0 System Parameters

Group 2: Digital Input/Output Parameters

Group 3: Analog Input/Output Parameters

Group 5: Motor Parameters

Group 6: Protection Parameters

Group 8: High-function PID Parameters

Group 10: Speed Feedback Control Parameters

Version 2.04

Group 0 System Parameters

Pr.	Explanation	Settings	Factory Setting	VF	VFPG	SVC	FOCPG	TQCPG
✓00-03	Start-up Display Selection	0: Display the frequency command value (LED F) 1: Display the actual output frequency (LED H) 2: Multifunction display, see Pr.00-04 (LED U) 3: Display the output current (A)	0	<input type="radio"/>	<input type="radio"/>	<input type="radio"/>	<input type="radio"/>	<input type="radio"/>
✓00-04	Content of Multi Function Display	0: Display output current (A) 1: Display counter value (C) 2: Display output frequency (H) 3: Display DC-BUS voltage (u) 4: Display output voltage (E) 5: Output power factor angle (n) 6: Display output power (kW) 7: Display actual motor speed (HU) 8: Display estimate output torque (kg-m) 9: Display PG position (G) (refer to Pr.10-00 and Pr.10-01) 10: Display PID feedback 11: Display AVI (%) 12: Display ACI (%) 13: Display AUI (%) 14: Display the temperature of heat sink (°C) 15: Display the temperature of IGBT (°C) 16: The status of digital input (ON/OFF) 17: The status of digital output (ON/OFF) 18: Multi-step speed 19: The corresponding CPU pin status of digital input 20: The corresponding CPU pin status of digital output 21: Number of actual motor revolution (PG1 of PG card) 22: Pulse input frequency (PG2 of PG card) 23: Pulse input position (PG2 of PG card)	0	<input type="radio"/>	<input type="radio"/>	<input type="radio"/>	<input type="radio"/>	<input type="radio"/>

Group 2 Digital Input/Output Parameters

New settings 44~50 for Pr.02-00~Pr.02-06 and new parameter 02-43.

Chapter 4 Parameters | VFD-VE

Pr.	Explanation	Settings	Factory Setting	VF	VFG	SVC	FOCPG	TOCPG
02-00	2-wire/3-wire Operation Control	0: FWD/STOP, REV/STOP 1: FWD/STOP, REV/STOP (Line Start Lockout) 2: RUN/STOP, REV/FWD 3: RUN/STOP, REV/FWD (Line Start Lockout) 4: 3-wire (momentary push button) 5: 3-wire (momentary push button and Line Start Lockout)	0	<input type="radio"/>	<input type="radio"/>	<input type="radio"/>	<input type="radio"/>	<input type="radio"/>
02-01	Multi-Function Input Command 1 (MI1) (It is Stop terminal for 3-wire operation)	0: no function 1: multi-step speed command 1/multi-step position command 1 2: multi-step speed command 2/ multi-step position command 2	1	<input type="radio"/>	<input type="radio"/>	<input type="radio"/>	<input type="radio"/>	<input type="radio"/>
02-02	Multi-Function Input Command 2 (MI2)	3: multi-step speed command 3/ multi-step position command 3 4: multi-step speed command 4/ multi-step position command 4	2	<input type="radio"/>	<input type="radio"/>	<input type="radio"/>	<input type="radio"/>	<input type="radio"/>
02-03	Multi-Function Input Command 3 (MI3)	5: Reset 6: JOG command	3	<input type="radio"/>	<input type="radio"/>	<input type="radio"/>	<input type="radio"/>	<input type="radio"/>
02-04	Multi-Function Input Command 4 (MI4)	7: acceleration/deceleration speed inhibit 8: the 1st, 2nd acceleration/deceleration time selection	4	<input type="radio"/>	<input type="radio"/>	<input type="radio"/>	<input type="radio"/>	<input type="radio"/>
02-05	Multi-Function Input Command 5 (MI5)	9: the 3rd, 4th acceleration/deceleration time selection 10: EF input (07-36)	0	<input type="radio"/>	<input type="radio"/>	<input type="radio"/>	<input type="radio"/>	<input type="radio"/>
02-06	Multi-Function Input Command 6 (MI6) (specific terminal for TRG)	11: B.B. input 12: Output stop	0	<input type="radio"/>	<input type="radio"/>	<input type="radio"/>	<input type="radio"/>	<input type="radio"/>
02-23	Multi-Function Input Command 7	13: cancel the setting of the optimal acceleration/deceleration time	0	<input type="radio"/>	<input type="radio"/>	<input type="radio"/>	<input type="radio"/>	<input type="radio"/>
02-24	Multi-Function Input Command 8	14: switch between drive settings 1 and 2	0	<input type="radio"/>	<input type="radio"/>	<input type="radio"/>	<input type="radio"/>	<input type="radio"/>
02-25	Multi-Function Input Command 9	15: operation speed command form AVI	0	<input type="radio"/>	<input type="radio"/>	<input type="radio"/>	<input type="radio"/>	<input type="radio"/>
02-26	Multi-Function Input Command 10	16: operation speed command form ACI	0	<input type="radio"/>	<input type="radio"/>	<input type="radio"/>	<input type="radio"/>	<input type="radio"/>
02-27	Multi-Function Input Command 11	17: operation speed command form AUI	0	<input type="radio"/>	<input type="radio"/>	<input type="radio"/>	<input type="radio"/>	<input type="radio"/>
02-28	Multi-Function Input Command 12	18: Emergency Stop (07-36)	0	<input type="radio"/>	<input type="radio"/>	<input type="radio"/>	<input type="radio"/>	<input type="radio"/>
02-29	Multi-Function Input Command 13	19: Digital Up command	0	<input type="radio"/>	<input type="radio"/>	<input type="radio"/>	<input type="radio"/>	<input type="radio"/>
02-30	Multi-Function Input Command 14	20: Digital Down command	0	<input type="radio"/>	<input type="radio"/>	<input type="radio"/>	<input type="radio"/>	<input type="radio"/>
		21: PID function disabled		<input type="radio"/>	<input type="radio"/>	<input type="radio"/>	<input type="radio"/>	<input type="radio"/>
		22: clear counter		<input type="radio"/>	<input type="radio"/>	<input type="radio"/>	<input type="radio"/>	<input type="radio"/>
		23: input the counter value (multi-function input command 6)		<input type="radio"/>	<input type="radio"/>	<input type="radio"/>	<input type="radio"/>	<input type="radio"/>
		24: FWD JOG command		<input type="radio"/>	<input type="radio"/>	<input type="radio"/>	<input type="radio"/>	<input type="radio"/>
		25: REV JOG command		<input type="radio"/>	<input type="radio"/>	<input type="radio"/>	<input type="radio"/>	<input type="radio"/>
		26: TQC+PG/FOC+PG model selection		<input type="radio"/>	<input type="radio"/>	<input type="radio"/>	<input type="radio"/>	<input type="radio"/>
		27: ASR1/ASR2 selection		<input type="radio"/>	<input type="radio"/>	<input type="radio"/>	<input type="radio"/>	<input type="radio"/>
		28: Emergency stop (EF1)		<input type="radio"/>	<input type="radio"/>	<input type="radio"/>	<input type="radio"/>	<input type="radio"/>
		29: Signal confirmation for Y-connection		<input type="radio"/>	<input type="radio"/>	<input type="radio"/>	<input type="radio"/>	<input type="radio"/>
		30: Signal confirmation for Δ-connection		<input type="radio"/>	<input type="radio"/>	<input type="radio"/>	<input type="radio"/>	<input type="radio"/>
		31: High torque bias (by Pr.07-29)		<input type="radio"/>	<input type="radio"/>	<input type="radio"/>	<input type="radio"/>	<input type="radio"/>
		32: Middle torque bias (by Pr.07-30)		<input type="radio"/>	<input type="radio"/>	<input type="radio"/>	<input type="radio"/>	<input type="radio"/>
		33: Low torque bias (by Pr.07-31)		<input type="radio"/>	<input type="radio"/>	<input type="radio"/>	<input type="radio"/>	<input type="radio"/>
		34: Enable multi-step position control		<input type="radio"/>	<input type="radio"/>	<input type="radio"/>	<input type="radio"/>	<input type="radio"/>
		35: Enable position control		<input type="radio"/>	<input type="radio"/>	<input type="radio"/>	<input type="radio"/>	<input type="radio"/>
		36: Enable position learning function (valid at stop)		<input type="radio"/>	<input type="radio"/>	<input type="radio"/>	<input type="radio"/>	<input type="radio"/>
		37: Enable pulse position input command		<input type="radio"/>	<input type="radio"/>	<input type="radio"/>	<input type="radio"/>	<input type="radio"/>
		38: Disable write EEPROM function		<input type="radio"/>	<input type="radio"/>	<input type="radio"/>	<input type="radio"/>	<input type="radio"/>
		39: Torque command direction		<input type="radio"/>	<input type="radio"/>	<input type="radio"/>	<input type="radio"/>	<input type="radio"/>
		40: Force stop		<input type="radio"/>	<input type="radio"/>	<input type="radio"/>	<input type="radio"/>	<input type="radio"/>
		41: Serial position clock		<input type="radio"/>	<input type="radio"/>	<input type="radio"/>	<input type="radio"/>	<input type="radio"/>
		42: Serial position input		<input type="radio"/>	<input type="radio"/>	<input type="radio"/>	<input type="radio"/>	<input type="radio"/>
		43: Analog input resolution selection		<input type="radio"/>	<input type="radio"/>	<input type="radio"/>	<input type="radio"/>	<input type="radio"/>
		44: Reset initial reel diameter		<input type="radio"/>	<input type="radio"/>	<input type="radio"/>	<input type="radio"/>	<input type="radio"/>

Pr.	Explanation	Settings	Factory Setting	VF	VFP	SVC	FOCPG	TQCPG
		45: Reset initial reel diameter 0		<input type="checkbox"/>	<input type="checkbox"/>	<input type="checkbox"/>	<input type="checkbox"/>	<input type="checkbox"/>
		46: Reset initial reel diameter 1		<input type="checkbox"/>	<input type="checkbox"/>	<input type="checkbox"/>	<input type="checkbox"/>	<input type="checkbox"/>
		47: Reset PID control integration of tension		<input type="checkbox"/>	<input type="checkbox"/>	<input type="checkbox"/>	<input type="checkbox"/>	<input type="checkbox"/>
		48: Mechanical gear ratio switch		<input type="checkbox"/>	<input type="checkbox"/>	<input type="checkbox"/>	<input type="checkbox"/>	<input type="checkbox"/>
		49: Reserved						
		50: Reserved						
↗02-11	Multi-function Output 1 RA, RB, RC(Relay1)	0: No function 1: Operation indication	11	<input type="checkbox"/>	<input type="checkbox"/>	<input type="checkbox"/>	<input type="checkbox"/>	<input type="checkbox"/>
↗02-12	Multi-function Output 2 MRA, MRC (Relay2)	2: Operation speed attained 3: Desired frequency attained 1 (Pr.02-19)	1	<input type="checkbox"/>	<input type="checkbox"/>	<input type="checkbox"/>	<input type="checkbox"/>	<input type="checkbox"/>
↗02-13	Multi-function Output 3 (MO1)	4: Desired frequency attained 2 (Pr.02-21) 5: Zero speed (frequency command) 6: Zero speed with stop (frequency command) 7: Over torque (OT1) (Pr.06-06-06-08) 8: Over torque (OT2) (Pr.06-09-06-11)	0	<input type="checkbox"/>	<input type="checkbox"/>	<input type="checkbox"/>	<input type="checkbox"/>	<input type="checkbox"/>
↗02-14	Multi-function Output 4 (MO2)	9: Drive ready 10: User-defined Low-voltage Detection 11: Malfunction indication	0	<input type="checkbox"/>	<input type="checkbox"/>	<input type="checkbox"/>	<input type="checkbox"/>	<input type="checkbox"/>
↗02-35	Multi-function Output 5 (MO3)	12: Mechanical brake release (Pr.02-31) 13: Overheat 14: Software brake signal		<input type="checkbox"/>	<input type="checkbox"/>	<input type="checkbox"/>	<input type="checkbox"/>	<input type="checkbox"/>
↗02-36	Multi-function Output 6 (MO4)	15: PID feedback error 16: Slip error (oSL) 17: Terminal count value attained (Pr.02-16)		<input type="checkbox"/>	<input type="checkbox"/>	<input type="checkbox"/>	<input type="checkbox"/>	<input type="checkbox"/>
↗02-37	Multi-function Output 7 (MO5)	18: Preliminary count value attained (Pr.02-17) 19: Baseblock (B.B.) Indication 20: Warning output		<input type="checkbox"/>	<input type="checkbox"/>	<input type="checkbox"/>	<input type="checkbox"/>	<input type="checkbox"/>
↗02-38	Multi-function Output 8 (MO6)	21: Over voltage warning 22: Over-current stall prevention warning 23: Over-voltage stall prevention warning		<input type="checkbox"/>	<input type="checkbox"/>	<input type="checkbox"/>	<input type="checkbox"/>	<input type="checkbox"/>
↗02-39	Multi-function Output 9 (MO7)	24: Operation mode indication 25: Forward command 26: Reverse command		<input type="checkbox"/>	<input type="checkbox"/>	<input type="checkbox"/>	<input type="checkbox"/>	<input type="checkbox"/>
↗02-40	Multi-function Output 10 (MO8)	27: Output when current >= Pr.02-32 28: Output when current < Pr.02-32 29: Output when frequency >= Pr.02-33		<input type="checkbox"/>	<input type="checkbox"/>	<input type="checkbox"/>	<input type="checkbox"/>	<input type="checkbox"/>
↗02-41	Multi-function Output 11 (MO9)	30: Output when frequency < Pr.02-33 31: Y-connection for the motor coil 32: Δ connection for the motor coil		<input type="checkbox"/>	<input type="checkbox"/>	<input type="checkbox"/>	<input type="checkbox"/>	<input type="checkbox"/>
↗02-42	Multi-function Output 12 (MOA)	33: Zero speed (actual output frequency) 34: Zero speed with Stop (actual output frequency) 35: Error output selection 1 (Pr.06-23) 36: Error output selection 2 (Pr.06-24) 37: Error output selection 3 (Pr.06-25) 38: Error output selection 4 (Pr.06-26) 39: Position attained (Pr.10-19) 40: Speed attained (including zero speed) 41: Multi-position attained 42: Crane function 43: Motor zero-speed output (Pr.02-43) 44: Max. reel diameter attained 45: Empty reel diameter attained 46: Broken belt detection 47: Break release at stop 48: Error PID feedback of tension 49: Reserved 50: Reserved		<input type="checkbox"/>	<input type="checkbox"/>	<input type="checkbox"/>	<input type="checkbox"/>	<input type="checkbox"/>

Chapter 4 Parameters | VFD-VE

Pr.	Explanation	Settings	Factory Setting	VF	VFPG	SVC	FOCPG	TOCPG
∕02-43	Zero-speed Level of Motor	0-65535 rpm	0	<input type="radio"/>	<input type="radio"/>	<input type="radio"/>	<input type="radio"/>	<input type="radio"/>

Group 3 Analog Input/Output Parameters
New settings 11-16 for Pr.03-00-Pr.03-02 and new parameters 03-21-03-26.

Pr.	Explanation	Settings	Factory Setting	VF	VFPG	SVC	FOCPG	TOCPG
∕03-00	Analog Input 1 (AVI)	0: No function	1	<input type="radio"/>	<input type="radio"/>	<input type="radio"/>	<input type="radio"/>	<input type="radio"/>
∕03-01	Analog Input 2 (ACI)	1: Frequency command (torque limit under TQR control mode)	0	<input type="radio"/>	<input type="radio"/>	<input type="radio"/>	<input type="radio"/>	<input type="radio"/>
∕03-02	Analog Input 3 (AUI)	2: torque command (torque limit under speed mode)	0	<input type="radio"/>	<input type="radio"/>	<input type="radio"/>	<input type="radio"/>	<input type="radio"/>
		3: Torque compensation command		<input type="radio"/>	<input type="radio"/>	<input type="radio"/>	<input type="radio"/>	<input type="radio"/>
		4: PID target value (refer to group 8)		<input type="radio"/>	<input type="radio"/>	<input type="radio"/>	<input type="radio"/>	<input type="radio"/>
		5: PID feedback signal (refer to group 8)		<input type="radio"/>	<input type="radio"/>	<input type="radio"/>	<input type="radio"/>	<input type="radio"/>
		6: P.T.C. thermistor input value		<input type="radio"/>	<input type="radio"/>	<input type="radio"/>	<input type="radio"/>	<input type="radio"/>
		7: Positive torque limit		<input type="radio"/>	<input type="radio"/>	<input type="radio"/>	<input type="radio"/>	<input type="radio"/>
		8: Negative torque limit		<input type="radio"/>	<input type="radio"/>	<input type="radio"/>	<input type="radio"/>	<input type="radio"/>
		9: Regenerative torque limit		<input type="radio"/>	<input type="radio"/>	<input type="radio"/>	<input type="radio"/>	<input type="radio"/>
		10: Positive/negative torque limit		<input type="radio"/>	<input type="radio"/>	<input type="radio"/>	<input type="radio"/>	<input type="radio"/>
		11: PID feedback signal of tension		<input type="radio"/>	<input type="radio"/>	<input type="radio"/>	<input type="radio"/>	<input type="radio"/>
		12: Line speed		<input type="radio"/>	<input type="radio"/>	<input type="radio"/>	<input type="radio"/>	<input type="radio"/>
		13: Reel diameter		<input type="radio"/>	<input type="radio"/>	<input type="radio"/>	<input type="radio"/>	<input type="radio"/>
		14: PID target value of tension (tension closed-loop)		<input type="radio"/>	<input type="radio"/>	<input type="radio"/>	<input type="radio"/>	<input type="radio"/>
		15: Tension setting (tension open-loop)		<input type="radio"/>	<input type="radio"/>	<input type="radio"/>	<input type="radio"/>	<input type="radio"/>
		16: Zero-speed tension		<input type="radio"/>	<input type="radio"/>	<input type="radio"/>	<input type="radio"/>	<input type="radio"/>
		17: Tension taper		<input type="radio"/>	<input type="radio"/>	<input type="radio"/>	<input type="radio"/>	<input type="radio"/>
		∕03-18		Analog Output Selection	0: Output frequency (Hz)	0	<input type="radio"/>	<input type="radio"/>
1: Frequency command (Hz)	<input type="radio"/>		<input type="radio"/>		<input type="radio"/>		<input type="radio"/>	<input type="radio"/>
∕03-21	Analog Output Selection 2	2: Motor speed (Hz)	0	<input type="radio"/>	<input type="radio"/>	<input type="radio"/>	<input type="radio"/>	<input type="radio"/>
		3: Output current (rms)		<input type="radio"/>	<input type="radio"/>	<input type="radio"/>	<input type="radio"/>	<input type="radio"/>
		4: Output voltage		<input type="radio"/>	<input type="radio"/>	<input type="radio"/>	<input type="radio"/>	<input type="radio"/>
∕03-24	Analog Output Selection 3	5: DC Bus Voltage	0	<input type="radio"/>	<input type="radio"/>	<input type="radio"/>	<input type="radio"/>	<input type="radio"/>
		6: Power factor		<input type="radio"/>	<input type="radio"/>	<input type="radio"/>	<input type="radio"/>	<input type="radio"/>
		7: Power		<input type="radio"/>	<input type="radio"/>	<input type="radio"/>	<input type="radio"/>	<input type="radio"/>
		8: Output torque		<input type="radio"/>	<input type="radio"/>	<input type="radio"/>	<input type="radio"/>	<input type="radio"/>
		9: AVI		<input type="radio"/>	<input type="radio"/>	<input type="radio"/>	<input type="radio"/>	<input type="radio"/>
		10: ACI		<input type="radio"/>	<input type="radio"/>	<input type="radio"/>	<input type="radio"/>	<input type="radio"/>
		11: AUI		<input type="radio"/>	<input type="radio"/>	<input type="radio"/>	<input type="radio"/>	<input type="radio"/>
		12: q-axis current		<input type="radio"/>	<input type="radio"/>	<input type="radio"/>	<input type="radio"/>	<input type="radio"/>
		13: q-axis feedback value		<input type="radio"/>	<input type="radio"/>	<input type="radio"/>	<input type="radio"/>	<input type="radio"/>
		14: d-axis current		<input type="radio"/>	<input type="radio"/>	<input type="radio"/>	<input type="radio"/>	<input type="radio"/>
		15: d-axis feedback value		<input type="radio"/>	<input type="radio"/>	<input type="radio"/>	<input type="radio"/>	<input type="radio"/>
		16: q-axis voltage		<input type="radio"/>	<input type="radio"/>	<input type="radio"/>	<input type="radio"/>	<input type="radio"/>
		17: d-axis voltage		<input type="radio"/>	<input type="radio"/>	<input type="radio"/>	<input type="radio"/>	<input type="radio"/>
		18: Torque command		<input type="radio"/>	<input type="radio"/>	<input type="radio"/>	<input type="radio"/>	<input type="radio"/>
		19: Pulse frequency command		<input type="radio"/>	<input type="radio"/>	<input type="radio"/>	<input type="radio"/>	<input type="radio"/>
∕03-22	Analog Output Gain 2	0-200.0%	100.0	<input type="radio"/>	<input type="radio"/>	<input type="radio"/>	<input type="radio"/>	<input type="radio"/>
∕03-23	Analog Output Value in REV Direction 2	0: Absolute value in REV direction	0	<input type="radio"/>	<input type="radio"/>	<input type="radio"/>	<input type="radio"/>	<input type="radio"/>
		1: Output 0V in REV direction		<input type="radio"/>	<input type="radio"/>	<input type="radio"/>	<input type="radio"/>	<input type="radio"/>
		2: Enable output voltage in REV direction		<input type="radio"/>	<input type="radio"/>	<input type="radio"/>	<input type="radio"/>	<input type="radio"/>
∕03-25	Analog Output Gain 3	0-200.0%	100.0	<input type="radio"/>	<input type="radio"/>	<input type="radio"/>	<input type="radio"/>	<input type="radio"/>
∕03-26	Analog Output Value in REV Direction 3	0: Absolute value in REV direction	0	<input type="radio"/>	<input type="radio"/>	<input type="radio"/>	<input type="radio"/>	<input type="radio"/>
		1: Output 0V in REV direction		<input type="radio"/>	<input type="radio"/>	<input type="radio"/>	<input type="radio"/>	<input type="radio"/>
		2: Enable output voltage in REV direction		<input type="radio"/>	<input type="radio"/>	<input type="radio"/>	<input type="radio"/>	<input type="radio"/>

Group 5 Motor Parameters

Pr.	Explanation	Settings	Factory Setting	VF	VFPG	SVC	FOCPG	TQCPG
05-00	Motor Auto Tuning	0: No function 1: Rolling test 2: Static Test 3: Reserved	0			○	○	○
05-01	Full-load Current of Motor 1	40-100%	###	○	○	○	○	○
05-02	Rated power of Motor 1	0-655.35	###			○	○	○
05-03	Rated speed of Motor 1 (rpm)	0-65535 1710 (60Hz, 4 poles), 1410 (50Hz, 4 poles)	1710		○	○	○	○

Group 6 Protection Parameters

New setting 0 for Pr.06-01, new settings 64-65 for Pr.06-17-Pr.06-22 and new parameters 06-32-06-36.

Pr.	Explanation	Settings	Factory Setting	VF	VFPG	SVC	FOCPG	TQCPG
06-01	Over-voltage Stall Prevention	0.0: Disable						
		350.0-450.0Vdc	380.0	○	○	○	○	○
		700.0-900.0Vdc	760.0	○	○	○	○	○
06-17	Present Fault Record	0: No fault	0	○	○	○	○	○
		1: Over-current during acceleration (oCa)		○	○	○	○	○
06-18	Second Most Recent Fault Record	2: Over-current during deceleration (ocd)	0	○	○	○	○	○
		3: Over-current during constant speed (ocn)		○	○	○	○	○
		4: Ground fault (GFF)		○	○	○	○	○
06-19	Third Most Recent Fault Record	5: IGBT short-circuit (occ)	0	○	○	○	○	○
		6: Over-current at stop (ocS)		○	○	○	○	○
		7: Over-voltage during acceleration (ovA)		○	○	○	○	○
		8: Over-voltage during deceleration (ovd)	0	○	○	○	○	○
06-20	Fourth Most Recent Fault Record	9: Over-voltage during constant speed (ovn)		○	○	○	○	○
		10: Over-voltage at stop (ovS)		○	○	○	○	○
		11: Low-voltage during acceleration (LvA)		○	○	○	○	○
		12: Low-voltage during deceleration (Lvd)	0	○	○	○	○	○
06-21	Fifth Most Recent Fault Record	13: Low-voltage during constant speed (Lvn)		○	○	○	○	○
		14: Low-voltage at stop (LvS)	0	○	○	○	○	○
		15: Phase loss (PHL)		○	○	○	○	○
		16: IGBT heat sink over-heat (oH1)		○	○	○	○	○
		17: Heat sink over-heat (oH2)(for 40HP above)	0	○	○	○	○	○
06-22	Sixth Most Recent Fault Record	18: TH1 open loop error (tH1o)		○	○	○	○	○
		19: TH2 open loop error (tH2o)		○	○	○	○	○
		20: Fan error signal output		○	○	○	○	○
		21: over-load (oL) (150% 1Min)		○	○	○	○	○
		22: Motor 1 over-load (EoL1)		○	○	○	○	○
		23: Motor 2 over-load (EoL2)		○	○	○	○	○
		24: Motor PTC overheat (oH3)		○	○	○	○	○
		25: Fuse error (FuSE)		○	○	○	○	○
		26: over-torque 1 (ot1)		○	○	○	○	○
		27: over-torque 1 (ot2)		○	○	○	○	○
		28: Reserved		○	○	○	○	○
		29: Reserved		○	○	○	○	○
		30: Memory write-in error (cF1)		○	○	○	○	○
		31: Memory read-out error (cF2)		○	○	○	○	○
		32: Isum current detection error (cd0)		○	○	○	○	○
33: U-phase current detection error (cd1)		○	○	○	○	○		
34: V-phase current detection error (cd2)		○	○	○	○	○		
35: W-phase current detection error (cd3)		○	○	○	○	○		
36: Clamp current detection error (Hd0)		○	○	○	○	○		
37: Over-current detection error (Hd1)		○	○	○	○	○		
38: Over-voltage detection error (Hd2)		○	○	○	○	○		
39: Ground current detection error (Hd3)		○	○	○	○	○		
40: Auto tuning error (AuE)		○	○	○	○	○		
41: PID feedback loss (AFE)		○	○	○	○	○		

Chapter 4 Parameters | VFD-VE

Pr.	Explanation	Settings	Factory Setting	VF	VFPG	SVC	FOCPG	TQCPG
		42: PG feedback error (PGF1)		<input type="checkbox"/>	<input type="checkbox"/>	<input type="checkbox"/>	<input type="checkbox"/>	<input type="checkbox"/>
		43: PG feedback loss (PGF2)		<input type="checkbox"/>	<input type="checkbox"/>	<input type="checkbox"/>	<input type="checkbox"/>	<input type="checkbox"/>
		44: PG feedback stall (PGF3)		<input type="checkbox"/>	<input type="checkbox"/>	<input type="checkbox"/>	<input type="checkbox"/>	<input type="checkbox"/>
		45: PG slip error (PGF4)		<input type="checkbox"/>	<input type="checkbox"/>	<input type="checkbox"/>	<input type="checkbox"/>	<input type="checkbox"/>
		46: PG ref input error (PGr1)		<input type="checkbox"/>	<input type="checkbox"/>	<input type="checkbox"/>	<input type="checkbox"/>	<input type="checkbox"/>
		47: PG ref loss (PGr2)		<input type="checkbox"/>	<input type="checkbox"/>	<input type="checkbox"/>	<input type="checkbox"/>	<input type="checkbox"/>
		48: Analog current input loss (ACE)		<input type="checkbox"/>	<input type="checkbox"/>	<input type="checkbox"/>	<input type="checkbox"/>	<input type="checkbox"/>
		49: External fault input (EF)		<input type="checkbox"/>	<input type="checkbox"/>	<input type="checkbox"/>	<input type="checkbox"/>	<input type="checkbox"/>
		50: Emergency stop (EF1)		<input type="checkbox"/>	<input type="checkbox"/>	<input type="checkbox"/>	<input type="checkbox"/>	<input type="checkbox"/>
		51: External Base Block (B.B.)		<input type="checkbox"/>	<input type="checkbox"/>	<input type="checkbox"/>	<input type="checkbox"/>	<input type="checkbox"/>
		52: Password error (PcodE)		<input type="checkbox"/>	<input type="checkbox"/>	<input type="checkbox"/>	<input type="checkbox"/>	<input type="checkbox"/>
		53: Reserved		<input type="checkbox"/>	<input type="checkbox"/>	<input type="checkbox"/>	<input type="checkbox"/>	<input type="checkbox"/>
		54: Communication error (cE1)		<input type="checkbox"/>	<input type="checkbox"/>	<input type="checkbox"/>	<input type="checkbox"/>	<input type="checkbox"/>
		55: Communication error (cE2)		<input type="checkbox"/>	<input type="checkbox"/>	<input type="checkbox"/>	<input type="checkbox"/>	<input type="checkbox"/>
		56: Communication error (cE3)		<input type="checkbox"/>	<input type="checkbox"/>	<input type="checkbox"/>	<input type="checkbox"/>	<input type="checkbox"/>
		57: Communication error (cE4)		<input type="checkbox"/>	<input type="checkbox"/>	<input type="checkbox"/>	<input type="checkbox"/>	<input type="checkbox"/>
		58: Communication Time-out (cE10)		<input type="checkbox"/>	<input type="checkbox"/>	<input type="checkbox"/>	<input type="checkbox"/>	<input type="checkbox"/>
		59: PU time-out (cP10)		<input type="checkbox"/>	<input type="checkbox"/>	<input type="checkbox"/>	<input type="checkbox"/>	<input type="checkbox"/>
		60: Brake transistor error (bF)		<input type="checkbox"/>	<input type="checkbox"/>	<input type="checkbox"/>	<input type="checkbox"/>	<input type="checkbox"/>
		61: Y-connection/Δ-connection switch error (ydc)		<input type="checkbox"/>	<input type="checkbox"/>	<input type="checkbox"/>	<input type="checkbox"/>	<input type="checkbox"/>
		62: Decel. Energy Backup Error (dEb)		<input type="checkbox"/>	<input type="checkbox"/>	<input type="checkbox"/>	<input type="checkbox"/>	<input type="checkbox"/>
		63: Slip error (oS _L)		<input type="checkbox"/>	<input type="checkbox"/>	<input type="checkbox"/>	<input type="checkbox"/>	<input type="checkbox"/>
		64: Broken belt error (bEb)		<input type="checkbox"/>	<input type="checkbox"/>	<input type="checkbox"/>	<input type="checkbox"/>	<input type="checkbox"/>
		65: Error PID feedback signal of tension (tdEv)		<input type="checkbox"/>	<input type="checkbox"/>	<input type="checkbox"/>	<input type="checkbox"/>	<input type="checkbox"/>
06-32	Output Frequency for Malfunction	0.00~655.35 Hz	0.00	<input type="checkbox"/>	<input type="checkbox"/>	<input type="checkbox"/>	<input type="checkbox"/>	<input type="checkbox"/>
06-33	Output AC Voltage for Malfunction	0.0~6553.5 V	0.0	<input type="checkbox"/>	<input type="checkbox"/>	<input type="checkbox"/>	<input type="checkbox"/>	<input type="checkbox"/>
06-34	DC Voltage for Malfunction	0.0~6553.5 V	0.0	<input type="checkbox"/>	<input type="checkbox"/>	<input type="checkbox"/>	<input type="checkbox"/>	<input type="checkbox"/>
06-35	Current Value for Malfunction	0.00~655.35 Amp	0.00	<input type="checkbox"/>	<input type="checkbox"/>	<input type="checkbox"/>	<input type="checkbox"/>	<input type="checkbox"/>
06-36	IGBT Temperature for Malfunction	0.0~6553.5 °C	0.0	<input type="checkbox"/>	<input type="checkbox"/>	<input type="checkbox"/>	<input type="checkbox"/>	<input type="checkbox"/>

Group 8 High-function PID Parameters
New parameters 08-21~08-99

Pr.	Explanation	Settings	Factory Setting	VF	VFPG	SVC	FOCPG	TQCPG
↗08-00	Input Terminal for PID Feedback	0: No function 1: Negative PID feedback from external terminal AVI (Pr.03-00) 2: Negative PID feedback from PG card (Pr.10-15, skip direction) 3: Negative PID feedback from PG card (Pr.10-15) 4: Positive PID feedback from external terminal AVI (Pr.03-00) 5: Positive PID feedback from PG card (Pr.10-15, skip direction) 6: Positive PID feedback from PG card (Pr.10-15)	0	<input type="checkbox"/>	<input type="checkbox"/>	<input type="checkbox"/>	<input type="checkbox"/>	<input type="checkbox"/>
↗08-01	Proportional Gain (P)	0.0~500.0%	80.0	<input type="checkbox"/>	<input type="checkbox"/>	<input type="checkbox"/>	<input type="checkbox"/>	<input type="checkbox"/>
08-21	Tension Control Selection	0: Disable 1: Closed-loop, speed mode 2: Line speed, speed mode 3: Reserved 4: Open-loop, torque mode	0	<input type="checkbox"/>	<input type="checkbox"/>	<input type="checkbox"/>	<input type="checkbox"/>	<input type="checkbox"/>
08-22	Wind Mode	0: Rewind 1: Unwind	0	<input type="checkbox"/>	<input type="checkbox"/>	<input type="checkbox"/>	<input type="checkbox"/>	<input type="checkbox"/>
08-23	Mechanical Gear Ratio A	1-65535	100	<input type="checkbox"/>	<input type="checkbox"/>	<input type="checkbox"/>	<input type="checkbox"/>	<input type="checkbox"/>

Pr.	Explanation	Settings	Factory Setting	VF	VFPG	SVC	FOCPG	TCQPG
08-24	Mechanical Gear Ratio B	1-65535	100	○	○	○	○	○
08-25	Source of the Tension Command/Line Speed	0: Parameter setting (Pr.08-26) 1: RS-485 communication setting (Pr.08-26) 2: Analog input (Pr. 03-00-03-02 is set to 14 PID target value of tension, 03-00-03-02 is set to 12 line speed)	0	○	○	○	○	○
08-26	PID Target Value of Tension/Line Speed	0.0-100.0%	50.0	○	○	○	○	○
08-27	Source of Tension/Line Speed PID Feedback	0: Analog input (Pr. 03-00-03-02 is set to 11 PID feedback of tension) 1: Pulse input (Pr.08-40)	0	○	○	○	○	○
08-28	Auto-tuning Tension PID	0: Disable 1: Reel diameter (08-29-08-31 corresponds to 08-44, 08-32-08-34 corresponds to 08-43) 2: Frequency (08-29-08-31 corresponds to 01-07, 08-32-08-34 corresponds to 01-00)		○	○	○	○	○
08-29	Tension PID P1	0.0-1000.0	50.0	○	○	○	○	○
08-30	Tension PID I1	0.00-500.00 sec	1.00	○	○	○	○	○
08-31	Reserved							
08-32	Tension PID P2	0.0-1000.0	50.0	○	○	○	○	○
08-33	Tension PID I2	0.00-500.00 sec	1.00	○	○	○	○	○
08-34	Reserved							
08-35	PID/Line Speed Output Status	0: Positive output 1: Negative output	0	○	○	○	○	○
08-36	Tension/Line Speed PID Output Limit	0-100.00% (according to Pr.01-00)	20.00	○	○	○	○	○
08-37	Source of Line Speed Input Command	0: Disable 1: Analog input (Pr. 03-00-03-02 is set to 12 line speed) 2: RS-485 communication setting (Pr.08-41) 3: Pulse input (Pr.08-40) 4: DFM-DCM pulse input (Pr.02-18)	0	○	○	○	○	○
08-38	Max. Line Speed	0.0-3000.0m/min	1000.0	○	○	○	○	○
08-39	Min. Line Speed	0.0-3000.0m/min	0.0	○	○	○	○	○
08-40	Pulse Number for Each Meter	0.0-6000.0	0.0	○	○	○	○	○
08-41	Current Line Speed	0.0-3000.0m/min	0.0	○	○	○	○	○
08-42	Source of Reel Diameter	0: Calculated by line speed 1: Calculated by integrating thickness (encoder is on reel shaft)(Pr.08-49-51, Pr.10-15) 2: Calculated by integrating thickness (encoder is on motor)(Pr.08-23-08-24, 08-50-08-51, 10-00-10-01) 3: Calculated by analog input (Pr.03-00-03-02 is set to 13)	0	○	○	○	○	○
08-43	Max. Reel Diameter	1.0-6000.0mm	6000.0	○	○	○	○	○
08-44	Empty Reel Diameter	1.0-6000.0mm	1.0	○	○	○	○	○
08-45	Source of Initial Reel Diameter	0: RS-485 communication setting (Pr.08-46) 1: Analog input (Pr.03-00-Pr.03-02 is set to 13)	0	○	○	○	○	○
08-46	Initial Reel Diameter	1.0-6000.0mm	1.0	○	○	○	○	○
08-47	Initial Reel Diameter 1	1.0-6000.0mm	1.0	○	○	○	○	○
08-48	Initial Reel Diameter 2	1.0-6000.0mm	1.0	○	○	○	○	○
08-49	Number of Pulse per Revolution	1-10000ppr	1	○	○	○	○	○
08-50	Coil Number for Each Layer	0.001-60.000mm	1.000	○	○	○	○	○
08-51	Material Thickness	0.001-60.000mm	1.000	○	○	○	○	○
08-52	Filter Time of Reel Diameter	0.00 to 100.00 seconds	1.00	○	○	○	○	○
08-53	Auto Compensation of Reel Diameter	0: Disable 1: Enable	1.00	○	○	○	○	○
08-54	Current Reel Diameter	1.0-6000.0mm	1.0	○	○	○	○	○
08-55	Smart Start	0: Disable 1: Enable	1	○	○	○	○	○

Chapter 4 Parameters | VFD-VE

Pr.	Explanation	Settings	Factory Setting	VF	VFPG	SVC	FOCPG	TOCPG
		2: In unwind mode, rewind in reverse direction						
08-56	Switch Level for Smart Start and PID function	0.0~100.0% (according to Pr.08-26)	15.0	<input type="radio"/>	<input type="radio"/>	<input type="radio"/>	<input type="radio"/>	<input type="radio"/>
08-57	Frequency for Smart Start	0.00~600.00Hz	2.00	<input type="radio"/>	<input type="radio"/>	<input type="radio"/>	<input type="radio"/>	<input type="radio"/>
08-58	Accel. Time for Smart Start	0.01~600.00 seconds	3.00	<input type="radio"/>	<input type="radio"/>	<input type="radio"/>	<input type="radio"/>	<input type="radio"/>
08-59	Broken Belt Detection	0: Disable 1: Enable	0	<input type="radio"/>	<input type="radio"/>	<input type="radio"/>	<input type="radio"/>	<input type="radio"/>
08-60	Min. Line Speed of Broken Belt Detection	0.0~3000.0m/min	0.0	<input type="radio"/>	<input type="radio"/>	<input type="radio"/>	<input type="radio"/>	<input type="radio"/>
08-61	Allowance Error of Line Speed of Broken Belt Detection	1.0~6000.0mm	100.0	<input type="radio"/>	<input type="radio"/>	<input type="radio"/>	<input type="radio"/>	<input type="radio"/>
08-62	Detection Time of Broken Belt	0.00~100.00 sec	1.00	<input type="radio"/>	<input type="radio"/>	<input type="radio"/>	<input type="radio"/>	<input type="radio"/>
08-63	Allowance Error Level of Tension/Line Speed PID Feedback	0~100%	100	<input type="radio"/>	<input type="radio"/>	<input type="radio"/>	<input type="radio"/>	<input type="radio"/>
08-64	Allowance Error Detection Time of Tension PID Feedback	0.0~10.0 sec	0.5	<input type="radio"/>	<input type="radio"/>	<input type="radio"/>	<input type="radio"/>	<input type="radio"/>
08-65	Error Treatment of Tension PID Feedback	0: Warn and keep operation 1: Warn and coast to stop 2: Warn and ramp to stop	0	<input type="radio"/>	<input type="radio"/>	<input type="radio"/>	<input type="radio"/>	<input type="radio"/>
08-66	Upper Limit of Tension PID Feedback	0.0~100.0%	100.0	<input type="radio"/>	<input type="radio"/>	<input type="radio"/>	<input type="radio"/>	<input type="radio"/>
08-67	Lower Limit of Tension PID Feedback	0.0~100.0%	0.0	<input type="radio"/>	<input type="radio"/>	<input type="radio"/>	<input type="radio"/>	<input type="radio"/>
08-68	Reserved							
08-69	DFM Selection	0: Output frequency 1: Frequency command	0	<input type="radio"/>	<input type="radio"/>	<input type="radio"/>	<input type="radio"/>	<input type="radio"/>
08-70	Low-pass Filter Time of Line Speed	0.00~100.00 sec	0.00	<input type="radio"/>	<input type="radio"/>	<input type="radio"/>	<input type="radio"/>	<input type="radio"/>
08-71 08-75	Reserved							
08-76	Source of Tension Setting	0: Communication RS-485 (Pr.08-78) 1: Analog input (Pr. 03-00~03-02 is set to 15 tension setting) (Pr.08-78)	0					<input type="radio"/>
08-77	Max. Tension	0~30000 N	0					<input type="radio"/>
08-78	Tension Setting	0~30000 N	0					<input type="radio"/>
08-79	Source of Zero-speed Tension Setting	0: Disable 1: Communication RS-485 (Pr.08-80) 2: Analog input (Pr. 03-00~03-02 is set to 16 zero-speed tension) (Pr.08-80)	0					<input type="radio"/>
08-80	Setting of Zero-speed Tension	0~30000 N	0					<input type="radio"/>
08-81	Source of Tension Taper	0: Communication RS-485 (Pr.08-82) 1: Analog input (Pr. 03-00~03-02 is set to 17 tension taper)(Pr.08-82)	0					<input type="radio"/>
08-82	Tension Taper	0~100%	0					<input type="radio"/>
08-83	Friction Compensation	0.0~100.0%	0.0					<input type="radio"/>
08-84	Compensation Coefficient of Material Inertial	0~30000	0					<input type="radio"/>
08-85	Torque Feed Forward Gain	0.0~100.0%	50.0					<input type="radio"/>
08-86	Low Pass Filter Time of Torque Feed Forward	0.00~100.00	5.00					<input type="radio"/>
08-87 08-99	Reserved							

Group 9 Communication Parameters

Pr.	Explanation	Settings	Factory Setting	VF	VFP	SVC	FOCP	TQCP
✓09-21	Multi-function Output Status	0~65535	Read-only	○	○	○	○	○
✓09-22	AFM2 Status	0~4095	Read-only	○	○	○	○	○
✓09-23	AFM3 Status	0~4095	Read-only	○	○	○	○	○

Group 10 Speed Feedback Control Parameters

New parameters 10-29~10-30

Pr.	Explanation	Settings	Factory Setting	VF	VFP	SVC	FOCP	TQCP
✓10-04	ASR (Auto Speed Regulation) Control (P) 1	0~40	10		○		○	
✓10-06	ASR (Auto Speed Regulation) Control (P) 2	0~40	10		○		○	
✓10-21	P Gain of Zero Speed	0~40	10		○		○	
✓10-29	PG Mechanical Gear A2	1~5000	100		○		○	○
✓10-30	PG Mechanical Gear B2	1~5000	100		○		○	○

Group 11 Advanced Parameters

Updated parameters 11-00 and 11-09~11-10 and new parameters 11-18~11-40.

Pr.	Explanation	Settings	Factory Setting	VF	VFP	SVC	FOCP	TQCP
✓11-00	System Control	bit 0: ASR Auto tuning bit 1: Inertia estimate bit 2: Zero Servo bit 3: Reserved bit 4: Enable gain adjustment of position loop KP	0				○	
✓11-07	Detection Time for Phase-loss	0.01~600.00 sec	0.20	○	○	○	○	○
11-08	Reserved							
✓11-09	Level of Phase-loss	0.0~320.0	60.0	○	○	○	○	○
11-10	Speed Feed Forward Gain	0~100%	0				○	
✓11-11	Zero-speed Bandwidth	0~40Hz	10		○			○
✓11-12	Speed Response of Flux Weakening Area	0: Disable 0~150%	65					
✓11-13	Notch Filter Depth	0~20db	0					
✓11-14	Notch Filter Frequency	0.00~200.00	0.00				○	
✓11-15	Gain Value of Slip Compensation	0.00~1.00	1.00			○		
✓11-16	Low-pass Filter Time of Keypad Display	0.001~65.535sec	0.100	○	○	○	○	○
✓11-17	Low-pass Filter Time of PG2 Pulse Input	0.000~65.535sec	0.100	○	○	○	○	
✓11-18	APR Gain	0.00~40.00	10.00				○	
✓11-19	APR Curve Time	0.00~655.35 sec	3.00				○	
11-20 11-28	Reserved							
11-29	Accumulative Operation Time of Phase-loss	0~65535 (hour)	0	○	○	○	○	○
11-30 11-40	Reserved							

4.2.3 Version 2.05

New or update parameter groups are:

Group 0 System Parameters

Group 2: Digital Input/Output Parameters

Group 3: Analog Input/Output Parameters

Group 5: Motor Parameters

Group 6: Protection Parameters

Group 7: Special Parameters

Group 8: High-function PID Parameters

Group 9: Communication Parameters

Group 10: Speed Feedback Control Parameters

Version 2.05

Group 0 System Parameters

Pr.	Explanation	Settings	Factory Setting	VF	VFP	SVC	FOCPG	TOCPG
∞00-04	Content of Multi Function Display	0: Display output current (A) 1: Display counter value (C) 2: Display output frequency (H) 3: Display DC-BUS voltage (U) 4: Display output voltage (E) 5: Output power factor angle (n) 6: Display output power (kW) 7: Display actual motor speed (r) 8: Display estimate output torque in N-m (t) 9: Display PG position (G) 10: Display PID feedback in % (b) 11: Display AVI in % (1.) 12: Display ACI in % (2.) 13: Display AUI in % (3.) 14: Display the temperature of heat sink in °C (L) 15: Display the temperature of IGBT in °C (T) 16: The status of digital input (ON/OFF) (i) 17: The status of digital output (ON/OFF) (o) 18: Multi-step speed (S) 19: The corresponding CPU pin status of digital input (i.) 20: The corresponding CPU pin status of digital output (o.) 21: Number of actual motor revolution (PG1 of PG card) (Z) 22: Pulse input frequency (PG2 of PG card) (4) 23: Pulse input position (PG2 of PG card) (4.) 24: Pulse position control for whole operation (MI=37 and MI=ON) (P.) 25: Display the present reel diameter under the tension control in mm (d) 26: Display the present line speed under the tension control in m/min (L) 27: Display the present tension setting under the tension control in N (T.)	0	<input type="radio"/>	<input type="radio"/>	<input type="radio"/>	<input type="radio"/>	<input type="radio"/>
∞00-12	Constant/Variable Torque Selection	0: Constant Torque (150%) 1: Variable Torque (120%)	0	<input type="radio"/>	<input type="radio"/>	<input type="radio"/>	<input type="radio"/>	<input type="radio"/>
∞00-13	Optimal Acceleration/Deceleration Setting	0: Linear accel./decel. 1: Auto accel., linear decel. 2: Linear accel., auto decel. 3: Auto accel./decel. (auto calculate the accel./decel. time by actual load) 4: Stall prevention by auto accel./decel. (limited by 01-12 to 01-21)	0	<input type="radio"/>	<input type="radio"/>	<input type="radio"/>	<input type="radio"/>	<input type="radio"/>
∞00-23	Motor Direction Control	0: Enable forward/reverse 1: Disable reverse 2: Disable forward	0	<input type="radio"/>	<input type="radio"/>	<input type="radio"/>	<input type="radio"/>	<input type="radio"/>

Group 2 Digital Input/Output Parameters

Pr.	Explanation	Settings	Factory Setting	VF	VFP	SVC	FOCPG	TOCPG
02-01	Multi-Function Input Command 1 (MI1) (It is Stop terminal for 3-wire operation)	0: no function	1	<input type="checkbox"/>	<input type="checkbox"/>	<input type="checkbox"/>	<input type="checkbox"/>	<input type="checkbox"/>
		1: multi-step speed command 1/multi-step position command 1		<input type="checkbox"/>	<input type="checkbox"/>	<input type="checkbox"/>	<input type="checkbox"/>	<input type="checkbox"/>
		2: multi-step speed command 2/ multi-step position command 2		<input type="checkbox"/>	<input type="checkbox"/>	<input type="checkbox"/>	<input type="checkbox"/>	<input type="checkbox"/>
02-02	Multi-Function Input Command 2 (MI2)	3: multi-step speed command 3/ multi-step position command 3	2	<input type="checkbox"/>	<input type="checkbox"/>	<input type="checkbox"/>	<input type="checkbox"/>	<input type="checkbox"/>
		4: multi-step speed command 4/ multi-step position command 4		<input type="checkbox"/>	<input type="checkbox"/>	<input type="checkbox"/>	<input type="checkbox"/>	<input type="checkbox"/>
02-03	Multi-Function Input Command 3 (MI3)	5: Reset	3	<input type="checkbox"/>	<input type="checkbox"/>	<input type="checkbox"/>	<input type="checkbox"/>	<input type="checkbox"/>
		6: JOG command		<input type="checkbox"/>	<input type="checkbox"/>	<input type="checkbox"/>	<input type="checkbox"/>	<input type="checkbox"/>
02-04	Multi-Function Input Command 4 (MI4)	7: acceleration/deceleration speed inhibit	4	<input type="checkbox"/>	<input type="checkbox"/>	<input type="checkbox"/>	<input type="checkbox"/>	<input type="checkbox"/>
		8: the 1st, 2nd acceleration/deceleration time selection		<input type="checkbox"/>	<input type="checkbox"/>	<input type="checkbox"/>	<input type="checkbox"/>	<input type="checkbox"/>
02-05	Multi-Function Input Command 5 (MI5)	9: the 3rd, 4th acceleration/deceleration time selection	0	<input type="checkbox"/>	<input type="checkbox"/>	<input type="checkbox"/>	<input type="checkbox"/>	<input type="checkbox"/>
		10: EF input (Pr.07-36)		<input type="checkbox"/>	<input type="checkbox"/>	<input type="checkbox"/>	<input type="checkbox"/>	<input type="checkbox"/>
02-06	Multi-Function Input Command 6 (MI6) (specific terminal for TRG)	11: B.B. input	0	<input type="checkbox"/>	<input type="checkbox"/>	<input type="checkbox"/>	<input type="checkbox"/>	<input type="checkbox"/>
		12: Output stop		<input type="checkbox"/>	<input type="checkbox"/>	<input type="checkbox"/>	<input type="checkbox"/>	<input type="checkbox"/>
02-23	Multi-Function Input Command 7	13: cancel the setting of the optimal acceleration/deceleration time	0	<input type="checkbox"/>	<input type="checkbox"/>	<input type="checkbox"/>	<input type="checkbox"/>	<input type="checkbox"/>
02-24	Multi-Function Input Command 8	14: switch between drive settings 1 and 2	0	<input type="checkbox"/>	<input type="checkbox"/>	<input type="checkbox"/>	<input type="checkbox"/>	<input type="checkbox"/>
02-25	Multi-Function Input Command 9	15: operation speed command form AVI	0	<input type="checkbox"/>	<input type="checkbox"/>	<input type="checkbox"/>	<input type="checkbox"/>	<input type="checkbox"/>
02-26	Multi-Function Input Command 10	16: operation speed command form ACI	0	<input type="checkbox"/>	<input type="checkbox"/>	<input type="checkbox"/>	<input type="checkbox"/>	<input type="checkbox"/>
02-27	Multi-Function Input Command 11	17: operation speed command form AUI	0	<input type="checkbox"/>	<input type="checkbox"/>	<input type="checkbox"/>	<input type="checkbox"/>	<input type="checkbox"/>
02-28	Multi-Function Input Command 12	18: Emergency Stop (Pr.07-36)	0	<input type="checkbox"/>	<input type="checkbox"/>	<input type="checkbox"/>	<input type="checkbox"/>	<input type="checkbox"/>
02-29	Multi-Function Input Command 13	19: Digital Up command	0	<input type="checkbox"/>	<input type="checkbox"/>	<input type="checkbox"/>	<input type="checkbox"/>	<input type="checkbox"/>
02-30	Multi-Function Input Command 14	20: Digital Down command	0	<input type="checkbox"/>	<input type="checkbox"/>	<input type="checkbox"/>	<input type="checkbox"/>	<input type="checkbox"/>
		21: PID function disabled		<input type="checkbox"/>	<input type="checkbox"/>	<input type="checkbox"/>	<input type="checkbox"/>	<input type="checkbox"/>
		22: clear counter		<input type="checkbox"/>	<input type="checkbox"/>	<input type="checkbox"/>	<input type="checkbox"/>	<input type="checkbox"/>
		23: input the counter value (multi-function input command 6)		<input type="checkbox"/>	<input type="checkbox"/>	<input type="checkbox"/>	<input type="checkbox"/>	<input type="checkbox"/>
		24: FWD JOG command		<input type="checkbox"/>	<input type="checkbox"/>	<input type="checkbox"/>	<input type="checkbox"/>	<input type="checkbox"/>
		25: REV JOG command		<input type="checkbox"/>	<input type="checkbox"/>	<input type="checkbox"/>	<input type="checkbox"/>	<input type="checkbox"/>
		26: TQCPG/FOCPG mode selection		<input type="checkbox"/>	<input type="checkbox"/>	<input type="checkbox"/>	<input type="checkbox"/>	<input type="checkbox"/>
		27: ASR1/ASR2 selection		<input type="checkbox"/>	<input type="checkbox"/>	<input type="checkbox"/>	<input type="checkbox"/>	<input type="checkbox"/>
		28: Emergency stop (EF1)		<input type="checkbox"/>	<input type="checkbox"/>	<input type="checkbox"/>	<input type="checkbox"/>	<input type="checkbox"/>
		29: Signal confirmation for Y-connection		<input type="checkbox"/>	<input type="checkbox"/>	<input type="checkbox"/>	<input type="checkbox"/>	<input type="checkbox"/>
		30: Signal confirmation for Δ-connection		<input type="checkbox"/>	<input type="checkbox"/>	<input type="checkbox"/>	<input type="checkbox"/>	<input type="checkbox"/>
		31: High torque bias (by Pr.07-29)		<input type="checkbox"/>	<input type="checkbox"/>	<input type="checkbox"/>	<input type="checkbox"/>	<input type="checkbox"/>
		32: Middle torque bias (by Pr.07-30)		<input type="checkbox"/>	<input type="checkbox"/>	<input type="checkbox"/>	<input type="checkbox"/>	<input type="checkbox"/>
		33: Low torque bias (by Pr.07-31)		<input type="checkbox"/>	<input type="checkbox"/>	<input type="checkbox"/>	<input type="checkbox"/>	<input type="checkbox"/>
		34: Enable multi-step position control		<input type="checkbox"/>	<input type="checkbox"/>	<input type="checkbox"/>	<input type="checkbox"/>	<input type="checkbox"/>
		35: Enable position control		<input type="checkbox"/>	<input type="checkbox"/>	<input type="checkbox"/>	<input type="checkbox"/>	<input type="checkbox"/>
		36: Enable multi-step position learning function (valid at stop)		<input type="checkbox"/>	<input type="checkbox"/>	<input type="checkbox"/>	<input type="checkbox"/>	<input type="checkbox"/>
		37: Enable pulse position input command		<input type="checkbox"/>	<input type="checkbox"/>	<input type="checkbox"/>	<input type="checkbox"/>	<input type="checkbox"/>
		38: Disable write EEPROM function		<input type="checkbox"/>	<input type="checkbox"/>	<input type="checkbox"/>	<input type="checkbox"/>	<input type="checkbox"/>
		39: Torque command direction		<input type="checkbox"/>	<input type="checkbox"/>	<input type="checkbox"/>	<input type="checkbox"/>	<input type="checkbox"/>
		40: Force stop		<input type="checkbox"/>	<input type="checkbox"/>	<input type="checkbox"/>	<input type="checkbox"/>	<input type="checkbox"/>
		41: Serial position clock		<input type="checkbox"/>	<input type="checkbox"/>	<input type="checkbox"/>	<input type="checkbox"/>	<input type="checkbox"/>
		42: Serial position input		<input type="checkbox"/>	<input type="checkbox"/>	<input type="checkbox"/>	<input type="checkbox"/>	<input type="checkbox"/>
		43: Analog input resolution selection		<input type="checkbox"/>	<input type="checkbox"/>	<input type="checkbox"/>	<input type="checkbox"/>	<input type="checkbox"/>
		44: Enable initial reel diameter		<input type="checkbox"/>	<input type="checkbox"/>	<input type="checkbox"/>	<input type="checkbox"/>	<input type="checkbox"/>
		45: Reset initial reel diameter 1		<input type="checkbox"/>	<input type="checkbox"/>	<input type="checkbox"/>	<input type="checkbox"/>	<input type="checkbox"/>
		46: Reset initial reel diameter 2		<input type="checkbox"/>	<input type="checkbox"/>	<input type="checkbox"/>	<input type="checkbox"/>	<input type="checkbox"/>
47: Reset PID control integration of tension	<input type="checkbox"/>	<input type="checkbox"/>	<input type="checkbox"/>	<input type="checkbox"/>	<input type="checkbox"/>			

Pr.	Explanation	Settings	Factory Setting	VF	VFPG	SVC	FOCPG	TQCPG
		48: Mechanical gear ratio switch			<input type="checkbox"/>	<input type="checkbox"/>	<input type="checkbox"/>	<input type="checkbox"/>
		49: Enable Drive		<input type="checkbox"/>	<input type="checkbox"/>	<input type="checkbox"/>	<input type="checkbox"/>	<input type="checkbox"/>
		50: Reserved						
↗02-11	Multi-function Output 1 RA, RB, RC(Relay1)	0: No function 1: Operation indication	11	<input type="checkbox"/>	<input type="checkbox"/>	<input type="checkbox"/>	<input type="checkbox"/>	<input type="checkbox"/>
↗02-12	Multi-function Output 2 MRA, MRC (Relay2)	2: Operation speed attained 3: Desired frequency attained 1 (Pr.02-19)	1	<input type="checkbox"/>	<input type="checkbox"/>	<input type="checkbox"/>	<input type="checkbox"/>	<input type="checkbox"/>
↗02-13	Multi-function Output 3 (MO1)	4: Desired frequency attained 2 (Pr.02-21) 5: Zero speed (frequency command) 6: Zero speed with stop (frequency command) 7: Over torque (OT1) (Pr.06-06-06-08) 8: Over torque (OT2) (Pr.06-09-06-11)	0	<input type="checkbox"/>	<input type="checkbox"/>	<input type="checkbox"/>	<input type="checkbox"/>	<input type="checkbox"/>
↗02-14	Multi-function Output 4 (MO2)	9: Drive ready 10: User-defined Low-voltage Detection 11: Malfunction indication	0	<input type="checkbox"/>	<input type="checkbox"/>	<input type="checkbox"/>	<input type="checkbox"/>	<input type="checkbox"/>
↗02-35	Multi-function Output 5 (MO3)	12: Mechanical brake release (Pr.02-31) 13: Overheat 14: Software brake signal indication		<input type="checkbox"/>	<input type="checkbox"/>	<input type="checkbox"/>	<input type="checkbox"/>	<input type="checkbox"/>
↗02-36	Multi-function Output 6 (MO4)	15: PID feedback error 16: Slip error (σSL) 17: Terminal count value attained (Pr.02-16)		<input type="checkbox"/>	<input type="checkbox"/>	<input type="checkbox"/>	<input type="checkbox"/>	<input type="checkbox"/>
↗02-37	Multi-function Output 7 (MO5)	18: Preliminary count value attained (Pr.02-17) 19: Baseblock (B.B.) Indication 20: Warning output		<input type="checkbox"/>	<input type="checkbox"/>	<input type="checkbox"/>	<input type="checkbox"/>	<input type="checkbox"/>
↗02-38	Multi-function Output 8 (MO6)	21: Over voltage warning 22: Over-current stall prevention warning 23: Over-voltage stall prevention warning		<input type="checkbox"/>	<input type="checkbox"/>	<input type="checkbox"/>	<input type="checkbox"/>	<input type="checkbox"/>
↗02-39	Multi-function Output 9 (MO7)	24: Operation mode indication 25: Forward command 26: Reverse command		<input type="checkbox"/>	<input type="checkbox"/>	<input type="checkbox"/>	<input type="checkbox"/>	<input type="checkbox"/>
↗02-40	Multi-function Output 10 (MO8)	27: Output when current ≥ Pr.02-32 28: Output when current < Pr.02-32 29: Output when frequency ≥ Pr.02-33		<input type="checkbox"/>	<input type="checkbox"/>	<input type="checkbox"/>	<input type="checkbox"/>	<input type="checkbox"/>
↗02-41	Multi-function Output 11 (MO9)	30: Output when frequency < Pr.02-33 31: Y-connection for the motor coil 32: Δ connection for the motor coil		<input type="checkbox"/>	<input type="checkbox"/>	<input type="checkbox"/>	<input type="checkbox"/>	<input type="checkbox"/>
↗02-42	Multi-function Output 12 (MOA)	33: Zero speed (actual output frequency) 34: Zero speed with Stop (actual output frequency) 35: Error output selection 1 (Pr.06-23) 36: Error output selection 2 (Pr.06-24) 37: Error output selection 3 (Pr.06-25) 38: Error output selection 4 (Pr.06-26) 39: Position attained (Pr.10-19) 40: Speed attained (including zero speed) 41: Multi-position attained 42: Crane function 43: Motor zero-speed output (Pr.02-43) 44: Max. reel diameter attained 45: Empty reel diameter attained 46: Broken belt detection 47: Break release at stop 48: Error PID feedback of tension 49: Reserved 50: Reserved		<input type="checkbox"/>	<input type="checkbox"/>	<input type="checkbox"/>	<input type="checkbox"/>	<input type="checkbox"/>

Group 3 Analog Input/Output Parameters

Pr.	Explanation	Settings	Factory Setting	VF	VFPG	SVC	FOCPG	TQCPG	
↗03-18	Analog Output 1	0: Output frequency (Hz)	0	<input type="checkbox"/>	<input type="checkbox"/>	<input type="checkbox"/>	<input type="checkbox"/>	<input type="checkbox"/>	
		1: Frequency command (Hz)		<input type="checkbox"/>	<input type="checkbox"/>	<input type="checkbox"/>	<input type="checkbox"/>	<input type="checkbox"/>	
↗03-21	Analog Output 2	2: Motor speed (Hz)		<input type="checkbox"/>	<input type="checkbox"/>	<input type="checkbox"/>	<input type="checkbox"/>	<input type="checkbox"/>	
		3: Output current (rms)		<input type="checkbox"/>	<input type="checkbox"/>	<input type="checkbox"/>	<input type="checkbox"/>	<input type="checkbox"/>	
↗03-24	Analog Output 3	4: Output voltage		<input type="checkbox"/>	<input type="checkbox"/>	<input type="checkbox"/>	<input type="checkbox"/>	<input type="checkbox"/>	
		5: DC Bus Voltage		<input type="checkbox"/>	<input type="checkbox"/>	<input type="checkbox"/>	<input type="checkbox"/>	<input type="checkbox"/>	
		6: Power factor		<input type="checkbox"/>	<input type="checkbox"/>	<input type="checkbox"/>	<input type="checkbox"/>	<input type="checkbox"/>	
		7: Power		<input type="checkbox"/>	<input type="checkbox"/>	<input type="checkbox"/>	<input type="checkbox"/>	<input type="checkbox"/>	
		8: Output torque		<input type="checkbox"/>	<input type="checkbox"/>	<input type="checkbox"/>	<input type="checkbox"/>	<input type="checkbox"/>	
		9: AVI		<input type="checkbox"/>	<input type="checkbox"/>	<input type="checkbox"/>	<input type="checkbox"/>	<input type="checkbox"/>	
		10: ACI		<input type="checkbox"/>	<input type="checkbox"/>	<input type="checkbox"/>	<input type="checkbox"/>	<input type="checkbox"/>	
		11: AUI		<input type="checkbox"/>	<input type="checkbox"/>	<input type="checkbox"/>	<input type="checkbox"/>	<input type="checkbox"/>	
		12: q-axis current		<input type="checkbox"/>	<input type="checkbox"/>	<input type="checkbox"/>	<input type="checkbox"/>	<input type="checkbox"/>	
		13: q-axis feedback value		<input type="checkbox"/>	<input type="checkbox"/>	<input type="checkbox"/>	<input type="checkbox"/>	<input type="checkbox"/>	
		14: d-axis current		<input type="checkbox"/>	<input type="checkbox"/>	<input type="checkbox"/>	<input type="checkbox"/>	<input type="checkbox"/>	
		15: d-axis feedback value		<input type="checkbox"/>	<input type="checkbox"/>	<input type="checkbox"/>	<input type="checkbox"/>	<input type="checkbox"/>	
		16: q-axis voltage		<input type="checkbox"/>	<input type="checkbox"/>	<input type="checkbox"/>	<input type="checkbox"/>	<input type="checkbox"/>	
		17: d-axis voltage		<input type="checkbox"/>	<input type="checkbox"/>	<input type="checkbox"/>	<input type="checkbox"/>	<input type="checkbox"/>	
		18: Torque command		<input type="checkbox"/>	<input type="checkbox"/>	<input type="checkbox"/>	<input type="checkbox"/>	<input type="checkbox"/>	
		19: Pulse frequency command		<input type="checkbox"/>	<input type="checkbox"/>	<input type="checkbox"/>	<input type="checkbox"/>	<input type="checkbox"/>	<input type="checkbox"/>
		↗03-19		Gain for Analog Output 1	0~200.0%	100.0	<input type="checkbox"/>	<input type="checkbox"/>	<input type="checkbox"/>
↗03-20	Analog Output 1 Value in REV Direction	0: Absolute value in REV direction 1: Output 0V in REV direction 2: Enable output voltage in REV direction	0	<input type="checkbox"/>	<input type="checkbox"/>	<input type="checkbox"/>	<input type="checkbox"/>	<input type="checkbox"/>	
↗03-22	Gain for Analog Output 2	0~200.0%	100.0	<input type="checkbox"/>	<input type="checkbox"/>	<input type="checkbox"/>	<input type="checkbox"/>	<input type="checkbox"/>	
↗03-23	Analog Output 2 Value in REV Direction	0: Absolute value in REV direction 1: Output 0V in REV direction 2: Enable output voltage in REV direction	0	<input type="checkbox"/>	<input type="checkbox"/>	<input type="checkbox"/>	<input type="checkbox"/>	<input type="checkbox"/>	
↗03-25	Gain for Analog Output 3	0~200.0%	100.0	<input type="checkbox"/>	<input type="checkbox"/>	<input type="checkbox"/>	<input type="checkbox"/>	<input type="checkbox"/>	
↗03-26	Analog Output 3 Value in REV Direction	0: Absolute value in REV direction 1: Output 0V in REV direction 2: Enable output voltage in REV direction	0	<input type="checkbox"/>	<input type="checkbox"/>	<input type="checkbox"/>	<input type="checkbox"/>	<input type="checkbox"/>	

Group 5 Motor Parameters

Pr.	Explanation	Settings	Factory Setting	VF	VFPG	SVC	FOCPG	TQCPG
05-01	Full-load Current of Motor 1 (A)	40~120% of drive's rated current	###	<input type="checkbox"/>	<input type="checkbox"/>	<input type="checkbox"/>	<input type="checkbox"/>	<input type="checkbox"/>
↗05-02	Rated power of Motor 1 (kW)	0~655.35	###			<input type="checkbox"/>	<input type="checkbox"/>	<input type="checkbox"/>
05-06	Stator Resistance (Rs) of Motor 1	0~65.535 Ω	####			<input type="checkbox"/>	<input type="checkbox"/>	<input type="checkbox"/>
05-07	Rotor Resistance (Rr) of Motor 1	0~65.535 Ω	####			<input type="checkbox"/>	<input type="checkbox"/>	<input type="checkbox"/>
05-08	Magnetizing Inductance (Lm) of Motor 1	0~6553.5mH	##			<input type="checkbox"/>	<input type="checkbox"/>	<input type="checkbox"/>
05-09	Stator inductance (Lx) of Motor 1	0~6553.5mH	##			<input type="checkbox"/>	<input type="checkbox"/>	<input type="checkbox"/>
05-13	Full-load Current of Motor 2 (A)	40~120%	###	<input type="checkbox"/>	<input type="checkbox"/>	<input type="checkbox"/>	<input type="checkbox"/>	<input type="checkbox"/>
↗05-14	Rated Power of Motor 2 (kW)	0~655.35	###			<input type="checkbox"/>	<input type="checkbox"/>	<input type="checkbox"/>
05-17	No-load Current of Motor 2 (A)	0: factory setting of Pr.05-01	###		<input type="checkbox"/>	<input type="checkbox"/>	<input type="checkbox"/>	<input type="checkbox"/>
05-18	Stator Resistance(Rs) of Motor 2	0~65.535 Ω	####			<input type="checkbox"/>	<input type="checkbox"/>	<input type="checkbox"/>
05-19	Rotor Resistance(Rr) of Motor 2	0~65.535 Ω	####			<input type="checkbox"/>	<input type="checkbox"/>	<input type="checkbox"/>
05-20	Magnetizing Inductance (Lm) of Motor 2	0~6553.5mH	##			<input type="checkbox"/>	<input type="checkbox"/>	<input type="checkbox"/>

Pr.	Explanation	Settings	Factory Setting	VF	VFPG	SVC	FOCPG	TOCPG
05-21	Stator Inductance(Lx) of Motor 2	0-6553.5mH	##			○	○	○

Group 6 Protection Parameters

Pr.	Explanation	Settings	Factory Setting	VF	VFPG	SVC	FOCPG	TOCPG
↗06-03	Over-current Stall Prevention during Acceleration	00-250%(100%: drive's rated current)	170	○	○	○		
↗06-04	Over-current Stall Prevention during Operation	00-250%(100%: drive's rated current)	170	○	○	○		
↗06-07	Over-torque Detection Level (OT1)	10-250%(100%: drive's rated current)	150	○	○	○	○	○
↗06-10	Over-torque Detection Level (OT2)	10-250%(100%: drive's rated current)	150	○	○	○	○	○
↗06-12	Current Limit	0-250%(100%: drive's rated current)	150				○	○
06-17	Present Fault Record	0: No fault	0	○	○	○	○	○
06-18	Second Most Recent Fault Record	1: Over-current during acceleration (ocA)	0	○	○	○	○	○
		2: Over-current during deceleration (ocd)		○	○	○	○	○
		3: Over-current during constant speed (ocn)		○	○	○	○	○
		4: Ground fault (GFF)		○	○	○	○	○
06-19	Third Most Recent Fault Record	5: IGBT short-circuit (occ)	0	○	○	○	○	○
		6: Over-current at stop (ocS)		○	○	○	○	○
		7: Over-voltage during acceleration (ovA)		○	○	○	○	○
06-20	Fourth Most Recent Fault Record	8: Over-voltage during deceleration (ovd)	0	○	○	○	○	○
		9: Over-voltage during constant speed (ovn)		○	○	○	○	○
		10: Over-voltage at stop (ovS)		○	○	○	○	○
06-21	Fifth Most Recent Fault Record	11: Low-voltage during acceleration (LvA)	0	○	○	○	○	○
		12: Low-voltage during deceleration (Lvd)		○	○	○	○	○
		13: Low-voltage during constant speed (Lvn)		○	○	○	○	○
		14: Low-voltage at stop (LvS)		○	○	○	○	○
		15: Phase loss (PHL)		○	○	○	○	○
06-22	Sixth Most Recent Fault Record	16: IGBT over-heat (oH1)	0	○	○	○	○	○
		17: Heat sink over-heat (oH2)(for 40HP above)		○	○	○	○	○
		18: TH1: IGBT hardware failure (tH1o)		○	○	○	○	○
		19: TH2: Heat sink hardware failure(tH2o)		○	○	○	○	○
		20: Fan error signal output		○	○	○	○	○
		21: over-load (oL) (when it exceeds 150% rated current, 1 min later it will be overload)		○	○	○	○	○
		22: Electronics thermal relay 1 (EoL1)		○	○	○	○	○
		23: Electronics thermal relay 2 (EoL2)		○	○	○	○	○
		24: Motor PTC overheat (oH3)		○	○	○	○	○
		25: Fuse error (FuSE)		○	○	○	○	○
		26: over-torque 1 (ot1)		○	○	○	○	○
		27: over-torque 1 (ot2)		○	○	○	○	○
		28: Reserved						
		29: Reserved						
		30: Memory write-in error (cF1)		○	○	○	○	○
		31: Memory read-out error (cF2)		○	○	○	○	○
		32: Isum current detection error (cd0)		○	○	○	○	○
		33: U-phase current detection error (cd1)		○	○	○	○	○
		34: V-phase current detection error (cd2)		○	○	○	○	○
		35: W-phase current detection error (cd3)		○	○	○	○	○
36: Clamp current detection error (Hd0)	○	○	○	○	○			
37: Over-current detection error (Hd1)	○	○	○	○	○			
38: Over-voltage detection error (Hd2)	○	○	○	○	○			
39: Ground current detection error (Hd3)	○	○	○	○	○			
40: Auto tuning error (AuE)								
41: PID feedback loss (AFE)	○	○	○	○	○			
42: PG feedback error (PGF1)								
43: PG feedback loss (PGF2)								
44: PG feedback stall (PGF3)								

Pr.	Explanation	Settings	Factory Setting	VF	VFP	SVC	FOCPG	TQCPG
		45: PG slip error (PGF4)		<input type="radio"/>	<input type="radio"/>	<input type="radio"/>	<input type="radio"/>	<input type="radio"/>
		46: PG ref input error (PGr1)		<input type="radio"/>	<input type="radio"/>	<input type="radio"/>	<input type="radio"/>	<input type="radio"/>
		47: PG ref loss (PGr2)		<input type="radio"/>	<input type="radio"/>	<input type="radio"/>	<input type="radio"/>	<input type="radio"/>
		48: Analog current input loss (ACE)		<input type="radio"/>	<input type="radio"/>	<input type="radio"/>	<input type="radio"/>	<input type="radio"/>
		49: External fault input (EF)		<input type="radio"/>	<input type="radio"/>	<input type="radio"/>	<input type="radio"/>	<input type="radio"/>
		50: Emergency stop (EF1)		<input type="radio"/>	<input type="radio"/>	<input type="radio"/>	<input type="radio"/>	<input type="radio"/>
		51: External Base Block (B.B.)		<input type="radio"/>	<input type="radio"/>	<input type="radio"/>	<input type="radio"/>	<input type="radio"/>
		52: Password error (PcodE)		<input type="radio"/>	<input type="radio"/>	<input type="radio"/>	<input type="radio"/>	<input type="radio"/>
		53: Reserved						
		54: Communication error (cE1)		<input type="radio"/>	<input type="radio"/>	<input type="radio"/>	<input type="radio"/>	<input type="radio"/>
		55: Communication error (cE2)		<input type="radio"/>	<input type="radio"/>	<input type="radio"/>	<input type="radio"/>	<input type="radio"/>
		56: Communication error (cE3)		<input type="radio"/>	<input type="radio"/>	<input type="radio"/>	<input type="radio"/>	<input type="radio"/>
		57: Communication error (cE4)		<input type="radio"/>	<input type="radio"/>	<input type="radio"/>	<input type="radio"/>	<input type="radio"/>
		58: Communication Time-out (cE10)		<input type="radio"/>	<input type="radio"/>	<input type="radio"/>	<input type="radio"/>	<input type="radio"/>
		59: PU time-out (cP10)		<input type="radio"/>	<input type="radio"/>	<input type="radio"/>	<input type="radio"/>	<input type="radio"/>
		60: Brake transistor error (bF)		<input type="radio"/>	<input type="radio"/>	<input type="radio"/>	<input type="radio"/>	<input type="radio"/>
		61: Y-connection/Δ-connection switch error (ydc)		<input type="radio"/>	<input type="radio"/>	<input type="radio"/>	<input type="radio"/>	<input type="radio"/>
		62: Decel. Energy Backup Error (dEb)		<input type="radio"/>	<input type="radio"/>	<input type="radio"/>	<input type="radio"/>	<input type="radio"/>
		63: Slip error (oSL)		<input type="radio"/>	<input type="radio"/>	<input type="radio"/>	<input type="radio"/>	<input type="radio"/>
		64: Broken belt error (bEb)		<input type="radio"/>	<input type="radio"/>	<input type="radio"/>	<input type="radio"/>	<input type="radio"/>
		65: Error PID feedback signal of tension (tdEv)		<input type="radio"/>	<input type="radio"/>	<input type="radio"/>	<input type="radio"/>	<input type="radio"/>
06-32	Output Frequency for Malfunction	0.00~655.35 Hz	Read-only	<input type="radio"/>	<input type="radio"/>	<input type="radio"/>	<input type="radio"/>	<input type="radio"/>
06-33	Output Voltage for Malfunction	0.0~6553.5 V	Read-only	<input type="radio"/>	<input type="radio"/>	<input type="radio"/>	<input type="radio"/>	<input type="radio"/>
06-34	DC Voltage for Malfunction	0.0~6553.5 V	Read-only	<input type="radio"/>	<input type="radio"/>	<input type="radio"/>	<input type="radio"/>	<input type="radio"/>
06-35	Output Current for Malfunction	0.00~655.35 Amp	Read-only	<input type="radio"/>	<input type="radio"/>	<input type="radio"/>	<input type="radio"/>	<input type="radio"/>
06-36	IGBT Temperature for Malfunction	0.0~6553.5 °C	Read-only	<input type="radio"/>	<input type="radio"/>	<input type="radio"/>	<input type="radio"/>	<input type="radio"/>

Group 7 Special Parameters

Pr.	Explanation	Settings	Factory Setting	VF	VFP	SVC	FOCPG	TQCPG
↗07-05	Proportional Gain for DC Brake	1~500	50	<input type="radio"/>	<input type="radio"/>	<input type="radio"/>		
↗07-19	Fan Control	0: Fan always ON 1: 1 minute after AC motor drive stops, fan will be OFF 2: AC motor drive runs and fan ON, AC motor drive stops and fan OFF 3: Fan ON to run when preliminary heat sink temperature(around 60°C) attained 4: Fan always OFF	0	<input type="radio"/>	<input type="radio"/>	<input type="radio"/>	<input type="radio"/>	<input type="radio"/>
07-27	Source of Torque Offset	0: Disable 1: Analog input (Pr.03-00) 2: Torque offset setting 3: Control by external terminal (by Pr.07-29 to Pr.07-31)	0			<input type="radio"/>	<input type="radio"/>	<input type="radio"/>
07-36	Emergency Stop (EF) & Forced Stop Selection	0: Coast stop 1: By deceleration Time 1 2: By deceleration Time 2 3: By deceleration Time 3 4: By deceleration Time 4 5: System Deceleration 6: Automatic Deceleration	0	<input type="radio"/>	<input type="radio"/>	<input type="radio"/>	<input type="radio"/>	<input type="radio"/>

Group 8 High-function PID Parameters

Pr.	Explanation	Settings	Factory Setting	VF	VFPG	SVC	FOCPG	TOCPG
08-00	Input Terminal for PID Feedback	0: No function 1: Negative PID feedback from external terminal AVI (Pr.03-00) 2: Negative PID feedback from PG card (Pr.10-15, skip direction) 3: Negative PID feedback from PG card (Pr.10-15) 4: Positive PID feedback from external terminal AVI (Pr.03-00) 5: Positive PID feedback from PG card (Pr.10-15, skip direction) 6: Positive PID feedback from PG card (Pr.10-15)	0	<input type="radio"/>	<input type="radio"/>	<input type="radio"/>	<input type="radio"/>	<input type="radio"/>
08-21	Tension Control Selection	0: Disable 1: Tension closed-loop, speed mode 2: Line speed closed-loop, speed mode 3: Reserved 4: Tension open-loop, torque mode	0	<input type="radio"/>	<input type="radio"/>	<input type="radio"/>	<input type="radio"/>	<input type="radio"/>
08-22	Wind Mode	0: Rewind 1: Unwind	0	<input type="radio"/>	<input type="radio"/>	<input type="radio"/>	<input type="radio"/>	<input type="radio"/>
08-23	Mechanical Gear A at Reel	1-65535	100	<input type="radio"/>	<input type="radio"/>	<input type="radio"/>	<input type="radio"/>	<input type="radio"/>
08-24	Mechanical Gear B at Motor	1-65535	100	<input type="radio"/>	<input type="radio"/>	<input type="radio"/>	<input type="radio"/>	<input type="radio"/>
∕08-29	Proportional Gain 1 of Tension PID P	0.0~1000.0	50.0	<input type="radio"/>	<input type="radio"/>	<input type="radio"/>	<input type="radio"/>	<input type="radio"/>
∕08-30	Integral Time of Tension PID I	0.00~500.00 sec	1.00	<input type="radio"/>	<input type="radio"/>	<input type="radio"/>	<input type="radio"/>	<input type="radio"/>
∕08-32	Proportional Gain 2 of Tension PID P	0.0~1000.0	50.0	<input type="radio"/>	<input type="radio"/>	<input type="radio"/>	<input type="radio"/>	<input type="radio"/>
∕08-33	Integral Time 2 of Tension PID I	0.00~500.00 sec	1.00	<input type="radio"/>	<input type="radio"/>	<input type="radio"/>	<input type="radio"/>	<input type="radio"/>
08-36	Tension/Line Speed PID Output Limit	0~100.00%	20.00	<input type="radio"/>	<input type="radio"/>	<input type="radio"/>	<input type="radio"/>	<input type="radio"/>
08-40	Pulse Number for Each Meter	0.0~6000.0 pulse/m	0.0	<input type="radio"/>	<input type="radio"/>	<input type="radio"/>	<input type="radio"/>	<input type="radio"/>
08-41	Current Line Speed	0.0~3000.0m/min	0.0	<input type="radio"/>	<input type="radio"/>	<input type="radio"/>	<input type="radio"/>	<input type="radio"/>
08-46	Initial Reel Diameter	0.0~6000.0mm	1.0	<input type="radio"/>	<input type="radio"/>	<input type="radio"/>	<input type="radio"/>	<input type="radio"/>
08-47	Initial Reel Diameter 1	0.0~6000.0mm	1.0	<input type="radio"/>	<input type="radio"/>	<input type="radio"/>	<input type="radio"/>	<input type="radio"/>
08-48	Initial Reel Diameter 2	0.0~6000.0mm	1.0	<input type="radio"/>	<input type="radio"/>	<input type="radio"/>	<input type="radio"/>	<input type="radio"/>
08-55	Smart Start Function	0: Disable 1: Enable 2: In unwind mode, rewind in reverse direction	1	<input type="radio"/>	<input type="radio"/>	<input type="radio"/>	<input type="radio"/>	<input type="radio"/>
08-61	Allowance Difference of Reel Diameter of Broken Belt Detection	1.0~6000.0mm	100.0	<input type="radio"/>	<input type="radio"/>	<input type="radio"/>	<input type="radio"/>	<input type="radio"/>
08-64	Allowance Error Detection Time of Tension/Line Speed PID Feedback	0.0~10.0 sec	0.5	<input type="radio"/>	<input type="radio"/>	<input type="radio"/>	<input type="radio"/>	<input type="radio"/>
08-65	Error Treatment of Tension/Line Speed PID Feedback	0: Warn and keep operation 1: Warn and coast to stop 2: Warn and ramp to stop	0	<input type="radio"/>	<input type="radio"/>	<input type="radio"/>	<input type="radio"/>	<input type="radio"/>

Group 9 Communication Parameters

Pr.	Explanation	Settings	Factory Setting	VF	VFPG	SVC	FOCPG	TOCPG
09-22	Display Digital Value of Analog Output 2	0~4095	Read-only	<input type="radio"/>	<input type="radio"/>	<input type="radio"/>	<input type="radio"/>	<input type="radio"/>
09-23	Display Digital Value of Analog Output 3	0~4095	Read-only	<input type="radio"/>	<input type="radio"/>	<input type="radio"/>	<input type="radio"/>	<input type="radio"/>

Group 10 Speed Feedback Control Parameters

Pr.	Explanation	Settings	Factory Setting	VF	VFPG	SVC	FOCPG	TQCPG
↗10-02	Encoder Feedback Fault Treatment	0: Warn and keep operation 1: Warn and ramp to stop 2: Warn and coast to stop	2		○		○	○
↗10-03	Detection Time for Encoder Feedback Fault	0.00~10.0 sec	1.0		○		○	○
↗10-04	ASR (Auto Speed Regulation) Control (P) 1	0~40	10		○		○	○
↗10-05	ASR (Auto Speed Regulation) Control (I) 1	0.000~10.000 sec	0.100		○		○	○
↗10-06	ASR (Auto Speed Regulation) Control (P) 2	0~40	10		○		○	○
↗10-07	ASR (Auto Speed Regulation) Control (I) 2	0.000~10.000 sec	0.100		○		○	○
↗10-08	ASR 1/ASR2 Switch Frequency	5.00~600.00Hz	7.00		○		○	○
↗10-09	Low Pass Filter Time of ASR Output	0.000~0.350 sec	0.008				○	○
↗10-10	Encoder Stall Level	0~120% (0: disable)	115		○		○	
↗10-11	Encoder Stall Detection Time	0.0~2.0 sec	0.1		○		○	
↗10-12	Encoder Slip Range	0~50% (0: disable)	50		○		○	
↗10-13	Encoder Slip Detection Time	0.0~10.0 sec	0.5		○		○	
↗10-14	Encoder Stall and Slip Error Treatment	0: Warn and keep operation 1: Warn and ramp to stop 2: Warn and coast to stop	2		○		○	
↗10-17	Electrical Gear A (PG1 of PG card)	1~5000	100		○		○	
↗10-18	Electrical Gear B (PG2 of PG card)	1~5000	100		○		○	
↗10-19	Positioning for Encoder Position	0~65535 pulses	0		○		○	
↗10-20	Range for Encoder Position Attained	0~20000 pulses	10		○		○	
↗10-21	P Gain of Zero Speed	0~40	10		○		○	○
↗10-22	I Gain of Zero Speed	0.000~10.000 sec	0.100		○		○	○
↗10-23	Feed Forward Gain of APR	0~100	30		○		○	
↗10-24	Deceleration Time for Internal Position/Waiting Time for Switching Max. Frequency	0.00~600.00 sec/00~6000.0 sec	3.00 3.0		○		○	
↗10-27	Mechanical Gear at Load A1	1~65535	100		○		○	○
↗10-28	Mechanical Gear at Motor B1	1~65535	100		○		○	○
↗10-29	Mechanical Gear at Load A2	1~65535	100		○		○	○
↗10-30	Mechanical Gear at Motor B2	1~65535	100		○		○	○

Group 11 Advanced Parameters

Pr.	Explanation	Settings	Factory Setting	VF	VFPG	SVC	FOCPG	TQCPG
11-00	System Control	bit 0: Auto tuning for ASR and APR bit 1: Inertia estimate (only for FOCPG mode) bit 2: Zero Servo bit 3: Reserved	0				<input type="radio"/>	<input type="radio"/>
11-10	Speed Feed Forward Gain	0~100%	0				<input type="radio"/>	

Version 2.07

Pr.	Explanation	Settings	Factory Setting	VF	VFPG	SVC	FOCPG	TQCPG
08-21	Tension Control Selection	0: Disable	0	<input type="radio"/>	<input type="radio"/>	<input type="radio"/>	<input type="radio"/>	
		1: Tension closed-loop, speed mode		<input type="radio"/>	<input type="radio"/>	<input type="radio"/>	<input type="radio"/>	
		2: Line speed closed-loop, speed mode		<input type="radio"/>	<input type="radio"/>	<input type="radio"/>	<input type="radio"/>	
		3: Tension close-loop, torque mode						<input type="radio"/>
		4: Tension open-loop, torque mode						<input type="radio"/>

4.3 Description of Parameter Settings

Group 0 User Parameters **↗**: This parameter can be set during operation.

00-00	Identity Code of the AC Motor Drive											
Control mode	VF	VFPG	SVC	FOCPG	TQCPG							Factory setting: ##
	Settings		Read Only									

00-01	Rated Current Display of the AC Motor Drive											
Control mode	VF	VFPG	SVC	FOCPG	TQCPG							Factory setting: ##
	Settings		Read Only									

 **Pr. 00-00 displays the identity code of the AC motor drive. The capacity, rated current, rated voltage and the max. carrier frequency relate to the identity code. Users can use the following table to check how the rated current, rated voltage and max. carrier frequency of the AC motor drive correspond to the identity code.**

 **Pr.00-01 displays the rated current of the AC motor drive. By reading this parameter the user can check if the AC motor drive is correct.**

 **The factory setting is rated current for the constant torque and can be set in Pr.00-12.**

230V Series												
kW	0.75	1.5	2.2	3.7	5.5	7.5	11	15	18.5	22	30	37
HP	1.0	2.0	3.0	5.0	7.5	10	15	20	25	30	40	50
Pr.00-00	4	6	8	10	12	14	16	18	20	22	24	26
Rated Current for Constant Torque (A)	5	7.5	11	17	25	33	49	65	75	90	120	146
Rated Current for Variable Torque (A)	6.3	9.4	13.8	21.3	31.3	41.3	61.3	81.3	93.8	113	150	183
Max. Carrier Frequency	15kHz								9kHz			

460V Series															
kW	0.75	1.5	2.2	3.7	5.5	7.5	11	15	18.5	22	30	37	45	55	75
HP	1.0	2.0	3.0	5.0	7.5	10	15	20	25	30	40	50	60	75	100
Pr.00-00	5	7	9	11	13	15	17	19	21	23	25	27	29	31	33
Rated Current for Constant Torque (A)	3	4.2	6	8.5	13	18	24	32	38	45	60	73	91	110	150
Rated Current for Variable Torque (A)	3.8	5.3	7.5	10.6	16.3	22.5	30	40	47.5	56.3	75	91.3	113.8	138	188
Max. Carrier Frequency	15kHz						9kHz				6kHz				

00-02 Parameter Reset

Control mode	VF	VFPG	SVC	FOCPG	TQCPG	Factory setting: 0
Settings	0	No Function				
	1	Read Only				
	2	Enable Group 11 Parameters Setting				
	8	Keypad Lock				
	9	All parameters are reset to factory settings (50Hz, 220V/380V)				
	10	All parameters are reset to factory settings (60Hz, 220V/440V)				

 **When it is set to 1, all parameters are read only except Pr.00-00~00-07 and it can be used with password setting for password protection.**

 **This parameter allows the user to reset all parameters to the factory settings except the fault records (Pr.06-17 ~ Pr.06-22).**

50Hz: Pr.01-01 is set to 50Hz and Pr.01-02 is set to 230V or 400V.

60Hz: Pr.01-01 is set to 60Hz and Pr.01-02 is set to 230V or 460V.

 **When Pr.00-02=08, the KPV-CE01 keypad is locked and only Pr.00-02 can be set. To unlock the keypad, set Pr.00-02=00.**

 **When Pr.00-02 is set to 1 or 8, Pr.00-02 setting should be set to 0 before setting to other setting.**



















 **After setting Pr.00-02 to 2, it can display group 11 to re-connect the keypad after disconnection or re-power on after the power off.**

00-03  Start-up Display Selection

Control mode	VF	VFPG	SVC	FOCPG	TQCPG	Factory setting: 0
Settings	0	Display the frequency command value. (LED F)				
	1	Display the actual output frequency (LED H)				
	2	Multifunction display, see Pr.00-04 (LED U)				
	3	Display the output current (A)				

 **This parameter determines the start-up display page after power is applied to the drive.**

00-04 Content of Multi-Function function Display

Control mode	VF	VFPG	SVC	FOCPG	TQCPG	Factory setting: 0
Settings	0					Display the output current in A supplied to the motor 
	1					Display the counter value which counts the number of pulses on TRG terminal (c) 
	2					Display actual output frequency (H) with PG feedback/ Display actual electric output frequency without PG feedback. 
	3					Display the actual DC BUS voltage in VDC of the AC motor drive (U) 
	4					Display the output voltage in VAC of terminals U, V, W to the motor (E) 
	5					Display the power factor angle in ° of terminals U, V, W to the motor (n) 
	6					Display the output power in kW of terminals U, V and W to the motor (P) 
	7					Display the actual motor speed in rpm (enabled when using with PG card) (r00: positive speed; -00: negative speed)  
	8					Display the estimated value of torque in Nm as it relates to current (t0.0: positive torque; -0.0: negative torque)  
	9					Display PG position (refer to NOTE1) 
	10					Display analog feedback signal value in % (b) 
	11					Display the signal of AVI analog input terminal in %. Range 0~10V corresponds to 0~100%. (1.) (refer to NOTE 2) 
	12					Display the signal of ACI analog input terminal in %. Range 4~20mA/0~10V corresponds to 0~100%. (2.) (refer to NOTE 2) 
	13					Display the signal of AUI analog input terminal in %. Range -10V~10V corresponds to -100~100%. (3.) (refer to NOTE 2) 
	14					Display the temperature of heat sink in °C. (t) 
	15					Display the temperature of IGBT in °C (T) 
	16					Display digital input status ON/OFF (Pr.02-10) (i) (refer to NOTE 3) 

00-04 Content of Multi-Function function Display

17	Display digital output status ON/OFF (Pr.02-15) (o) (refer to NOTE 4)	
18	Display multi-step speed (S)	
19	The corresponding CPU pin status of digital input (i.) (refer to NOTE 3)	
20	The corresponding CPU pin status of digital output (o.) (refer to NOTE 4)	
21	Number of actual motor revolution (PG1 of PG card). When the motor direction is changed or drive is stop, the counter will start from 0 (display will be changed to 0) (Max. 65535) (Z)	
22	Pulse input frequency (PG2 of PG card) (4)	
23	Pulse input position (PG2 of PG card) (max. 65535) (4.)	
24	Pulse position control for whole operation (MI=37 and MI=ON) (P.) (refer to NOTE5)	
25	Display the present reel diameter under the tension control in mm (d)	
26	Display the present line speed under the tension control in m/min (L)	
27	Display the present tension setting under the tension control in N (T.)	

NOTE

- When Pr.10-00 is set to 1000 and Pr.10-01 is set to 1/2, the display range for PG feedback will be from 0 to 4000.
When Pr.10-00 is set to 1000 and Pr.10-01 is set to 3/4/5, the display range for PG feedback will be from 0 to 1000.
Home position: If it has Z phase, Z phase will be regarded as home position. Otherwise, home position will be the encoder start up position.
- It can display negative values when setting analog input bias (Pr.03-03~03-08).
Example 1: assume that AVI input voltage is 0V, Pr.03-03 is 10.0% and Pr.03-06 is 4 (Serve bias as the center), the display will be .
Example 2: when AUI input voltage is -10V, it will display .
- Example: If REV, MI1 and MI6 are ON, the following table shows the status of the terminals.
0: OFF, 1: ON

Terminal	MI14	MI13	MI12	MI11	MI10	MI9	MI8	MI7	MI6	MI5	MI4	MI3	MI2	MI1	REV	FWD
Status	0	0	0	0	0	0	0	0	1	0	0	0	0	1	1	0

If REV, MI1 and MI6 are ON, the value is 0000 0000 1000 0110 in binary and 0086H in HEX.

When Pr.00-04 is set to "16" or "19", it will display "0086" with LED U is ON on the keypad KPV-CE01. The setting 16 is the status of digital input by Pr.02-10 setting and the setting 19 is the corresponding CPU pin status of digital input. User can set to 16 to monitor digital input status and then set to 19 to check if the wire is normal.

4. Assume that MRA: Pr.02-11 is set to 9 (Drive ready). After applying the power to the AC motor drive, if there is no other abnormal status, the contact will be ON. The display status will be shown as follows.

Terminal	Reserved				Reserved				Reserved				MO2	MO1	RA	MRA
Status	0	0	0	0	0	0	0	0	0	0	0	0	0	0	0	1

At the meanwhile, if Pr.00-04 is set to 17 or 20, it will display 0001 with LED U is ON on the keypad. The setting 17 is the status of digital output by Pr.02-15 setting and the setting 20 is the corresponding CPU pin status of digital output. User can set 17 to monitor the digital output status and then set to 20 to check if the wire is normal.

5. When Pr.00-04 is set to 24, user can get the difference between the pulse command and actual motor position to adjust Pr.11-18 by this display.

00-05 User Defined Coefficient K

Control mode	VF	VFP	SVC	FOCPG	TQCPG	Factory setting: 0
--------------	----	-----	-----	-------	-------	--------------------

Settings Digit 4: decimal point number (0 to 3)

Digit 0-3: 40 to 9999



It is used digital setting method

Digit 4: decimal point number (0: no decimal point, 1: 1 decimal point and so on.)

Digit 0-3: 40 to 9999 (the corresponding value for the max. frequency).

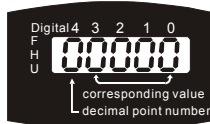





For example, if use uses rpm to display the motor speed and the corresponding value to the 4-pole motor 60Hz is 1800. This parameter can be set to 01800 to indicate that the corresponding value for 60Hz is 1800rpm. If the unit is rps, it can be set 10300 to indicate the corresponding value for 60Hz is

30.0 (a decimal point).

00-06 Software Version						
Control mode	VF	VFPG	SVC	FOCPG	TQCPG	Factory setting: Read Only
	Settings	Read Only				
	Display	#.##				

00-07  Password Input						Unit: 1
Control mode	VF	VFPG	SVC	FOCPG	TQCPG	Factory setting: 00
	Settings	1 to 9998 and 10000 to 65535				
	Display	00~02 (times of wrong password)				

 The function of this parameter is to input the password that is set in Pr.00-08. Input the correct password here to enable changing parameters. You are limited to a maximum of 3 attempts. After 3 consecutive failed attempts, a blinking “PcodE” will show up to force the user to restart the AC motor drive in order to try again to input the correct password.

 When forgetting password, you can decode by setting 9999 and press button  and repeat it again (setting 9999 and press button  again). Please note that all the settings will be set to factory setting.

00-08  Password Set						Unit: 1
Control mode	VF	VFPG	SVC	FOCPG	TQCPG	Factory setting: 00
	Settings	1 to 9998 and 10000 to 65535				
	Display	00	No password set or successful input in Pr. 00-07			
		01	Password has been set			

 To set a password to protect your parameter settings.

If the display shows 00, no password is set or password has been correctly entered in Pr.00-07. All parameters can then be changed, including Pr.00-08.

The first time you can set a password directly. After successful setting of password the display will show 01 which means password protection is now effective. And all the parameters will display 0 (except Pr00-07 and Pr00-08) and cannot be modified.

Be sure to record the password for later use.

To cancel the parameter lock, set the parameter to 00 after inputting correct password

into Pr. 00-07. The password consists of min. 2 digits and max. 5 digits.



How to make the password valid again after decoding by Pr.00-07:

Method 1: Re-input original password into Pr.00-08 (Or you can enter a new password if you want to use a changed or new one).

Method 2: After rebooting, password function will be recovered.

Password Decode Flow Chart

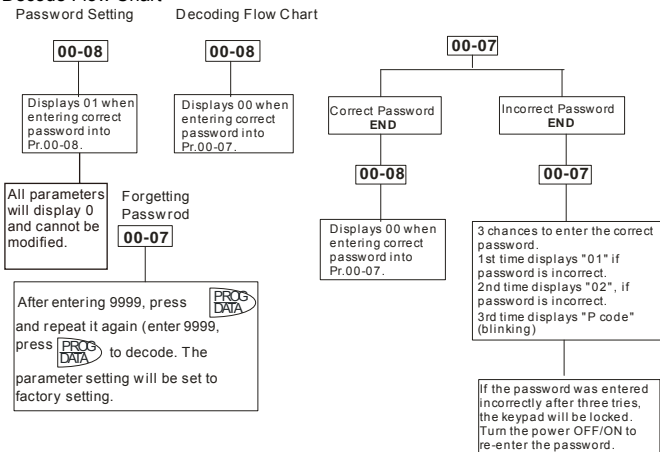

00-09 ✓Energy Saving Gain

Unit: 1

Control mode FOCPG

Factory setting: 100%

Settings 10~1000 %



When Pr.00-19 is set to 1, this parameter can be used for energy saving. The setting should be decreased when the energy saving is not well. When the motor is vibrated, the setting should be increased.

00-10 Control Method

Control mode VF VFBG SVC FOCPG TQCPG

Factory setting: 0

Settings 0 V/f control
1 V/f + Encoder (VFBG)

- 2 Sensorless vector control (SVC)
- 3 FOC vector control + Encoder (FOCPG)
- 4 Torque control + Encoder (TQCPG)

This parameter determines the control method of the AC motor drive:

Setting 0: user can design V/f ratio by requirement and control multiple motors simultaneously.

Setting 1: User can use PG card with Encoder to do close-loop speed control.

Setting 2: To have optimal control characteristic by auto-tuning.

Setting 3: To increase torque and control speed precisely. (1:1000)

Setting 4: To increase accuracy for torque control.

When Pr.00-10 is set to 3, FOCPG control diagram is shown as follows.

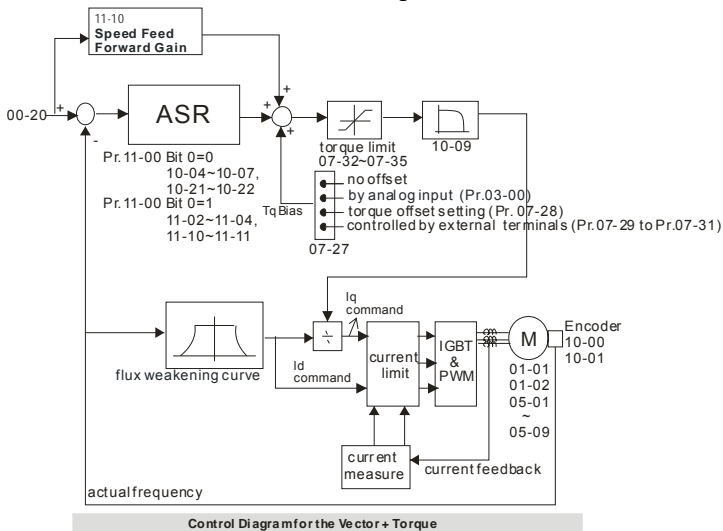

Position control diagram

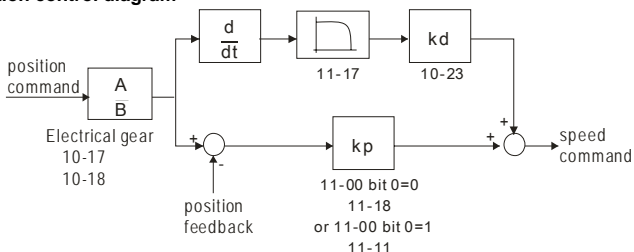

When Pr.00-10 is set to 4, TQCPG control diagram is shown as follows.

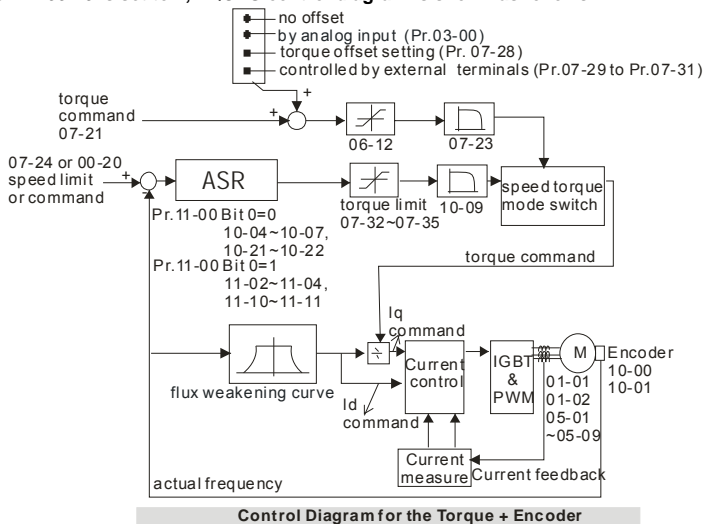

00-11 V/f Curve Selection

Control mode	VF	VFPG	Factory setting: 0
Settings	0	V/f curve determined by group 01	
	1	1.5 power curve	
	2	Square curve	

When it is set to 0, the V/f curve setting for the motor 1 is according to Pr.01-01~Pr.01-08 and Pr. 01-35~01-42 are for the motor 2.

- When setting to 1 or 2, the settings of the 2nd voltage/frequency and the 3rd voltage/frequency are invalid.

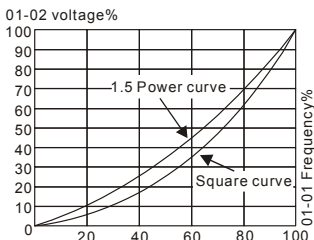

00-12 Constant/Variable Torque Selection

Control mode	VF	VFPG	SVC	FOCPG	Factory setting: 0
Settings		0	Constant Torque (150%)		
		1	Variable Torque (120%)		

- When “1” is selected, the oL level is 120% of rated drive current. All other overload ratings will not change, example: 150% of rated drive current for 60 seconds.

00-13 Optimal Acceleration/Deceleration Setting

Control mode	VF	VFPG	SVC	FOCPG	Factory setting: 0
Settings		0	Linear accel./decel.		
		1	Auto accel., linear decel.		
		2	Linear accel., auto decel.		
		3	Auto accel./decel. (auto calculate the accel./decel. time by actual load)		
		4	Stall prevention by auto accel./decel. (limited by 01-12 to 01-21)		

- It can decrease the drive's vibration during load starts and stops by setting this parameter. Also it will speed up to the setting frequency with the fastest and smoothest start-up current when it detects small torque. At deceleration, it will auto stop the drive with the fastest and the smoothest deceleration time when the regenerated voltage of the load is detected.

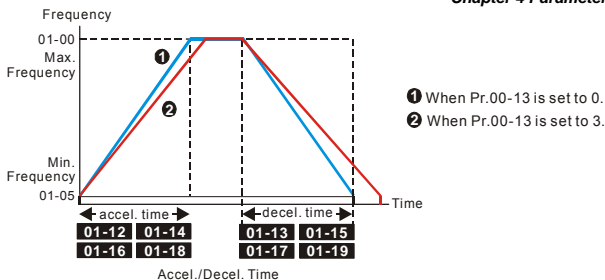
**00-14** Time Unit for Acceleration/Deceleration and S Curve

Factory setting: 0

Control mode

VF VFPG SVC FOCPCG

Settings 0 Unit: 0.01 second
1 Unit: 0.1 second

 This parameter determines the time unit for the Acceleration/Deceleration setting. Refer to Pr.01-12 ~ Pr.01-19 (accel./decel. Time 1 to 4), Pr. 01-20~Pr.01-21 (JOG accel./decel. Time) and Pr. 01-24~Pr.01-27 (S curve accel./decel. Time).

00-15 Reserved**00-16** Reserved**00-17**  Carrier Frequency

Unit: 1

Control mode



VF VFPG SVC FOCPCG TQCPG

Factory setting: 10

Settings 1~15kHz

 This parameter determinates the PWM carrier frequency of the AC motor drive.



230V/460V Series				
Models	1-5HP 0.75-3.7kW	7.5-25HP 5.5-18.5kW	30-60HP 22-45kW	75-100HP 55-75Kw
Setting Range	01~15kHz		01~09kHz	01~06kHz
Factory Setting	10kHz	9kHz	6kHz	6kHz

Carrier Frequency	Acoustic Noise	Electromagnetic Noise or Leakage Current	Heat Dissipation	Current Wave
1kHz	Significant	Minimal	Minimal	
8kHz	↑	↑	↑	
15kHz	Minimal	Significant	Significant	

-  From the table, we see that the PWM carrier frequency has a significant influence on the electromagnetic noise, AC motor drive heat dissipation, and motor acoustic noise.



00-18 Auto Voltage Regulation (AVR) Function

Control mode	VF	VFPG	SVC	FOCPG	TQCPG	Factory setting: 0
Settings		0	Enable AVR			
		1	Disable AVR			
		2	Disable AVR when deceleration stop			

-  It is used to select the AVR mode. AVR is used to regulate the output voltage to the motor. For example, if V/f curve is set to AC200V/50Hz and the input voltage is from 200 to 264VAC, the output voltage won't exceed AC200V/50Hz. If the input voltage is from 180 to 200V, the output voltage to the motor and the input voltage will be in direct proportion.
-  When setting Pr.00-18 to 1 during ramp to stop and used with auto accel./decel. function, the acceleration will be smoother and faster.
-  It is recommended to set Pr.00-18 to 0 (enable AVR) when the control mode is FOCPG or TQCPG.

00-19 Auto Energy-saving Operation

Control mode	VF	VFPG	SVC	FOCPG	Factory setting: 0
Settings		0	Disable		
		1	Enable		

-  When the Auto Energy-saving function is enabled, the drive will operate with full voltage during acceleration and deceleration. At constant speed, the AC drive will calculate the optimal output voltage value for the load. It is possible for the output voltage to be 25% below Maximum Output Voltage during auto energy-saving operation. This function should not be used with variable loads or continuous rated output loads.
-  When output frequency is constant, i.e. constant operation, the output voltage will be auto decreased with load reduction. To make the AC motor drive runs under the energy-saving with the minimum value of the product of voltage and current.

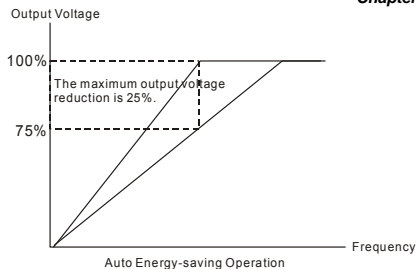
**00-20** / Source of the Master Frequency Command

Control mode	VF	VFPG	SVC	FOCPG	Factory setting: 0
Settings		0	Digital keypad (KPV-CE01)		
		1	RS-485 serial communication		
		2	External analog input (Pr. 03-00)		
		3	External UP/DOWN terminal		
		4	Pulse input without direction command (Pr.10-15 without direction)		
		5	Pulse input with direction command (Pr.10-15)		

This parameter determines the drive's master frequency source.

When it is set to 0, it will display "PU".

00-21 / Source of the Operation Command

Control mode	VF	VFPG	SVC	FOCPG	TQCPG	Factory setting: 0
Settings		0	Digital keypad (KPV-CE01)			
		1	External terminals. Keypad STOP disabled.			
		2	RS-485 serial communication (RJ-11). Keypad STOP disabled.			

When Pr.00-21 is set to 1, it also needs to set Pr.00-20 and Pr.00-21 to 0. After pressing PU key to make LED PU to be light, RUN, JOG and STOP key are valid now.

00-22 / Stop Method

Control mode	VF	VFPG	SVC	FOCPG	TQCPG	Factory setting: 0
Settings		0	Ramp to stop			
		1	Coast to stop			

 The parameter determines how the motor is stopped when the AC motor drive receives a valid stop command.

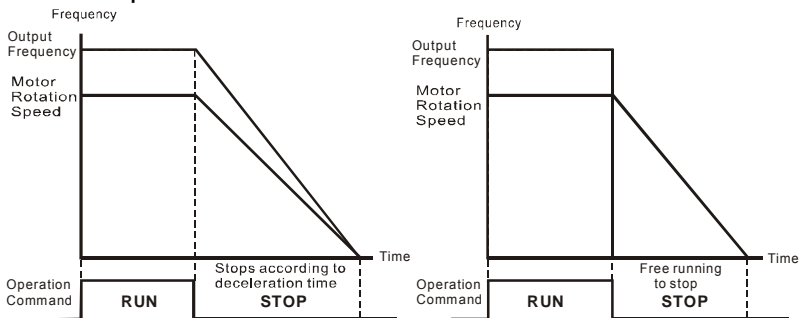

Ramp to Stop and Coast to Stop

Ramp to stop: the AC motor drive decelerates from the maximum output frequency (Pr. 01-00) to minimum output frequency (Pr. 01-09) according to the deceleration time and then stop.

Coast to stop: the AC motor drive stops the output instantly upon a STOP command and the motor free runs until it comes to a complete standstill.

(1) It is recommended to use “ramp to stop” for safety of personnel or to prevent material from being wasted in applications where the motor has to stop after the drive is stopped. The deceleration time has to be set accordingly.

(2) If the motor free running is allowed or the load inertia is large, it is recommended to select “coast to stop”. For example, blowers, punching machines and pumps.

 The stop method of the torque control is also set by Pr.00-22.

00-23 Motor Direction Control

Control mode	VF	VFPG	SVC	FOCPG	TQCPG	Factory setting: 0
Settings	0	Enable forward/reverse				
	1	Disable reverse				
	2	Disable forward				



 This parameter enables the AC motor drives to run in the forward/reverse Direction. It may be used to prevent a motor from running in a direction that would consequently injure humans or damage the equipment.

Group 1 Basic Parameters



01-00	Maximum Output Frequency					Unit: 0.01
Control mode	VF	VFPG	SVC	FOCPG	TQCPG	Factory setting: 60.00/50.00
	Settings		50.0 to 600.00Hz			

-  **This parameter determines the AC motor drive's Maximum Output Frequency. All the AC motor drive frequency command sources (analog inputs 0 to +10V, 4 to 20mA and -10V to +10V) are scaled to correspond to the output frequency range.**

01-01	1st Output Frequency Setting 1					
01-35	1st Output Frequency Setting 2					Unit: 0.01
Control mode	VF	VFPG	SVC	FOCPG	TQCPG	Factory setting: 60.00/50.00
	Settings		0.00~600.00Hz			

-  **These are for the base frequency and motor rated frequency.**
-  **This value should be set according to the rated frequency of the motor as indicated on the motor nameplate. If the motor is 60Hz, the setting should be 60Hz. If the motor is 50Hz, it should be set to 50Hz.**
-  **Pr.01-35 is used for the application occasion that uses double base motor.**

01-02	1st Output Voltage Setting 1					
01-36	1st Output Voltage Setting 2					Unit: 0.1
Control mode	VF	VFPG	SVC	FOCPG	TQCPG	
	Settings	230V series	0.1 to 255.0V			Factory Setting: 220.0
		460V series	0.1 to 510.0V			Factory Setting: 440.0

-  **These are for the base frequency and motor rated frequency.**
-  **This value should be set according to the rated voltage of the motor as indicated on the motor nameplate. If the motor is 220V, the setting should be 220.0. If the motor is 200V, it should be set to 200.0.**
-  **There are many motor types in the market and the power system for each country is also difference. The economic and convenience method to solve this problem is to install the AC motor drive. There is no problem to use with the different voltage and frequency and also can amplify the original characteristic and life of the motor.**

01-03	2nd Output Frequency Setting 1				Unit: 0.01
Control mode	VF	VFPG	Factory setting: 0.50		
	Settings	0.00~600.00Hz			
01-04	2nd Output Voltage Setting 1				Unit: 0.1
Control mode	VF	VFPG	Factory Setting: 5.0		
	Settings	230V series	0.1 to 255.0V	Factory Setting: 10.0	
		460V series	0.1 to 510.0V		
01-37	2nd Output Frequency Setting 2				Unit: 0.01
Control mode	VF	VFPG	Factory setting: 0.50		
	Settings	0.00~600.00Hz			
01-38	2nd Output Voltage Setting 2				Unit: 0.1
Control mode	VF	VFPG	Factory Setting: 5.0		
	Settings	230V series	0.1 to 255.0V	Factory Setting: 10.0	
		460V series	0.1 to 510.0V		
01-05	3rd Output Frequency Setting 1				Unit: 0.01
Control mode	VF	VFPG	Factory Setting: 0.50		
	Settings	0.00~600.00Hz			
01-06	3rd Output Voltage Setting 1				Unit: 0.1
Control mode	VF	VFPG	Factory Setting: 5.0		
	Settings	230V series	0.1 to 255.0V	Factory Setting: 10.0	
		460V series	0.1 to 510.0V		
01-39	3rd Output Frequency Setting 2				Unit: 0.01
Control mode	VF	VFPG	Factory Setting: 0.50		
	Settings	0.00~600.00Hz			
01-40	3rd Output Voltage Setting 2				Unit: 0.1
Control mode	VF	VFPG	Factory Setting: 5.0		
	Settings	230V series	0.1 to 255.0V	Factory Setting: 10.0	
		460V series	0.1 to 510.0V		
01-07	4th Output Frequency Setting 1				Unit: 0.01
Control mode	VF	VFPG	SVC	FOCPG	Factory Setting: 0.00
	Settings	0.00~600.00Hz			

01-08 4th Output Voltage Setting 1 Unit: 0.1





Control mode	VF	VFPG		
Settings	230V series	0.1 to 255.0V	Factory Setting: 0.0	
	460V series	0.1 to 510.0V	Factory Setting: 0.0	

01-41 4th Output Frequency Setting 2 Unit: 0.01

Control mode	VF	VFPG	SVC	FOCPG	TQCPG	Factory Setting: 0.00
Settings	0.00~600.00Hz					

01-42 4th Output Voltage Setting 2 Unit: 0.1

Control mode	VF	VFPG		
Settings	230V series	0.1 to 255.0V	Factory Setting: 0.0	
	460V series	0.1 to 510.0V	Factory Setting: 0.0	

-  **V/f curve setting is usually set by the motor's allowable loading characteristics. Pay special attention to the motor's heat dissipation, dynamic balance, and bearing lubricity, if the loading characteristics exceed the loading limit of the motor.**
-  **For the V/f curve setting, it should be Pr.01-01 \geq Pr.01-03 \geq Pr.01-05 \geq Pr.01-07. There is no limit for the voltage setting, but a high voltage at the low frequency may cause motor damage, overheat, stall prevention or over-current protection. Therefore, please use the low voltage at the low frequency to prevent motor damage.**
-  **Pr.01-35 to Pr.01-42 is the V/f curve for the motor 2. When multi-function input terminals Pr.02-01 to Pr.02-14 is set to 14 and enabled or switch to the Δ -connection, the AC motor drive will act as the 2nd V/f curve.**
-  **The V/f curve for the motor 1 is shown as follows. The V/f curve for the motor 2 can be deduced from it.**

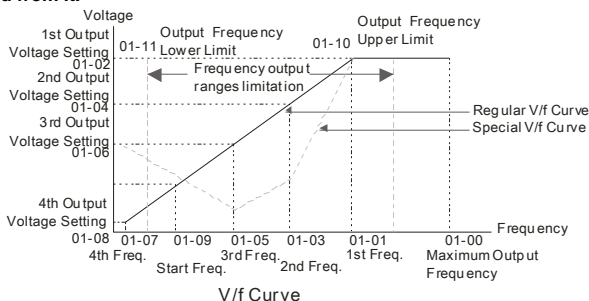

Control mode	VF	VFPG	SVC	FOCPG
--------------	----	------	-----	-------

Factory Setting: 0.50

Settings	0.00~600.00Hz
----------	---------------

When start frequency is higher than the min. output frequency, drives' output will be from start frequency to the setting frequency. Please refer to the following diagram for details.

Fcmd=frequency command,

Fstart=start frequency (Pr.01-09),

fstart=actual start frequency of drive,

Fmin=4th output frequency setting (Pr.01-07/Pr.01-41),

Flow=output frequency lower limit (Pr.01-11)

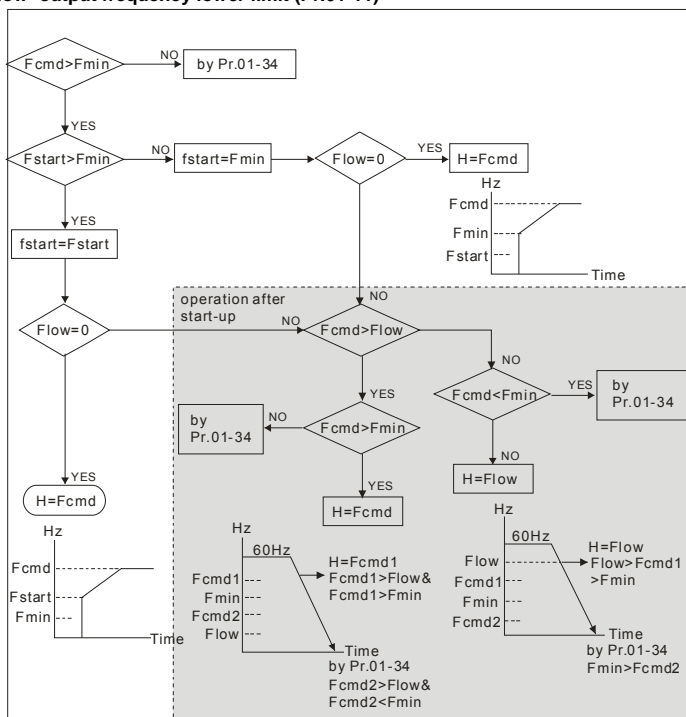

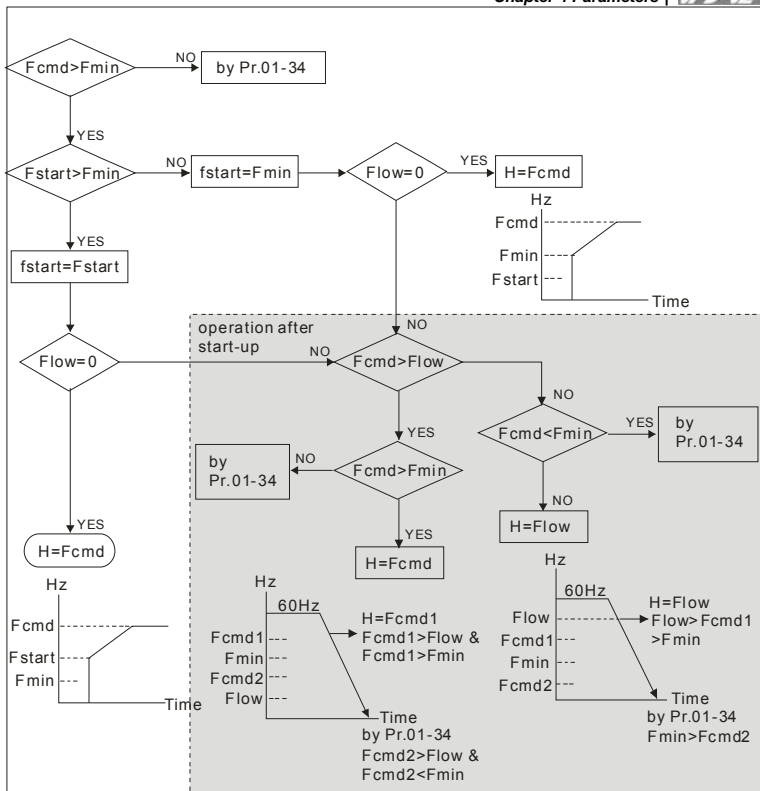
**01-10** Output Frequency Upper Limit

Unit: 0.01

Control mode VF VFG SVC FOCPG

Factory Setting: 600.00

Settings 0.00~600.00Hz

01-11 Output Frequency Lower Limit

Unit: 0.01

Control mode VF VFG SVC FOCPG

Factory Setting: 0.00

Settings 0.00~600.00Hz

The upper/lower output frequency setting is used to limit the actual output frequency. If the frequency setting is higher than the upper limit, it will run with the upper limit frequency. If output frequency lower than output frequency lower limit and frequency

setting is higher than min. frequency, it will run with lower limit frequency. The upper limit frequency should be set to be higher than the lower limit frequency.

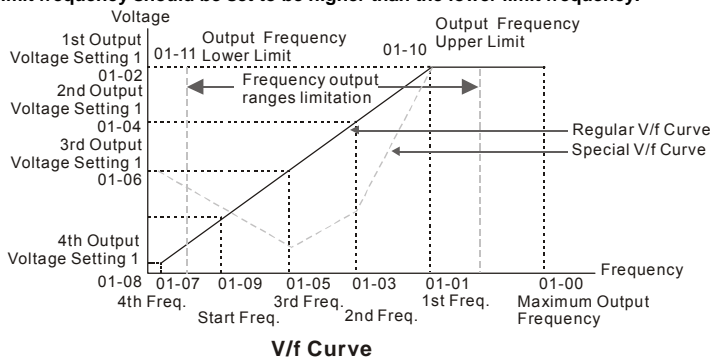

01-12	↗ Accel. Time 1	Unit: 0.1/0.01
01-13	↘ Decel. Time 1	Unit: 0.1/0.01
01-14	↗ Accel. Time 2	Unit: 0.1/0.01
01-15	↘ Decel. Time 2	Unit: 0.1/0.01
01-16	↗ Accel. Time 3	Unit: 0.1/0.01
01-17	↘ Decel. Time 3	Unit: 0.1/0.01
01-18	↗ Accel. Time 4	Unit: 0.1/0.01
01-19	↘ Decel. Time 4	Unit: 0.1/0.01

Control mode	VF	VFPG	SVC	FOCPG	Factory Setting: 10.00/10.0
Settings	0.00~600.00 sec/0.00~6000.0 sec				



01-20	↗ JOG Acceleration Time	Unit: 0.1/0.01
01-21	↘ JOG Deceleration Time	Unit: 0.1/0.01

Control mode	VF	VFPG	SVC	FOCPG	Factory Setting: 1.00/1.0
Settings	0.00~600.00 sec/0.00~6000.0 sec				

The Acceleration Time is used to determine the time required for the AC motor drive to ramp from 0Hz to Maximum Output Frequency (Pr.01-00).



The Deceleration Time is used to determine the time require for the AC motor drive to decelerate from the Maximum Output Frequency (Pr.01-00) down to 0Hz.

The Acceleration/Deceleration Time is invalid when using Pr.00-13 Optimal Acceleration/Deceleration Setting.

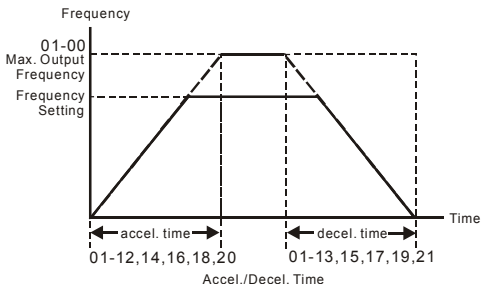

-  The Acceleration/Deceleration Time 1, 2, 3, 4 are selected according to the Multi-function Input Terminals settings. See Pr.02-01 to Pr.02-30 for details.
-  When enabling torque limit and stall prevention function, actual accel./decel. time will longer than the above action time.



01-22	↗ JOG Frequency				Unit: 0.01	
Control mode	VF	VFG	SVC	FOCPG	TQCPG	Factory Setting: 6.00
Settings	0.00~600.00Hz					

-  Both external terminal JOG and key “JOG” on the keypad can be used. When the jog command is ON, the AC motor drive will accelerate from 0Hz to jog frequency (Pr.01-22). When the jog command is OFF, the AC motor drive will decelerate from Jog Frequency to zero. The used Accel./Decel. time is set by the Jog Accel./Decel. time (Pr.01-20, Pr.01-21).
-  The JOG command can't be executed when the AC motor drive is running. In the same way, when the JOG command is executing, other operation commands are invalid except forward/reverse commands and STOP key on the digital keypad.

01-23	↗ 1st/4th Accel./decel. Frequency				Unit: 0.01
Control mode	VF	VFG	SVC	FOCPG	Factory Setting: 0.00
Settings	0.00~600.00Hz				

-  This parameter selects the frequency point for transition from acceleration/deceleration time 1 to acceleration/deceleration time 4.
-  The transition from acceleration/deceleration time 1 to acceleration/deceleration time 4, may also be enabled by the external terminals (Pr. 02-01 to 02-08). The external terminal has priority over Pr. 01-23.

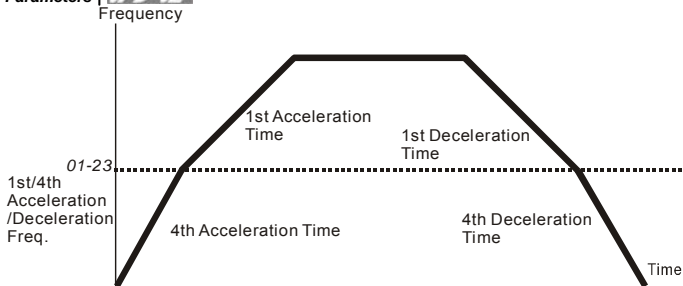

1st/4th Acceleration/Deceleration Switching

01-24	✓	S-curve for Acceleration Departure Time 1	Unit: 0.1/0.01		
01-25	✓	S-curve for Acceleration Arrival Time 2	Unit: 0.1/0.01		
01-26	✓	S-curve for Deceleration Departure Time 1	Unit: 0.1/0.01		
01-27	✓	S-curve for Deceleration Arrival Time 2	Unit: 0.1/0.01		
Control mode	VF	VFPG	SVC	FOCPG	Factory Setting: 0.2/0.0
Settings	0.00~25.00 sec / 0.00~250.0 sec				

It is used to give the smoothest transition between speed changes. The accel./decel. curve can adjust the S-curve of the accel./decel. When it is enabled, the drive will have different accel./decel. curve by the accel./decel. time.

The S-curve function is disabled when accel./decel. time is set to 0.

**When the selected accel. time \geq Pr.01-24 and Pr.01-25,
The Actual Accel. Time = selected accel. Time + (Pr.01-24 + Pr.01-25)/2**

**When the selected decel. time \geq Pr.01-26 and Pr.01-27,
The Actual Decel. Time = selected decel. Time + (Pr.01-26 + Pr.01-27)/2**

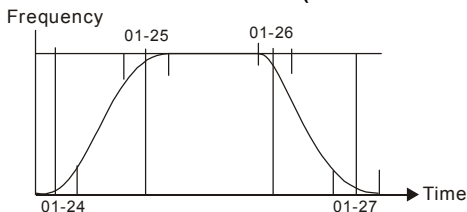





01-28	Skip Frequency 1 (upper limit)	Unit: 0.01
01-29	Skip Frequency 1 (lower limit)	Unit: 0.01
01-30	Skip Frequency 2 (upper limit)	Unit: 0.01

01-31	Skip Frequency 2 (lower limit)	Unit: 0.01
01-32	Skip Frequency 3 (upper limit)	Unit: 0.01
01-33	Skip Frequency 3 (lower limit)	Unit: 0.01
Control mode	VF VFPG SVC FOCPG	Factory Setting: 0.00
	Settings 0.00~600.00Hz	

-  **These parameters are used to set the skip frequency of the AC drive. The skip frequencies are useful when a motor has vibration at a specific frequency bandwidth. By skipping this frequency, the vibration will be avoided.**

01-34	Mode Selection when Frequency < Fmin			Factory Setting: 0
Control mode	VF	VFPG	SVC	FOCPG
	Settings	0	Output Waiting	
		1	Zero-speed operation	
		2	Fmin (4th output frequency setting)	

-  **When the frequency is less than Fmin (Pr.01-07 or Pr.01-41), it will operate by this parameter.**
-  **When it is set to 0, the AC motor drive will be in waiting mode without voltage output from terminals U/V/W.**
-  **When setting 1, it will execute DC brake by Vmin(Pr.01-08 and Pr.01-42) in V/f, VFPG and SVC modes.**
-  **When it is set to 2, the AC motor drive will run by Fmin (Pr.01-07, Pr.01-41) and Vmin (Pr.01-08, Pr.01-42) in V/f, VFPG, SVC and FOCPG modes.**
-  **In V/f, VFPG and SVC modes**

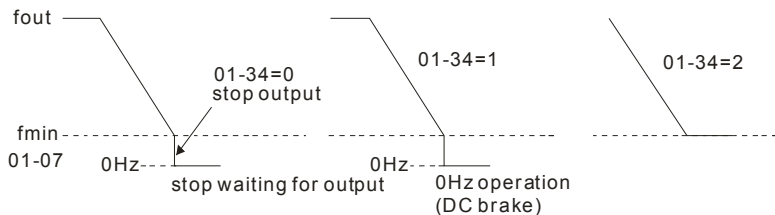

 In FOC PG mode, when Pr.01-34 is set to 2, it will act according Pr.01-34 setting.

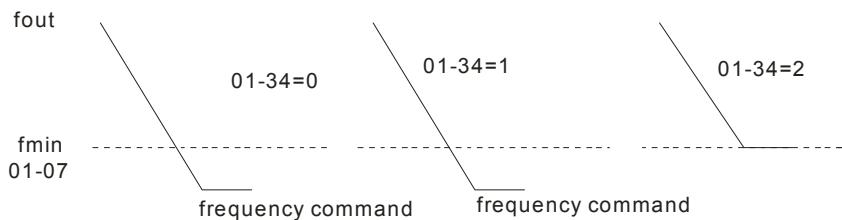

Group 2 Digital Input/Output Parameters

02-00 2-wire/3-wire Operation Control

Control mode	VF	VFGP	SVC	FOCPG	TQCPG	Factory setting: 0
Settings	0		FWD/STOP, REV/STOP			
	1		FWD/STOP, REV/STOP (Line Start Lockout)			
	2		RUN/STOP, REV/FWD			
	3		RUN/STOP, REV/FWD (Line Start Lockout)			
	4		3-wire (momentary push button)			
	5		3-wire (momentary push button and Line Start Lockout)			

 **Three of the six methods include a “Line Start Lockout” feature. When line start lockout is enabled, the drive will not run once applying the power. The Line Start Lockout feature doesn’t guarantee the motor will never start under this condition. It is possible the motor may be set in motion by a malfunctioning switch.**

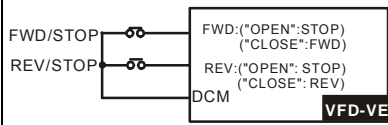
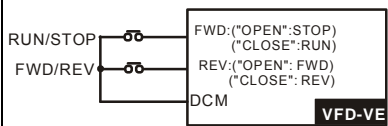
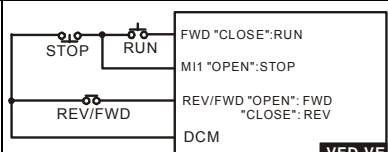
02-00	Control Circuits of the External Terminal
0, 1 2-wire operation control (1) FWD/STOP REV/STOP	
2, 3 2-wire operation control (2) RUN/STOP REV/FWD	
4, 5 3-wire operation control	

02-01 Multi-Function Input Command 1 (MI1)

Factory Setting: 1

02-02 Multi-Function Input Command 2 (MI2)

Factory Setting: 2





02-03 Multi-Function Input Command 3 (MI3)

Factory Setting: 3

02-04	Multi-Function Input Command 4 (MI4)	Factory Setting: 4
02-05	Multi-Function Input Command 5 (MI5)	Factory Setting: 0
02-06	Multi-Function Input Command 6 (MI6)	Factory Setting: 0
02-23	Multi-Function Input Command 7 (MI7)	Factory Setting: 0
02-24	Multi-Function Input Command 8 (MI8)	Factory Setting: 0
02-25	Multi-Function Input Command 9 (MI9)	Factory Setting: 0
02-26	Multi-Function Input Command 10 (MIA)	Factory Setting: 0
02-27	Multi-Function Input Command 11 (MIB)	Factory Setting: 0
02-28	Multi-Function Input Command 12	Factory Setting: 0
02-29	Multi-Function Input Command 13	Factory Setting: 0
02-30	Multi-Function Input Command 14	Factory Setting: 0
Settings	0-50	

Settings	Control Mode				
	VF	VFPG	SVC	FOCPG	TQCPG
0: no function	<input type="radio"/>	<input type="radio"/>	<input type="radio"/>	<input type="radio"/>	<input type="radio"/>
1: multi-step speed command 1/multi-step position command 1	<input type="radio"/>	<input type="radio"/>	<input type="radio"/>	<input type="radio"/>	
2: multi-step speed command 2/ multi-step position command 2	<input type="radio"/>	<input type="radio"/>	<input type="radio"/>	<input type="radio"/>	
3: multi-step speed command 3/ multi-step position command 3	<input type="radio"/>	<input type="radio"/>	<input type="radio"/>	<input type="radio"/>	
4: multi-step speed command 4/ multi-step position command 4	<input type="radio"/>	<input type="radio"/>	<input type="radio"/>	<input type="radio"/>	
5: Reset	<input type="radio"/>	<input type="radio"/>	<input type="radio"/>	<input type="radio"/>	<input type="radio"/>
6: JOG command	<input type="radio"/>	<input type="radio"/>	<input type="radio"/>	<input type="radio"/>	
7: acceleration/deceleration speed inhibit	<input type="radio"/>	<input type="radio"/>	<input type="radio"/>	<input type="radio"/>	
8: the 1st, 2nd acceleration/deceleration time selection	<input type="radio"/>	<input type="radio"/>	<input type="radio"/>	<input type="radio"/>	
9: the 3rd, 4th acceleration/deceleration time selection	<input type="radio"/>	<input type="radio"/>	<input type="radio"/>	<input type="radio"/>	
10: EF input (07-36)	<input type="radio"/>	<input type="radio"/>	<input type="radio"/>	<input type="radio"/>	<input type="radio"/>
11: B.B. input	<input type="radio"/>	<input type="radio"/>	<input type="radio"/>	<input type="radio"/>	<input type="radio"/>
12: Output stop	<input type="radio"/>	<input type="radio"/>	<input type="radio"/>	<input type="radio"/>	<input type="radio"/>

Settings	Control Mode				
	VF	VFPG	SVC	FOCPG	TQCPG
13: cancel the setting of the optimal acceleration/deceleration time	<input type="radio"/>	<input type="radio"/>	<input type="radio"/>	<input type="radio"/>	
14: switch between drive settings 1 and 2	<input type="radio"/>	<input type="radio"/>	<input type="radio"/>	<input type="radio"/>	
15: operation speed command form AVI	<input type="radio"/>	<input type="radio"/>	<input type="radio"/>	<input type="radio"/>	
16: operation speed command form ACI	<input type="radio"/>	<input type="radio"/>	<input type="radio"/>	<input type="radio"/>	
17: operation speed command form AUI	<input type="radio"/>	<input type="radio"/>	<input type="radio"/>	<input type="radio"/>	
18: Emergency Stop (07-36)	<input type="radio"/>	<input type="radio"/>	<input type="radio"/>	<input type="radio"/>	<input type="radio"/>
19: Digital Up command	<input type="radio"/>	<input type="radio"/>	<input type="radio"/>	<input type="radio"/>	
20: Digital Down command	<input type="radio"/>	<input type="radio"/>	<input type="radio"/>	<input type="radio"/>	
21: PID function disabled	<input type="radio"/>	<input type="radio"/>	<input type="radio"/>	<input type="radio"/>	
22: clear counter	<input type="radio"/>	<input type="radio"/>	<input type="radio"/>	<input type="radio"/>	<input type="radio"/>
23: input the counter value (multi-function input command 6)	<input type="radio"/>	<input type="radio"/>	<input type="radio"/>	<input type="radio"/>	<input type="radio"/>
24: FWD JOG command	<input type="radio"/>	<input type="radio"/>	<input type="radio"/>	<input type="radio"/>	
25: REV JOG command	<input type="radio"/>	<input type="radio"/>	<input type="radio"/>	<input type="radio"/>	
26: TQCPG/FOCPG mode selection	<input type="radio"/>	<input type="radio"/>	<input type="radio"/>	<input type="radio"/>	<input type="radio"/>
27: ASR1/ASR2 selection	<input type="radio"/>	<input type="radio"/>	<input type="radio"/>	<input type="radio"/>	
28: Emergency stop (EF1)	<input type="radio"/>	<input type="radio"/>	<input type="radio"/>	<input type="radio"/>	<input type="radio"/>
29: Signal confirmation for Y-connection	<input type="radio"/>	<input type="radio"/>	<input type="radio"/>	<input type="radio"/>	
30: Signal confirmation for connection	<input type="radio"/>	<input type="radio"/>	<input type="radio"/>	<input type="radio"/>	
31: High torque bias (by Pr.07-29)	<input type="radio"/>	<input type="radio"/>	<input type="radio"/>	<input type="radio"/>	<input type="radio"/>
32: Middle torque bias (by Pr.07-30)	<input type="radio"/>	<input type="radio"/>	<input type="radio"/>	<input type="radio"/>	<input type="radio"/>
33: Low torque bias (by Pr.07-31)	<input type="radio"/>	<input type="radio"/>	<input type="radio"/>	<input type="radio"/>	<input type="radio"/>
34: Enable multi-step position control		<input type="radio"/>		<input type="radio"/>	
35: Enable position control	<input type="radio"/>		<input type="radio"/>	<input type="radio"/>	
36: Enable multi-step position learning function (valid at stop)		<input type="radio"/>		<input type="radio"/>	
37: Enable pulse position input command	<input type="radio"/>	<input type="radio"/>	<input type="radio"/>	<input type="radio"/>	
38: Disable write EEPROM function	<input type="radio"/>	<input type="radio"/>	<input type="radio"/>	<input type="radio"/>	<input type="radio"/>
39: Torque command direction					<input type="radio"/>
40: Force stop	<input type="radio"/>	<input type="radio"/>	<input type="radio"/>	<input type="radio"/>	<input type="radio"/>
41: Serial position clock				<input type="radio"/>	
42: Serial position input				<input type="radio"/>	
43: Analog input resolution selection				<input type="radio"/>	
44: Enable initial reel diameter	<input type="radio"/>	<input type="radio"/>	<input type="radio"/>	<input type="radio"/>	<input type="radio"/>
45: Reset initial reel diameter 1	<input type="radio"/>	<input type="radio"/>	<input type="radio"/>	<input type="radio"/>	<input type="radio"/>
46: Reset initial reel diameter 2	<input type="radio"/>	<input type="radio"/>	<input type="radio"/>	<input type="radio"/>	<input type="radio"/>
47: Reset PID control integration of tension	<input type="radio"/>	<input type="radio"/>	<input type="radio"/>	<input type="radio"/>	
48: Mechanical Gear Ratio Switch				<input type="radio"/>	<input type="radio"/>
49: Enable Drive	<input type="radio"/>	<input type="radio"/>	<input type="radio"/>	<input type="radio"/>	<input type="radio"/>
50: Reserved					

-  This parameter selects the functions for each multi-function terminal.
-  The terminals of Pr.02-23~Pr.02-27 are virtual and set as MI7~MIB when using with optional card EMV-APP01
-  If Pr.02-00 is set to 3-wire operation control. Terminal MI1 is needed for the 3rd wire position. Therefore, MI1 is not allowed for any other operation.
-  Multi-function input commands 7-14 are the extension terminals of Pr.02-01 to Pr.02-06. There are 14 terminals but the terminals 7-14 are virtual terminals and you can set the

status of bit 8-15 of Pr.02-10 to ON or OFF by KPV-CE01 or communication.

Summary of function settings (Take the normally open contact for example, ON: contact is closed, OFF: contact is open)

Settings	Functions	Descriptions
0	No Function	
1	Multi-step speed command 1/multi-step position command 1	15 step speeds could be conducted through the digital statuses of the 4 terminals, and 17 in total if the master speed and JOG are included. (Refer to Pr. 04-00~04-29)
2	Multi-step speed command 2/ multi-step position command 2	
3	Multi-step speed command 3/ multi-step position command 3	
4	Multi-step speed command 4/ multi-step position command 4	
5	Reset	After the error of the drive is eliminated, use this terminal to reset the drive.
6	JOG Command	JOG operation
7	Acceleration/deceleration Speed Inhibit	When this function is enabled, acceleration and deceleration is stopped and the AC motor drive start to accel./decel. from the inhibit point.
8	The 1 st , 2 nd acceleration or deceleration time selection	The acceleration/deceleration time of the drive could be selected from this function or the digital statuses of the terminals; there are 4 acceleration/deceleration speeds in total for selection.
9	The 3 rd , 4 th acceleration or deceleration time selection	
10	EF Input	External fault input terminal
11	B.B. Input	When this contact is ON, output of the drive will be cut off immediately, and the motor will be free run and display B.B. signal. Refer to Pr.07-08 for details.
12	Output Stop	If this contact is ON, output of the drive will be cut off immediately, and the motor will then be free run. And once it is turned to OFF, the drive will accelerate to the setting frequency.
13	Cancel the setting of the optimal accel./decel. time	Before using this function, Pr.00-13 should be set to 01/02/03/04 first. When this function is enabled, OFF is for auto mode and

Settings	Functions	Descriptions
		ON is for linear accel./decel.
14	Switch between drive settings 1 and 2	When the contact is ON: use the motor 2 parameters. OFF: use the motor 1 parameters.
15	Operation speed command form AVI	When the contact is ON, the source of the frequency will force to be AVI. (If the operation speed commands are set to AVI, ACI and AUI at the same time. The priority is AVI > ACI > AUI)
16	Operation speed command form ACI	When the contact is ON, the source of the frequency will force to be ACI. (If the operation speed commands are set to AVI, ACI and AUI at the same time. The priority is AVI > ACI > AUI)
17	Operation speed command form AUI	When this function is enabled, the source of the frequency will force to be AUI. (If the operation speed commands are set to AVI, ACI and AUI at the same time. The priority is AVI > ACI > AUI)
18	Emergency Stop (07-36)	When the contact is ON, the drive will ramp to stop by Pr.07-36 setting.
19	Digital Up command	When the contact is ON, the frequency will be increased and decreased. If this function keeps ON, the frequency will be increased/decreased by Pr.02-07/Pr.02-08.
20	Digital Down command	
21	PID function disabled	When the contact is ON, the PID function is disabled.
22	Clear counter	When the contact is ON, it will clear current counter value and display "0". Only when this function is disabled, it will keep counting upward.
23	Input the counter value (multi-function input command 6)	The counter value will increase 1 once the contact is ON. It needs to be used with Pr.02-16.
24	FWD JOG command	When the contact is ON, the drive will execute forward Jog command.
25	REV JOG command	When the contact is ON the drive will execute reverse Jog command.
26	TQCPG/FOCPG mode selection	When the contact is ON: TQCPG mode. When the contact is OFF: FOCPG mode.

Settings	Functions	Descriptions
		<p> RUN/STOP command Multi-function input terminal is set to 26 (torque/speed mode switch) 03-00-03=1 (AVI/AUI/ACI is frequency command) 03-00-03=2 (AVI/AUI/ACI is torque command) control mode speed command, speed limit, speed command, speed limit torque limit, torque command, torque limit, torque command speed control, torque control, speed control, torque control, speed control (decel. to stop) </p> <p> Switching timing for torque/speed control (00-10=3/4, multi-function input terminal is set to 26) </p>
27	ASR1/ASR2 selection	When the contact is ON: speed will be adjusted by ASR 2 setting. OFF: speed will be adjusted by ASR 1 setting. Refer to Pr.10-08 for details.
28	Emergency stop (EF1)	When the contact is ON, the drive will execute emergency stop. (it will have fault code record)
29	Signal confirmation for Y-connection	When is the contact is ON, the drive will operate by 1st V/f.
30	Signal confirmation for Δ-connection	When the contact is ON, the drive will operate by 2nd V/f.
31	High torque bias (by Pr.07-29)	Refer to Pr.07-27~07-31 for details.
32	Middle torque bias (by Pr.07-30)	
33	Low torque bias (by Pr.07-31)	
34	Enable multi-step position control	When the contact is ON, the corresponding 15-step speed for the multi-function inputs 1-4 will be 15 positions. (Refer to Pr.04-15 to Pr.04-29)

Settings	Functions	Descriptions
		<p>The figure consists of two timing diagrams. The top diagram shows a sequence of speed mode, position mode, and speed mode. It includes signals for Run, MI=d35, MI=d34, MI=d1, MI=d2, MI=d3, MI=d4, and output frequency. Key events are marked: 10-19 position (Home), 04-27 multi-position 13, 04-26 multi-position 12, and 04-11 12th step speed frequency. The bottom diagram shows a similar sequence but with Master frequency and Output frequency signals. Key events are marked: 04-12 13th step speed frequency, 04-27 multi-position 13, and 04-26 multi-position 12.</p>
35	Enable position control	When the contact is ON, the AC motor drive will start to execute internal position control by Pr.10-19. The decel. time of positioning is decided by Pr.10-24 and the positioning direction is by the motor direction.

Settings	Functions	Descriptions
		<p>The figure consists of two timing diagrams. The top diagram shows a single step where the output frequency ramps down (labeled 10-24) and the PG feedback signal (labeled 10-00, 10-01) ramps up (labeled 10-19) as the motor decelerates. The bottom diagram shows two steps: the first step decelerates and then the motor starts again (RUN), followed by a second step where the output frequency ramps down and the PG feedback ramps up.</p>
36	Enable multi-step position learning function (valid at stop)	When the contact is ON, it will select the corresponding multi-position by the ON/OFF status of multi-function inputs 1-4 and written the current motor position into the corresponding multi-position.

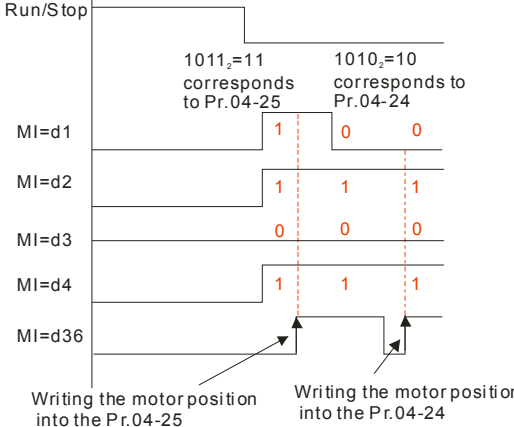
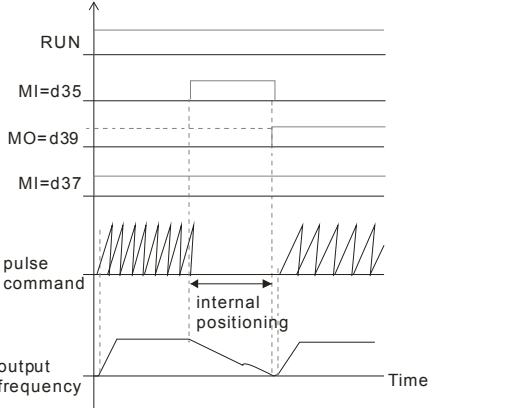
Settings	Functions	Descriptions
		<p>Run/Stop</p>  <p>1011₂=11 corresponds to Pr.04-25</p> <p>1010₂=10 corresponds to Pr.04-24</p> <p>MI=d1</p> <p>MI=d2</p> <p>MI=d3</p> <p>MI=d4</p> <p>MI=d36</p> <p>Writing the motor position into the Pr.04-25</p> <p>Writing the motor position into the Pr.04-24</p>
37	Enable pulse position input command	<p>When Pr.00-20 is set to 4 or 5 and this contact is ON, the input pulse of PG card is position command. When using this function, it is recommended to set Pr.10-23 to 0.</p> <p>Example: When it is used with MI=d35 for returning home, please refer to the following diagram.</p>  <p>RUN</p> <p>MI=d35</p> <p>MO=d39</p> <p>MI=d37</p> <p>pulse command</p> <p>output frequency</p> <p>Time</p> <p>internal positioning</p>
38	Disable write EEPROM function	When this contact is ON, you can't write into EEPROM.
39	Torque command direction	When the torque command source is AVI or ACI and this contact is ON, it is negative torque.

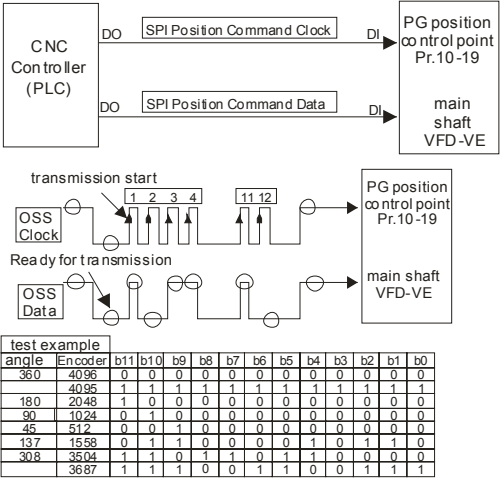
Settings	Functions	Descriptions																																																																																																																																									
40	Force stop	When this contact is ON during operation, the drive will free run to stop.																																																																																																																																									
41	Serial position clock	The position method of the main shaft: When using setting 41 and setting 42, it needs to use with 2 input terminals for multi-position control.																																																																																																																																									
42	Serial position input	 <p>transmission start</p> <p>OSS Clock</p> <p>Ready for transmission</p> <p>OSS Data</p> <p>PG position control point Pr.10-19</p> <p>main shaft VFD-VE</p> <table border="1"> <thead> <tr> <th colspan="11">test example</th> </tr> <tr> <th>angle</th> <th>Encoder</th> <th>b11</th> <th>b10</th> <th>b9</th> <th>b8</th> <th>b7</th> <th>b6</th> <th>b5</th> <th>b4</th> <th>b3</th> <th>b2</th> <th>b1</th> <th>b0</th> </tr> </thead> <tbody> <tr> <td>360</td> <td>4096</td> <td>0</td> <td>0</td> <td>0</td> <td>0</td> <td>0</td> <td>0</td> <td>0</td> <td>0</td> <td>0</td> <td>0</td> <td>0</td> <td>0</td> </tr> <tr> <td></td> <td>4095</td> <td>1</td> <td>1</td> <td>1</td> <td>1</td> <td>1</td> <td>1</td> <td>1</td> <td>1</td> <td>1</td> <td>1</td> <td>1</td> <td>1</td> </tr> <tr> <td>180</td> <td>2048</td> <td>1</td> <td>0</td> <td>0</td> <td>0</td> <td>0</td> <td>0</td> <td>0</td> <td>0</td> <td>0</td> <td>0</td> <td>0</td> <td>0</td> </tr> <tr> <td>90</td> <td>1024</td> <td>0</td> <td>1</td> <td>0</td> <td>0</td> <td>0</td> <td>0</td> <td>0</td> <td>0</td> <td>0</td> <td>0</td> <td>0</td> <td>0</td> </tr> <tr> <td>45</td> <td>512</td> <td>0</td> <td>0</td> <td>1</td> <td>0</td> <td>0</td> <td>0</td> <td>0</td> <td>0</td> <td>0</td> <td>0</td> <td>0</td> <td>0</td> </tr> <tr> <td>137</td> <td>1558</td> <td>0</td> <td>1</td> <td>1</td> <td>0</td> <td>0</td> <td>0</td> <td>0</td> <td>1</td> <td>0</td> <td>1</td> <td>1</td> <td>0</td> </tr> <tr> <td>308</td> <td>3504</td> <td>1</td> <td>1</td> <td>0</td> <td>1</td> <td>1</td> <td>0</td> <td>1</td> <td>1</td> <td>0</td> <td>0</td> <td>0</td> <td>0</td> </tr> <tr> <td></td> <td>3687</td> <td>1</td> <td>1</td> <td>1</td> <td>0</td> <td>0</td> <td>1</td> <td>1</td> <td>0</td> <td>0</td> <td>1</td> <td>1</td> <td>1</td> </tr> </tbody> </table>	test example											angle	Encoder	b11	b10	b9	b8	b7	b6	b5	b4	b3	b2	b1	b0	360	4096	0	0	0	0	0	0	0	0	0	0	0	0		4095	1	1	1	1	1	1	1	1	1	1	1	1	180	2048	1	0	0	0	0	0	0	0	0	0	0	0	90	1024	0	1	0	0	0	0	0	0	0	0	0	0	45	512	0	0	1	0	0	0	0	0	0	0	0	0	137	1558	0	1	1	0	0	0	0	1	0	1	1	0	308	3504	1	1	0	1	1	0	1	1	0	0	0	0		3687	1	1	1	0	0	1	1	0	0	1	1	1
test example																																																																																																																																											
angle	Encoder	b11	b10	b9	b8	b7	b6	b5	b4	b3	b2	b1	b0																																																																																																																														
360	4096	0	0	0	0	0	0	0	0	0	0	0	0																																																																																																																														
	4095	1	1	1	1	1	1	1	1	1	1	1	1																																																																																																																														
180	2048	1	0	0	0	0	0	0	0	0	0	0	0																																																																																																																														
90	1024	0	1	0	0	0	0	0	0	0	0	0	0																																																																																																																														
45	512	0	0	1	0	0	0	0	0	0	0	0	0																																																																																																																														
137	1558	0	1	1	0	0	0	0	1	0	1	1	0																																																																																																																														
308	3504	1	1	0	1	1	0	1	1	0	0	0	0																																																																																																																														
	3687	1	1	1	0	0	1	1	0	0	1	1	1																																																																																																																														
43	Analog input resolution selection	Refer to Pr.10-25 for details.																																																																																																																																									
44	Enable Reset initial reel diameter	When the drive is at stop and it is in tension control mode, it needs to set 3-step initial reel by the digital status of terminals 45 and 46 (Pr.08-46~48). Using terminal 44 function after setting contact status of 45 and 46 as shown in the following table.																																																																																																																																									
45	Reset initial reel diameter 1																																																																																																																																										
46	Reset initial reel diameter 2																																																																																																																																										
46		<table border="1"> <thead> <tr> <th>MI=46</th> <th>MI=45</th> <th>MI=44</th> </tr> </thead> <tbody> <tr> <td>OFF</td> <td>OFF</td> <td>ON: writing Pr.08-46 setting into Pr.08-54</td> </tr> <tr> <td>OFF</td> <td>ON</td> <td>ON: writing Pr.08-47 setting into Pr.08-54</td> </tr> <tr> <td>ON</td> <td>OFF</td> <td>ON: writing Pr.08-48 setting into Pr.08-54</td> </tr> <tr> <td>ON</td> <td>ON</td> <td>ON: reset Pr.08-54 setting to the factory setting</td> </tr> </tbody> </table>	MI=46	MI=45	MI=44	OFF	OFF	ON: writing Pr.08-46 setting into Pr.08-54	OFF	ON	ON: writing Pr.08-47 setting into Pr.08-54	ON	OFF	ON: writing Pr.08-48 setting into Pr.08-54	ON	ON	ON: reset Pr.08-54 setting to the factory setting																																																																																																																										
MI=46	MI=45	MI=44																																																																																																																																									
OFF	OFF	ON: writing Pr.08-46 setting into Pr.08-54																																																																																																																																									
OFF	ON	ON: writing Pr.08-47 setting into Pr.08-54																																																																																																																																									
ON	OFF	ON: writing Pr.08-48 setting into Pr.08-54																																																																																																																																									
ON	ON	ON: reset Pr.08-54 setting to the factory setting																																																																																																																																									
47	Reset PID control integration of tension	When this contact is ON, the PID control integration of tension is reset.																																																																																																																																									

Settings	Functions	Descriptions
48	Mechanical Gear Ratio Switch	When this contact is ON, the mechanical gear ratio switch will be the second group A2/B2 (refer to Pr.10-29 and Pr.10-30).
49	Enable Drive	<p>When this contact is ON, the output of drive will stop.</p>
50	Reserved	

02-07 ✓ UP/DOWN Key Mode

Control mode	VF	VFPG	SVC	FOCPG	Factory setting: 0
Settings		0	Up/down by the accel/decel time		
		1	Up/down constant speed (Pr.02-08)		

02-08 ✓ The Acceleration/Deceleration Speed of the UP/DOWN Key with Constant Speed Unit: 0.01

Control mode	VF	VFPG	SVC	FOCPG	Factory setting: 0.01
Settings		0.01 ~ 1.00Hz/ms			

These settings are used when multi-function input terminals are set to 19/20.

02-09	Digital Input Response Time					Unit: 0.001
Control mode	VF	VFPG	SVC	FOCPG	TQCPG	Factory setting: 0.005
Settings	0.001~ 30.000 sec					

This parameter is used for digital input terminal signal delay and confirmation. The delay time is confirmation time to prevent some uncertain interferences that would result in error (except for the counter input) in the input of the digital terminals (FWD, REV and MI1-6). Under this condition, confirmation for this parameter could be improved effectively, but the response time will be somewhat delayed.

02-10	Digital Input Operation Direction					Unit: 1
Control mode	VF	VFPG	SVC	FOCPG	TQCPG	Factory setting: 0
Settings	0 ~ 65535					

The setting of this parameter is decimal value.

This parameter is used to set the input signal level and it won't be affected by the SINK/SOURCE status.

Bit0 is for FWD terminal, bit1 is for REV terminal and bit2 to bit15 is for MI1 to MI14.

User can change terminal status by communicating.

For example, MI1 is set to 1 (multi-step speed command 1), MI2 is set to 2 (multi-step speed command 2). Then the forward + 2nd step speed command=1001(binary)=9 (Decimal). Only need to set Pr.02-10=9 by communication and it can forward with 2nd step speed. It doesn't need to wire any multi-function terminal.

bit15	bit14	bit13	bit12	bit11	bit10	bit9	bit8	bit7	bit6	bit5	bit4	bit3	bit2	bit1	bit0
MI14	MI13	MI12	MI11	MI10	MI9	MI8	MI7	MI6	MI5	MI4	MI3	MI2	MI1	REV	FWD

02-11	Multi-function Output 1 RA, RB, RC (Relay1)					Factory Setting: 11
--------------	---	--	--	--	--	---------------------

02-12	Multi-function Output 2 MRA, MRC (Relay2)					Factory Setting: 1
--------------	---	--	--	--	--	--------------------

02-13	Multi-function Output 3 (MO1)					Factory Setting: 0
--------------	-------------------------------	--	--	--	--	--------------------

02-14	Multi-function Output 4 (MO2)	Factory Setting: 0
02-35	Multi-function Output 5 (MO3) (need to use with EMV-APP01)	Factory Setting: 0
02-36	Multi-function Output 5 6 (MO4) (need to use with EMV-APP01)	Factory Setting: 0
02-37	Multi-function Output 5 7 (MO3MO5) (need to use with EMV-APP01)	Factory Setting: 0
02-38	Multi-function Output 8 (MO6) (need to use with EMV-APP01)	Factory Setting: 0
02-39	Multi-function Output 9 (MO7) (need to use with EMV-APP01)	Factory Setting: 0
02-40	Multi-function Output 10 (MO8) (need to use with EMV-APP01)	Factory Setting: 0
02-41	Multi-function Output 11 (MO9) (need to use with EMV-APP01)	Factory Setting: 0
02-42	Multi-function Output 12 (MOA) (need to use with EMV-APP01)	Factory Setting: 0
Settings 0-50		

Summary of function settings (Take the normally open contact for example, ON: contact is closed, OFF: contact is open)

Settings	Control Mode				
	VF	VFPG	SVC	FOCPG	TQCPG
0: No function					
1: Operation indication	○	○	○	○	○
2: Operation speed attained	○	○	○	○	○
3: Desired frequency attained 1 (Pr.02-19)	○	○	○	○	○
4: Desired frequency attained 2 (Pr.02-21)	○	○	○	○	○
5: Zero speed (frequency command)	○	○	○	○	○
6: Zero speed with stop (frequency command)	○	○	○	○	○
7: Over torque (OT1) (Pr.06-06~06-08)	○	○	○	○	○
8: Over torque (OT2) (Pr.06-09~06-11)	○	○	○	○	○
9: Drive ready	○	○	○	○	○
10: User-defined Low-voltage Detection	○	○	○	○	○
11: Malfunction indication	○	○	○	○	○
12: Mechanical brake release (Pr.02-31)	○	○	○	○	○
13: Overheat	○	○	○	○	○
14: Software brake signal indication	○	○	○	○	○
15: PID feedback error	○	○	○	○	○
16: Slip error (oSL)	○	○	○	○	○
17: Terminal count value attained (Pr.02-16)	○	○	○	○	○
18: Preliminary count value attained (Pr.02-17)	○	○	○	○	○
19: Baseblock (B.B.) Indication	○	○	○	○	○

Settings	Control Mode				
	VF	VFPG	SVC	FOCPG	TQCPG
20: Warning output	<input type="checkbox"/>	<input type="checkbox"/>	<input type="checkbox"/>	<input type="checkbox"/>	<input type="checkbox"/>
21: Over voltage warning	<input type="checkbox"/>	<input type="checkbox"/>	<input type="checkbox"/>	<input type="checkbox"/>	<input type="checkbox"/>
22: Over-current stall prevention warning	<input type="checkbox"/>	<input type="checkbox"/>	<input type="checkbox"/>	<input type="checkbox"/>	<input type="checkbox"/>
23: Over-voltage stall prevention warning	<input type="checkbox"/>	<input type="checkbox"/>	<input type="checkbox"/>	<input type="checkbox"/>	<input type="checkbox"/>
24: Operation mode indication	<input type="checkbox"/>	<input type="checkbox"/>	<input type="checkbox"/>	<input type="checkbox"/>	<input type="checkbox"/>
25: Forward command	<input type="checkbox"/>	<input type="checkbox"/>	<input type="checkbox"/>	<input type="checkbox"/>	<input type="checkbox"/>
26: Reverse command	<input type="checkbox"/>	<input type="checkbox"/>	<input type="checkbox"/>	<input type="checkbox"/>	<input type="checkbox"/>
27: Output when current \geq Pr.02-32	<input type="checkbox"/>	<input type="checkbox"/>	<input type="checkbox"/>	<input type="checkbox"/>	<input type="checkbox"/>
28: Output when current $<$ Pr.02-32	<input type="checkbox"/>	<input type="checkbox"/>	<input type="checkbox"/>	<input type="checkbox"/>	<input type="checkbox"/>
29: Output when frequency \geq Pr.02-33	<input type="checkbox"/>	<input type="checkbox"/>	<input type="checkbox"/>	<input type="checkbox"/>	<input type="checkbox"/>
30: Output when frequency $<$ Pr.02-33	<input type="checkbox"/>	<input type="checkbox"/>	<input type="checkbox"/>	<input type="checkbox"/>	<input type="checkbox"/>
31: Y-connection for the motor coil	<input type="checkbox"/>	<input type="checkbox"/>	<input type="checkbox"/>	<input type="checkbox"/>	<input type="checkbox"/>
32: Δ connection for the motor coil	<input type="checkbox"/>	<input type="checkbox"/>	<input type="checkbox"/>	<input type="checkbox"/>	<input type="checkbox"/>
33: Zero speed (actual output frequency)	<input type="checkbox"/>	<input type="checkbox"/>	<input type="checkbox"/>	<input type="checkbox"/>	<input type="checkbox"/>
34: Zero speed with Stop (actual output frequency)	<input type="checkbox"/>	<input type="checkbox"/>	<input type="checkbox"/>	<input type="checkbox"/>	<input type="checkbox"/>
35: Error output selection 1 (Pr.06-23)	<input type="checkbox"/>	<input type="checkbox"/>	<input type="checkbox"/>	<input type="checkbox"/>	<input type="checkbox"/>
36: Error output selection 2 (Pr.06-24)	<input type="checkbox"/>	<input type="checkbox"/>	<input type="checkbox"/>	<input type="checkbox"/>	<input type="checkbox"/>
37: Error output selection 3 (Pr.06-25)	<input type="checkbox"/>	<input type="checkbox"/>	<input type="checkbox"/>	<input type="checkbox"/>	<input type="checkbox"/>
38: Error output selection 4 (Pr.06-26)	<input type="checkbox"/>	<input type="checkbox"/>	<input type="checkbox"/>	<input type="checkbox"/>	<input type="checkbox"/>
39: Position attained (Pr.10-19)	<input type="checkbox"/>	<input type="checkbox"/>	<input type="checkbox"/>	<input type="checkbox"/>	<input type="checkbox"/>
40: Speed attained (including zero speed)	<input type="checkbox"/>	<input type="checkbox"/>	<input type="checkbox"/>	<input type="checkbox"/>	<input type="checkbox"/>
41: Multi-position attained	<input type="checkbox"/>	<input type="checkbox"/>	<input type="checkbox"/>	<input type="checkbox"/>	<input type="checkbox"/>
42: Crane function	<input type="checkbox"/>	<input type="checkbox"/>	<input type="checkbox"/>	<input type="checkbox"/>	<input type="checkbox"/>
43: Motor zero-speed output (Pr.02-43)	<input type="checkbox"/>	<input type="checkbox"/>	<input type="checkbox"/>	<input type="checkbox"/>	<input type="checkbox"/>
44: Max. reel diameter attained	<input type="checkbox"/>	<input type="checkbox"/>	<input type="checkbox"/>	<input type="checkbox"/>	<input type="checkbox"/>
45: Empty reel diameter attained	<input type="checkbox"/>	<input type="checkbox"/>	<input type="checkbox"/>	<input type="checkbox"/>	<input type="checkbox"/>
46: Broken belt detection	<input type="checkbox"/>	<input type="checkbox"/>	<input type="checkbox"/>	<input type="checkbox"/>	<input type="checkbox"/>
47: Break release at stop	<input type="checkbox"/>	<input type="checkbox"/>	<input type="checkbox"/>	<input type="checkbox"/>	<input type="checkbox"/>
48: Error PID feedback of tension	<input type="checkbox"/>	<input type="checkbox"/>	<input type="checkbox"/>	<input type="checkbox"/>	<input type="checkbox"/>
49: Reserved					
50: Reserved					

Settings	Functions	Descriptions
0	No Function	
1	Operation Indication	Active when the drive is not at STOP.
2	Master Frequency Attained	Active when the AC motor drive reaches the output frequency setting.
3	Desired Frequency Attained 1 (Pr.02-19)	Active when the desired frequency (Pr.02-19) is attained.
4	Desired Frequency Attained 2 (Pr.02-21)	Active when the desired frequency (Pr.02-21) is attained.
5	Zero Speed (frequency command)	Active when frequency command =0. (the drive should be at RUN mode)
6	Zero Speed with Stop (frequency command)	Active when frequency command =0 or stop.

Settings	Functions	Descriptions
7	Over Torque (OT1) (Pr.06-06-06-08)	Active when detecting over-torque. Refer to Pr.06-06 (over-torque detection selection-OT1), Pr.06-07 (over-torque detection level-OT1) and Pr.06-08 (over-torque detection time-OT1).
8	Over Torque (OT2) (Pr.06-09-06-11)	Active when detecting over-torque. Refer to Pr.06-09 (over-torque detection selection-OT2), Pr.06-10 (over-torque detection level-OT2) and Pr.06-11 (over-torque detection time-OT2).
9	Drive Ready	Active when the drive is ON and no abnormality detected.
10	User-defined Low-voltage Detection	Active when the DC Bus voltage is too low. (refer to Pr.06-00 low voltage level)
11	Malfunction Indication	Active when fault occurs (except Lv stop).
12	Mechanical Brake Release (Pr.02-31)	When drive runs after Pr.02-31, it will be ON. This function should be used with DC brake and it is recommended to use contact "b"(N.C).
13	Overheat	Active when IGBT or heat sink overheats to prevent OH turn off the drive. (refer to Pr.06-05)
14	Software Brake Signal Indication	This function is used in conjunction with a VFDB Brake Unit. The output will be activated when the drive needs help braking the load. A smooth deceleration is achieved by using this function. (refer to Pr.07-00)
15	PID Feedback Error	Active when the feedback signal is abnormal.
16	Slip Error (oSL)	Active when the slip error is detected.
17	Terminal Count Value Attained	Active when the counter reaches Terminal Counter Value (Pr.02-16).
18	Preliminary Counter Value Attained	Active when the counter reaches Preliminary Counter Value (Pr.02-17).
19	Baseblock (B.B.) Indication	Active when the output of the AC motor drive is shut off during baseblock.
20	Warning Output	Active when the warning is detected.
21	Over-voltage Warning	Active when the over-voltage is detected.
22	Over-current Stall Prevention Warning	Active when the over-current stall prevention is detected.
23	Over-voltage Stall prevention Warning	Active when the over-voltage stall prevention is detected.

Settings	Functions	Descriptions
24	Operation Mode Indication	Active when the operation command is controlled by external terminal.
25	Forward Command	Active when the operation direction is forward.
26	Reverse Command	Active when the operation direction is reverse.
27	Output when Current \geq Pr.02-32	Active when current is \geq Pr.02-32.
28	Output when Current $<$ Pr.02-32	Active when current is $<$ Pr.02-32.
29	Output when frequency \geq Pr.02-33	Active when frequency is \geq Pr.02-33.
30	Output when Frequency $<$ Pr.02-33	Active when frequency is $<$ Pr.02-33.
31	Y-connection for the Motor Coil	Active when PR.05-12 is less than PR.05-11 and time is more than Pr.05-30.
32	Δ -connection for the Motor Coil	Active when PR.05-12 is higher than PR.05-11 and time is more than Pr.05-30.
33	Zero Speed (actual output frequency)	Active when the actual output frequency is 0. (the drive should be at RUN mode)
34	Zero Speed with Stop (actual output frequency)	Active when the actual output frequency is 0 or Stop.
35	Error Output Selection 1 (Pr.06-23)	Active when Pr.06-23 is ON.
36	Error Output Selection 2 (Pr.06-24)	Active when Pr.06-24 is ON.
37	Error Output Selection 3 (Pr.06-25)	Active when Pr.06-25 is ON.
38	Error Output Selection 4 (Pr.06-26)	Active when Pr.06-26 is ON.
39	Position Attained (Pr.10-19)	Active when the PG position control point reaches Pr.10-19.
40	Speed Attained (including zero speed)	Active when the output frequency reaches frequency setting or stop.

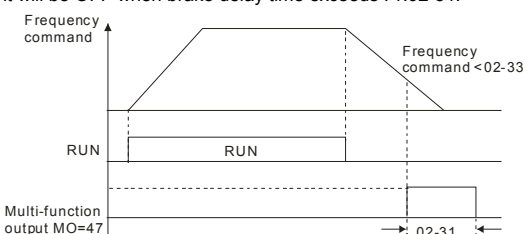
Settings	Functions	Descriptions
41	Multi-position Attained	User can set any three multi-function input terminals to 41. The current position action status of these three terminals will be outputted. Example: if setting Pr.02-11, Pr.02-12 and Pr.02-13 to 41 and only the multi-position of the second point has been done. Therefore, current status are RA (OFF), MRA (ON) and MO1 (OFF). In this way, their status is 010.
42	Crane Function	This function should be used with Pr.02-31, Pr.02-32 and Pr.02-33. Active when setting Pr.07-16=Pr.02-33 and Fcmd > Pr.02-33 and output current > Pr.02-32 and Time > Pr.02-31. The example of the crane application is in the following for your reference.
43	Motor Zero-speed Output (Pr.02-43)	Active when motor actual speed is less than Pr.02-43.
44	Max. Reel Diameter Attained	Active when the reel diameter is equal to Pr.08-43 in the tension control mode.
45	Empty Reel Diameter Attained	Active when the reel diameter is equal to Pr.08-44 in the tension control mode.
46	Broken Belt Detection	In the tension control mode, the broken belt occurs when 1. line speed is higher than Pr.08-61, 2. the error of reel diameter exceeds Pr.08-61, 3. detection time exceeds Pr.08-62
47	Break Release at Stop	When drive stops, the corresponding multi-function terminal will be ON if the frequency is less than Pr.02-33. After it is ON, it will be OFF when brake delay time exceeds Pr.02-31. 
48	Error PID Feedback of Tension	In the tension control mode, when the error between PID target value and PID feedback exceeds Pr.08-63 and allowance error detection time of tension PID feedback exceeds Pr.08-64, please refer to Pr. 08-64 for error treatment of tension PID feedback.
49	Reserved	
50	Reserved	

Example of crane function

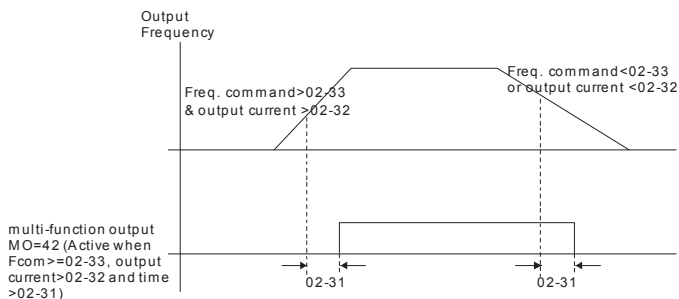

It is recommended to be used with Dwell function (Pr.07-15 to Pr.07-18) as shown in the following:

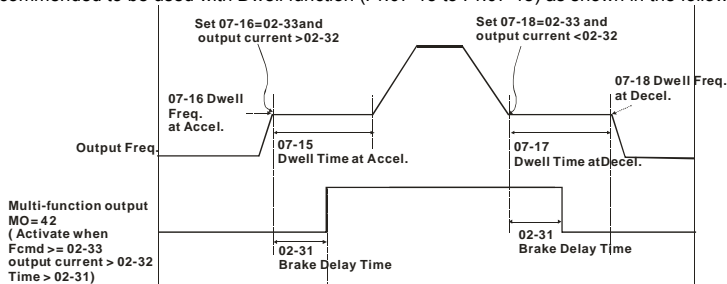
02-15 Multi-direction

Unit: 1

Control mode	VF	VFPG	SVC	FOCPG	TQCPG
--------------	----	------	-----	-------	-------

Factory setting: 0

Settings 0 ~ 65535

The setting of this parameter is decimal value.

This parameter is set via bit setting. If a bit is 1, the corresponding output acts in the opposite way.

Example:

If Pr02-11=1 and Pr02-15=0, Relay 1 RA-RC is closed when the drive runs and is open when the drive is stopped.

If Pr02-11=1 and Pr02-15=1, Relay 1 RA-RC is open when the drive runs and is closed when the drive is stopped.

**Bit setting**

bit3 MO2	bit2 MO1	bit1 RA	bit0 MRA	Pr02-15
0	0	0	0	0
0	0	0	1	1
0	0	1	0	2
0	0	1	1	3
0	1	0	0	4
0	1	0	1	5
0	1	1	0	6
0	1	1	1	7
1	0	0	0	8
1	0	0	1	9
1	0	1	0	10
1	0	1	1	11
1	1	0	0	12
1	1	0	1	13
1	1	1	0	14
1	1	1	1	15

02-16 / Terminal Count Value

Unit:1

Control mode	VF	VFPG	SVC	FOCPG	TQCPG

Factory setting: 0

Settings 0 ~ 65535



The counter trigger can be set by the multi-function terminal MI6 (set Pr.02-06 to 23).

Upon completion of counting, the specified output terminal will be activated (Pr.02-11 to Pr.02-14 is set to 17).



When the display shows c5555, the drive has counted 5,555 times. If display shows c5555*, it means that real counter value is between 55,550 to 55,559.

02-17 / Preliminary Count Value

Unit:1

Control mode	VF	VFPG	SVC	FOCPG	TQCPG

Factory setting: 0

Settings 0 ~ 65535



When the counter value reaches this value, the corresponding multi-function output terminal will be activated, provided one of Pr. 02-11 to 02-14 set to 18 (Preliminary Count Value Setting). This parameter can be used for the end of the counting to make the drive runs from the low speed to stop.

Chapter 4 Parameters | VFD-VE

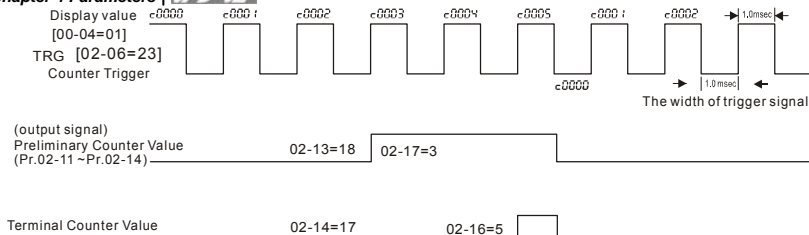

02-18 Digital Output Gain

Unit: 1

Control mode	VF	VFPG	SVC	FOCPG	TQCPG	Factory setting: 1
Settings			1 ~ 40			

It is used to set the signal for the digital output terminals (DFM-DCM) and digital frequency output (pulse X work period=50%). Output pulse per second = output frequency X Pr.02-18.

02-19 Desired Frequency Attained 1

Unit: 0.01

Control mode	VF	VFPG	SVC	FOCPG	Factory setting: 60.00/50.00
--------------	----	------	-----	-------	------------------------------

02-20 The Width of the Desired Frequency Attained 1

Unit: 0.01

Control mode	VF	VFPG	SVC	FOCPG	Factory setting: 2.00
--------------	----	------	-----	-------	-----------------------

02-21 Desired Frequency Attained 2

Unit: 0.01

Control mode	VF	VFPG	SVC	FOCPG	Factory setting: 60.00/50.00
--------------	----	------	-----	-------	------------------------------

02-22 The Width of the Desired Frequency Attained 2

Unit: 0.01

Control mode	VF	VFPG	SVC	FOCPG	Factory setting: 2.00
--------------	----	------	-----	-------	-----------------------

Settings 0.00 ~ 600.00Hz

Once output frequency reaches desired frequency and the corresponding multi-function output terminal is set to 3 or 4 (Pr.02-11~Pr.02-14), this multi-function output terminal will be ON.

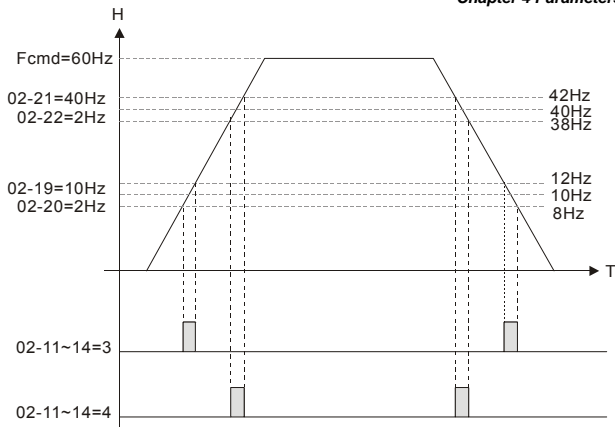
**02-31** Brake Delay Time

Unit:0.001

Control mode

VF

VFP

SVC

FOCPG

TQCPG

Factory setting: 0.000

Settings 0.000~65.000 Sec

When the AC motor drive runs after Pr.02-31 delay time, the corresponding multi-function output terminal (12: mechanical brake release) will be ON. It is recommended to use this function with DC brake.

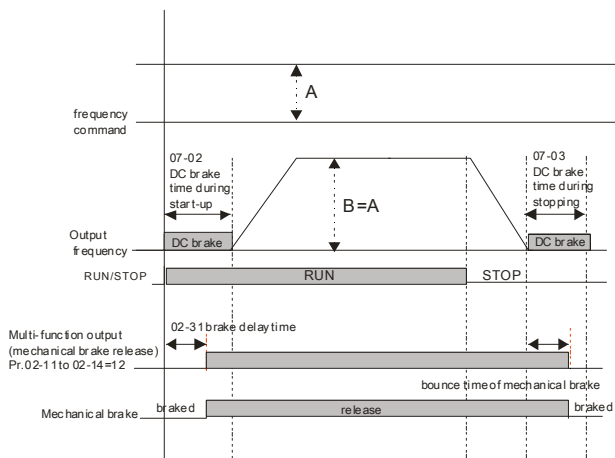

-  If this parameter is used without DC brake, it will be invalid. Refer to the following operation timing.

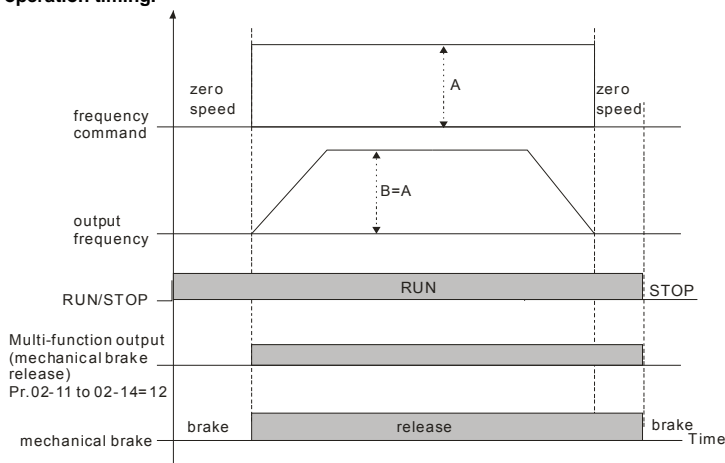



02-32 Output Current Level Setting for External Terminals

Unit:1

Control mode	VF	VFP	SVC	FOCP	TQCP
Settings			0~100%		

Factory setting: 0



-  When output current is higher or equal to Pr.02-32, it will activate multi-function output terminal (Pr.02-11 to Pr.02-14 is set to 27).
-  When output current is lower than Pr.02-32, it will activate multi-function output terminal (Pr.02-11 to Pr.02-14 is set to 28).

02-33 Output Boundary for External Terminals

Unit:0.01

Control mode	VF	VFP	SVC	FOCP	TQCP
Settings			0.00~+60.00Hz		

Factory setting: 0.00

-  When output frequency is higher than Pr.02-33, it will activate the multi-function terminal (Pr.02-11 to Pr.02-14 is set to 29).
-  When output frequency is lower than Pr.02-33, it will activate the multi-function terminal (Pr.02-11 to Pr.02-14 is set to 30).

02-34 External Operation Control Selection after Reset

Unit: 1



Control mode	VF	VFP	SVC	FOCPG	TQCPG	Factory setting:
Settings			0: Disable			0
			1: Drive runs if run command exists after reset			

-  **After clearing fault once a fault is detected and the external terminal for RUN keeps ON, the drive can run after pressing RESET key.**

02-43 Zero-speed Level of Motor

Unit: 1

Control mode	VFP	FOCPG	TQCPG	Factory setting:
Settings		0~65535rpm		0

-  **This parameter should be used with the multi-function output terminals (set to 43).**
-  **This parameter is used to set the level of motor zero-speed. When the actual speed is lower than this setting, the corresponding multi-function output terminal 43 will be ON as shown as follows.**

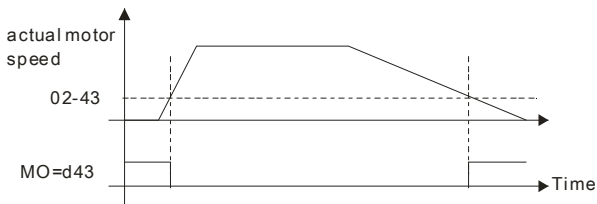

Group 3 Analog Input/Output Parameters

03-00  Analog Input 1 (AVI)

Factory Setting: 1



03-01  Analog Input 2 (ACI)

Factory Setting: 0

03-02  Analog Input 3 (AUI)

Factory Setting: 0

Settings	Control Mode				
	VF	VFPG	SVC	FOCPG	TQCPG
0: No function	<input type="radio"/>	<input type="radio"/>	<input type="radio"/>	<input type="radio"/>	<input type="radio"/>
1: Frequency command (torque limit under TQR control mode)	<input type="radio"/>	<input type="radio"/>	<input type="radio"/>	<input type="radio"/>	<input type="radio"/>
2: torque command (torque limit under speed mode)					<input type="radio"/>
3: Torque compensation command	<input type="radio"/>	<input type="radio"/>	<input type="radio"/>	<input type="radio"/>	<input type="radio"/>
4: PID target value (refer to group 8)	<input type="radio"/>	<input type="radio"/>	<input type="radio"/>	<input type="radio"/>	
5: PID feedback signal (refer to group 8)	<input type="radio"/>	<input type="radio"/>	<input type="radio"/>	<input type="radio"/>	
6: P.T.C. thermistor input value	<input type="radio"/>	<input type="radio"/>	<input type="radio"/>	<input type="radio"/>	<input type="radio"/>
7: Positive torque limit				<input type="radio"/>	
8: Negative torque limit				<input type="radio"/>	
9: Regenerative torque limit				<input type="radio"/>	
10: Positive/negative torque limit				<input type="radio"/>	
11: PID feedback signal of tension	<input type="radio"/>	<input type="radio"/>	<input type="radio"/>	<input type="radio"/>	<input type="radio"/>
12: Line speed	<input type="radio"/>	<input type="radio"/>	<input type="radio"/>	<input type="radio"/>	<input type="radio"/>
13: Reel diameter	<input type="radio"/>	<input type="radio"/>	<input type="radio"/>	<input type="radio"/>	<input type="radio"/>
14: PID target value of tension (tension closed-loop)	<input type="radio"/>	<input type="radio"/>	<input type="radio"/>	<input type="radio"/>	<input type="radio"/>
15: Tension setting (tension open-loop)					<input type="radio"/>
16: Zero-speed tension					<input type="radio"/>
17: Tension taper					<input type="radio"/>

-  When it is frequency command or TQC speed limit, the corresponding value for 0-±10V/4-20mA is 0 – max. output frequency(Pr.01-00)
-  When it is torque command or torque limit, the corresponding value for 0-±10V/4-20mA is 0 – max. output torque (Pr.07-22).
-  When it is torque compensation, the corresponding value for 0-±10V/4-20mA is 0 – rated torque.

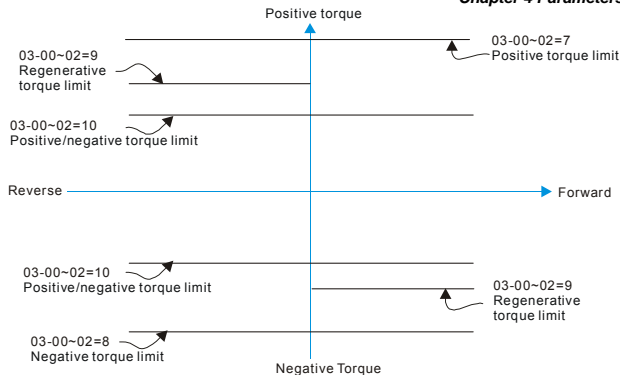

03-03	↗ Analog Input Bias 1 (AVI)					Unit: 0.1
Control mode	VF	VFPG	SVC	FOCPG	TQCPG	Factory setting: 0
Settings	-100.0~100.0%					

It is used to set the corresponding AVI voltage of the external analog input 0.

03-04	↗ Analog Input Bias 1 (ACI)					Unit: 0.1
Control mode	VF	VFPG	SVC	FOCPG	TQCPG	Factory setting: 0
Settings	-100.0~100.0%					

It is used to set the corresponding ACI voltage of the external analog input 0.

03-05	↗ Analog Input Bias 1 (AUI)					Unit: 0.1
Control mode	VF	VFPG	SVC	FOCPG	TQCPG	Factory setting: 0
Settings	-100.0~100.0%					

It is used to set the corresponding AUI voltage of the external analog input 0.

03-06	↗ Positive/negative Bias Mode (AVI)					
03-07	↗ Positive/negative Bias Mode (ACI)					
03-08	↗ Positive/negative Bias Mode (AUI)					
Control mode	VF	VFPG	SVC	FOCPG	TQCPG	Factory setting: 0
Settings	0	Zero bias				
	1	Lower than bias=bias				
	2	Greater than bias=bias				

- 3 The absolute value of the bias voltage while serving as the center
- 4 Serve bias as the center

In a noisy environment, it is advantageous to use negative bias to provide a noise margin. It is recommended NOT to use less than 1V to set the operation frequency.

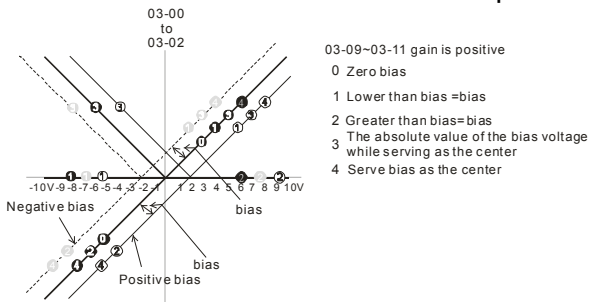

03-09 Analog Input Gain 1 (AVI) Unit: 1

03-10 Analog Input Gain 1 (ACI) Unit: 1

03-11 Analog Input Gain 1 (AUI) Unit: 1

Control mode VF VFPG SVC FOCPCG TQCPG Factory setting: 100.0

Settings -500.0~500.0%

Parameters 03-03 to 03-11 are used when the source of frequency command is the analog voltage/current signal.

03-12 ACI/AVI2 Selection

Control mode VF VFPG SVC FOCPCG TQCPG Factory setting: 0

Settings 0 ACI
1 AVI 2

There are two AVI analog inputs can be used when this parameter is set to 1 and the SW2 on the control board is set to AVI2. At this moment, ACI is for voltage input.

03-13 Analog Input Delay Time (AVI) Unit: 0.01

03-14 Analog Input Delay Time (ACI) Unit: 0.01

03-15 Analog Input Delay Time (AUI) Unit: 0.01

Control mode VF VFPG SVC FOCPCG TQCPG Factory setting: 0.01

Settings 0.00 to 2.00 sec

 These input delays can be used to filter noisy analog signal.

03-16	✎ Addition Function of the Analog Input					Factory setting: 0
Control mode	VF	VFGP	SVC	FOCPG	TQCPG	
Settings		0	Disable (AVI, ACI, AUI)			
		1	Enable			

 When Pr.03-16 is set to 0 and the analog input setting is the same, the priority for AVI, ACI and AUI are AVI>ACI>AUI.

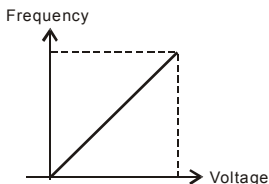

$$F_{\text{command}} = [(a y + \text{bias}) * \text{gain}] * \frac{F_{\text{max}}(01-00)}{10\text{V or }16\text{mA}}$$

F_{command} : the corresponding frequency for 10V or 20mA

$a y$: 10 or 16mA

bias : Pr.03-03, Pr.03-04, Pr.03-05

gain : Pr.03-09, Pr.03-10, Pr.03-11

03-17	✎ Loss of the ACI Signal					Factory setting: 0
Control mode	VF	VFGP	SVC	FOCPG	TQCPG	
Settings		0	Disable			
		1	Continue operation at the last frequency			
		2	Decelerate to stop			
		3	Stop immediately and display E.F.			

 This parameter determines the behavior when ACI is lost.

03-18	✎ Analog Output 1					Unit: 1
03-21	✎ Analog Output 2 (need to be used with EMV-APP01)					Unit: 1
03-24	✎ Analog Output 3 (need to be used with EMV-APP01)					Unit: 1
Control mode	VF	VFGP	SVC	FOCPG	TQCPG	Factory setting: 0
Settings		0 to 19				

Settings	Functions	Descriptions
0	Output frequency (Hz)	Max. frequency Pr.01-00 is regarded as 100%.

Settings	Functions	Descriptions
1	Frequency command (Hz)	Max. frequency Pr.01-00 is regarded as 100%.
2	Motor speed (Hz)	600Hz is regarded as 100%
3	Output current (rms)	(2.5 X rated current) is regarded as 100%
4	Output voltage	(2 X rated voltage) is regarded as 100%
5	DC Bus Voltage	450V (900V)=100%
6	Power factor	-1.000~1.000=100%
7	Power	Rated power is regarded as 100%
8	Output torque	Full-load torque is regarded as 100%
9	AVI	0~10V=0~100%
10	ACI	0~20mA=0~100%
11	AUI	-10~10V=0~100%
12	q-axis current	(2.5 X rated current) is regarded as 100%
13	q-axis feedback value	(2.5 X rated current) is regarded as 100%
14	d-axis current	(2.5 X rated current) is regarded as 100%
15	d-axis feedback value	(2.5 X rated current) is regarded as 100%
16	q-axis voltage	250V (500V) =100%
17	d-axis voltage	250V (500V) =100%
18	Torque command	Rated torque is regarded as 100%
19	Pulse frequency command	Max. frequency Pr.01-00 is regarded as 100%.

03-19	↗ Gain for Analog Output 1	Unit: 0.1
03-22	↗ Gain for Analog Output 2 (need to be used with EMV-APP01)	Unit: 0.1
03-25	↗ Gain for Analog Output 3 (need to be used with EMV-APP01)	Unit: 0.1
Control mode	VF VFG SVC FOCPG TQCPG	Factory setting: 100.0
	Settings 0 to 200.0%	

 **It is used to adjust the analog voltage level that terminal AFM outputs.**

 **This parameter is set the corresponding voltage of the analog output 0.**

03-20	↗ Analog Output 1 Value in REV Direction	
03-23	↗ Analog Output 2 Value in REV Direction	
03-26	↗ Analog Output 3 Value in REV Direction	
Control mode	VF VFG SVC FOCPG TQCPG	Factory setting: 0
Settings	0 Absolute value in REV direction	
	1 Output 0V in REV direction	
	2 Enable output voltage in REV direction	

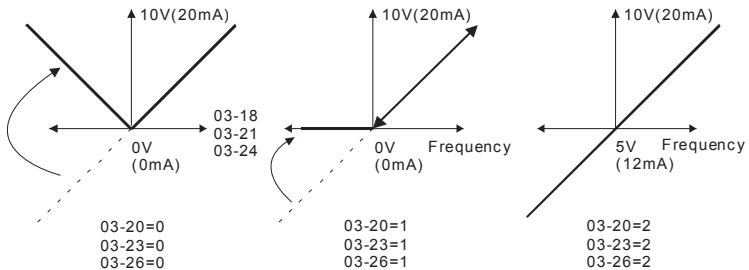

Selections for the analog output direction

Group 4 Multi-Step Speed Parameters

04-00	↗ 1st Step Speed Frequency	Unit: 0.01
04-01	↗ 2nd Step Speed Frequency	Unit: 0.01
04-02	↗ 3rd Step Speed Frequency	Unit: 0.01
04-03	↗ 4th Step Speed Frequency	Unit: 0.01
04-04	↗ 5th Step Speed Frequency	Unit: 0.01
04-05	↗ 6th Step Speed Frequency	Unit: 0.01
04-06	↗ 7th Step Speed Frequency	Unit: 0.01
04-07	↗ 8th Step Speed Frequency	Unit: 0.01
04-08	↗ 9th Step Speed Frequency	Unit: 0.01
04-09	↗ 10th Step Speed Frequency	Unit: 0.01
04-10	↗ 11th Step Speed Frequency	Unit: 0.01
04-11	↗ 12th Step Speed Frequency	Unit: 0.01
04-12	↗ 13th Step Speed Frequency	Unit: 0.01
04-13	↗ 14th Step Speed Frequency	Unit: 0.01
04-14	↗ 15th Step Speed Frequency	Unit: 0.01

Control mode	VF	VFPG	SVC	FOCPG	Factory setting: 0.00
	Settings	0.00 to 600.00 Hz			

04-15	↗ Multi-position 1	Unit: 1
04-16	↗ Multi-position 2	Unit: 1
04-17	↗ Multi-position 3	Unit: 1
04-18	↗ Multi-position 4	Unit: 1
04-19	↗ Multi-position 5	Unit: 1
04-20	↗ Multi-position 6	Unit: 1
04-21	↗ Multi-position 7	Unit: 1
04-22	↗ Multi-position 8	Unit: 1
04-23	↗ Multi-position 9	Unit: 1
04-24	↗ Multi-position 10	Unit: 1
04-25	↗ Multi-position 11	Unit: 1
04-26	↗ Multi-position 12	Unit: 1
04-27	↗ Multi-position 13	Unit: 1
04-28	↗ Multi-position 14	Unit: 1
04-29	↗ Multi-position 15	Unit: 1

Control mode VFPG FOCPG

Factory setting: 0

Settings 0 to 65535

 Please refer to the explanation of Pr.02-00 to Pr.02-06.

	MI4	MI3	MI2	MI1	
Pr.10-19 setting	0	0	0	0	Master frequency
04-15 multi-position 1	0	0	0	1	04-00 1 st step speed frequency
04-16 multi-position 2	0	0	1	0	04-01 2 nd step speed frequency
04-17 multi-position 3	0	0	1	1	04-02 3 rd step speed frequency
04-18 multi-position 4	0	1	0	0	04-03 4 th step speed frequency
04-19 multi-position 5	0	1	0	1	04-04 5 th step speed frequency
04-20 multi-position 6	0	1	1	0	04-05 6 th step speed frequency
04-21 multi-position 7	0	1	1	1	04-06 7 th step speed frequency
04-22 multi-position 8	1	0	0	0	04-07 8 th step speed frequency
04-23 multi-position 9	1	0	0	1	04-08 9 th step speed frequency
04-24 multi-position 10	1	0	1	0	04-09 10 th step speed frequency
04-25 multi-position 11	1	0	1	1	04-10 11 th step speed frequency
04-26 multi-position 12	1	1	0	0	04-11 12 th step speed frequency
04-27 multi-position 13	1	1	0	1	04-12 13 th step speed frequency
04-28 multi-position 14	1	1	1	0	04-13 14 th step speed frequency
04-29 multi-position 15	1	1	1	1	04-14 15 th step speed frequency

Group 5 Motor Parameters**05-00** Motor Auto Tuning

Control mode	SVC	Factory setting:
Settings	0	No function
	1	Rolling test
	2	Static Test
	3	Reserved

Starting auto tuning by pressing RUN key and it will write the measure value into Pr.05-05 to Pr.05-09 for motor 1 and Pr.05-17 to Pr.05-21 for motor 2.

The steps to AUTO-Tuning are: (when setting to 1)

1. Make sure that all the parameters are set to factory settings and the motor wiring is correct.
2. Make sure the motor has no-load before executing auto-tuning and the shaft is not connected to any belt or gear motor. It is recommended to set to 2 or 3 if the motor can't separate from the load.
3. Motor 1: fill in Pr.01-02, Pr.01-01, Pr.05-01, Pr.05-02, Pr.05-03 and Pr.05-04 with correct values. Refer to motor capacity to set accel./decel. time.
Motor 2: fill in Pr.01-36, Pr.01-35, Pr.05-13, Pr.05-14, Pr.05-15 and Pr.05-16 with correct values. Refer to motor capacity to set accel./decel. time.
4. When Pr.05-00 is set to 1, the AC motor drive will execute auto-tuning immediately after receiving a "RUN" command. (NOTE: the motor will run!)
5. After executing, please check if there are values filled in Pr.05-05 to Pr.05-09 for motor 1 and Pr.05-17 to Pr.05-21 for motor 2.
6. Mechanical equivalent circuit

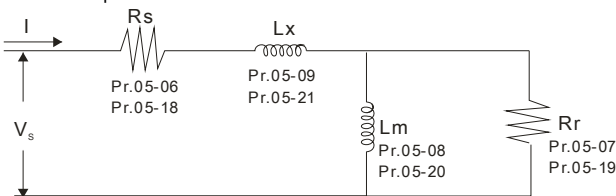

Mechanical equivalent circuit for VE series

If Pr.05-00 is set to 2, it needs to input Pr.05-05 for motor 1/Pr.05-17 for motor 2.

**NOTE**

1. In torque/vector control mode, it is not recommended to have motors run in parallel.
2. It is not recommended to use torque/vector control mode if motor rated power exceeds the rated power of the AC motor drive.
3. When auto-tuning 2 motors, it needs to set multi-function input terminals or change Pr.05-10 for motor 1/motor 2 selection.
4. The no-load current is usually 20~50% X rated current.
5. The rated speed can't be larger or equal to 120f/p (f: rated frequency 01-01/01-35; P: number of motor poles 05-04/05-16).

05-01	Full-load Current of Motor 1					Unit: Amp
Control mode	VF	VFP	SVC	FOCPG	TQCPG	Factory setting: #.##
	Settings					40 to 120% of drive's rated current

 **This value should be set according to the rated frequency of the motor as indicated on the motor nameplate. The factory setting is 90% X rated current.**

Example: The rated current for 7.5HP (5.5kW) is 25 and factory setting is 22.5A. The range for setting will be 10~30A.(25*40%=10 and 25*120%=30)

05-02	Rated Power of Motor 1 (kW)			Unit: 0.01
Control mode	SVC	FOCPG	TQCPG	Factory setting: #.##
	Settings			0 to 655.35 kW

 **It is used to set rated power of the motor 1. The factory setting is the power of the drive.**

05-03	Rated Speed of Motor 1 (rpm)				Unit: 1
Control mode	VFP	SVC	FOCPG	TQCPG	Factory setting: 1710 (60Hz, 4 poles) 1410 (50Hz, 4 poles)
	Settings				0 to 65535

 **It is used to set the rated speed of the motor and need to set according to the value indicated on the motor nameplate.**

05-04	Number of Motor Poles 1					Unit: 1
Control mode	VF	VFP	SVC	FOCPG	TQCPG	Factory setting: 4
	Settings					2 to 20

 **It is used to set the number of motor poles (must be an even number).**

05-05	No-load Current of Motor 1 (A)				Unit: Amp
Control mode	VFPG	SVC	FOCPG	TQCPG	Factory setting: ###
Settings	0 to factory setting of Pr.05-01				

 **The factory setting is 40% X rated current.**

05-06	Stator Resistance(Rs) of Motor 1				Unit: 0.001
05-07	Rotor Resistance(Rr) of Motor 1				Unit: 0.001
Control mode	SVC	FOCPG	TQCPG		Factory setting: ####
Settings	0~65.535Ω				

05-08	Magnetizing Inductance(Lm) of Motor 1				Unit: 0.1
05-09	Stator inductance(Lx) of Motor 1				Unit: 0.1
Control mode	SVC	FOCPG	TQCPG		Factory setting: ##
Settings	0~6553.5mH				

05-10	Motor 1/Motor 2 Selection					
Control mode	VF	VFPG	SVC	FOCPG	TQCPG	Factory setting: 1
Settings	1		Motor 1			
	2		Motor 2			

 **It is used to set the motor that driven by the AC motor drive.**

05-11	↗ Frequency for Y-connection/ Δ-connection Switch				Unit: 0.01	
Control mode	VF	VFPG	SVC	FOCPG	TQCPG	Factory setting: 60.00
Settings	0.00 to 600.00Hz					

05-12	Y-connection /Δ-connection Switch					
Control mode	VF	VFPG	SVC	FOCPG	TQCPG	Factory setting: 0
Settings	0		Disable			
	1		Enable			

05-30	↗ Delay Time for Y-connection/Δ-connection				Unit: 0.001	
Control mode	VF	VFPG	SVC	FOCPG		Factory setting: 0.200
Settings	0 to 60.000					

 **Pr.05-12 is used to enable/disable Y-connection/ Δ-connection Switch.**

- When Pr.05-12 is set to 1, the drive will select by Pr.05-11 setting and current motor frequency to switch motor to Y-connection or Δ -connection. AT the same time, it will also affect motor parameters (Pr.05-01 to 05-10/Pr.05-13 to Pr.05-21).**
- Pr.05-30 is used to set the switch delay time of Y-connection/ Δ -connection.**
- When output frequency reaches Y-connection/ Δ -connection switch frequency, drive will delay by Pr.05-30 before multi-function output terminals are active.**

Y- Δ connection switch: can be used for wide range motor
 Y connection for low speed: higher torque can be used for rigid tapping
 Δ connection for high speed: higher torque can be used for high-speed drilling

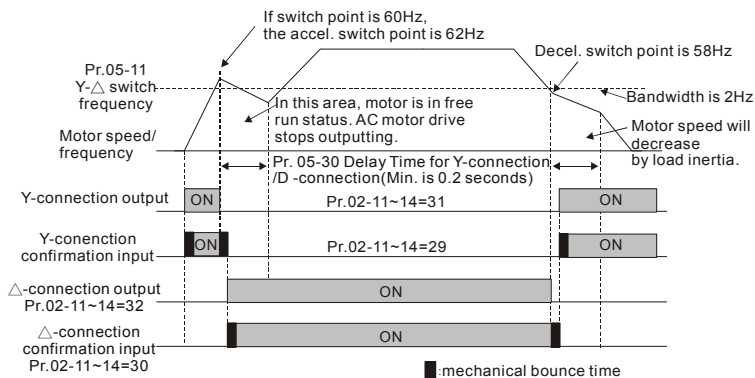
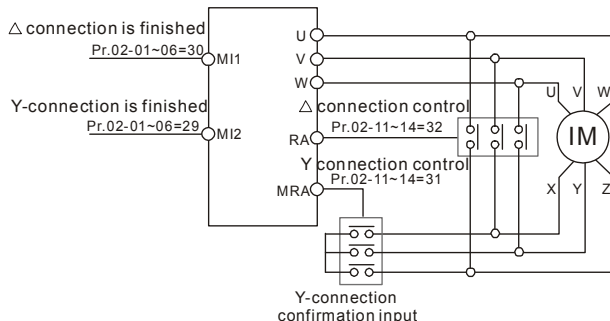

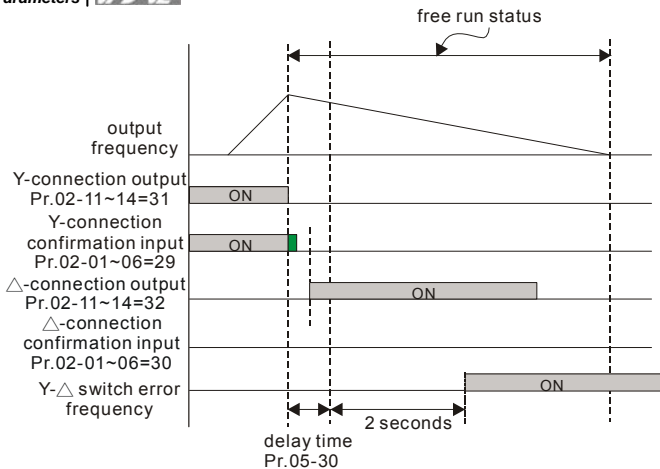
**05-13** Full-load Current of Motor 2(A)

Unit: Amp

Control mode	VF	VFP	SVC	FOCPG	TQCPG	Factory setting: ###
Settings			40 to 120%			

This value should be set according to the rated frequency of the motor as indicated on the motor nameplate. The factory setting is 90% X rated current.

Example: The rated current for 7.5HP (5.5kW) is 25 and factory setting is 22.5A. The range for setting will be 10~30A.(25*40%=10 and 25*120%=30)

05-14 Rated Power of Motor 2 (kW)

Unit: 0.01

Control mode	SVC	FOCPG	TQCPG	Factory setting: ###
Settings		0 to 655.35		

It is used to set rated power of the motor 2. The factory setting is the power of the drive.

05-15 Rated Speed of Motor 2 (rpm)

Unit: 1

Control mode	VFP	SVC	FOCPG	TQCPG	Factory setting: 1710
Settings		0 to 65535			

It is used to set the rated speed of the motor and need to set according to the value indicated on the motor nameplate.

05-16	Number of Motor Poles 2					Unit: 4
Control mode	VF	VFP	SVC	FOCPG	TQCPG	Factory setting: 4
	Settings		2 to 20			

 It is used to set the number of motor poles (must be an even number).

05-17	No-load Current of Motor 2					Unit: Amp
Control mode	VFP	SVC	FOCPG	TQCPG		Factory setting: #.##
	Settings		0 to factory setting of Pr.05-01			

 The factory setting is 40% X rated current.

05-18	Stator Resistance(Rs) of Motor 2					Unit: 0.001
05-19	Rotor Resistance(Rr) of Motor 2					Unit: 0.001
Control mode	SVC	FOCPG	TQCPG			Factory setting: #.###
	Settings		0~65.535Ω			

05-20	Magnetizing Inductance(Lm) of Motor 2					Unit: 0.1
05-21	Stator Inductance (Lx) of Motor 2					Unit: 0.1
Control mode	SVC	FOCPG	TQCPG			Factory setting: #.#
	Settings		0~6553.5mH			

05-22	✓ Torque Compensation Time Constant					Unit: 0.001
Control mode	VF	VFP	SVC			Factory setting: 0.020
	Settings		0.001 to 10.000 sec			

05-23	✓ Slip Compensation Time Constant					Unit: 0.001
Control mode	VFP	SVC				Factory setting: 0.100
	Settings		0.001 to 10.000 sec			

 Setting Pr.05-22 and Pr.05-23 change the response time for the compensation.

 When Pr.05-22 and Pr.05-23 are set to 10.00 seconds, its response time for the compensation will be the longest. But if the settings are too short, unstable system may occur.

05-24	↗ Torque Compensation Gain			Unit: 1
Control mode	VF	VFPG		Factory setting: 0
Settings	0 to10			

 This parameter may be set so that the AC motor drive will increase its voltage output to obtain a higher torque. Only to be used for SVC control mode.

 Too high torque compensation can overheat the motor.

05-25	↗ Slip Compensation Gain			Unit: 0.01
Control mode	VF	SVC		Factory setting: 0.00
Settings	0.00 to10.00			

 When the asynchronous motor is driven by the drive, the load and slip will be increased. This parameter can be used to correct frequency compensation and lower the slip to make the motor can run near the synchronous speed under rated current. When the output current is larger than the motor no-load current, the drive will compensate the frequency by Pr.05-25 setting. If the actual speed is slower than expectation, please increase the setting and vice versa.

 It is only valid in SVC/VF mode.

 The factory settings are:

A. In SVC mode, the factory setting is 1.00.

B. In VF mode, the factory setting is 0.00.

05-26	↗ Slip Deviation Level			Unit: 1
Control mode	VFPG	SVC	FOCPG	Factory setting: 0
Settings	0 to 1000% (0: disable)			

05-27	↗ Detection time of Slip Deviation			Unit: 0.1
Control mode	VFPG	SVC	FOCPG	Factory setting: 1.0
Settings	0.0 to 10.0 sec			

05-28	Over Slip Treatment				Unit: 0
Control mode	VFPG	SVC	FOCPG	Factory setting: 0	
	Settings	0	Warn and keep operation		
		1	Warn and ramp to stop		
		2	Warn and coast to stop		

 **Pr.05-26 to Pr.05-28 are used to set allowable slip level/time and over slip treatment when the drive is running.**

05-29	Hunting Gain			Unit: 1
Control mode	VF	VFPG	SVC	Factory setting: 2000
	Settings	0 to 10000 (0: disable)		

 **The motor will have current wave motion in some specific area. It can improve this situation by setting this parameter. (When it is high frequency or run with PG, Pr.05-29 can be set to 0. when the current wave motion happens in the low frequency, please increase Pr.05-29.)**

05-31	Accumulative Motor Operation Time (Min.)					Unit: 1
Control mode	VF	VFPG	SVC	FOCPG	TQCPG	Factory setting: 00
	Settings	00 to 1439				

05-32	Accumulative Motor Operation Time (Day)					Unit: 1
Control mode	VF	VFPG	SVC	FOCPG	TQCPG	Factory setting: 00
	Settings	00 to 65535				

 **Pr. 05-31 and Pr.05-32 are used to record the motor operation time. They can be cleared by setting to 00 and time won't be recorded when it is less than 60 seconds.**

Group 6 Protection Parameters

06-00 Low Voltage Level

Unit: 0.1

Control mode	VF	VFPG	SVC	FOCPG	TQCPG
Settings	230V series	160.0~220.0Vdc			Factory Setting: 180.0
	460V series	320.0~440.0Vdc			Factory Setting: 360.0

 It is used to set the Lv level.

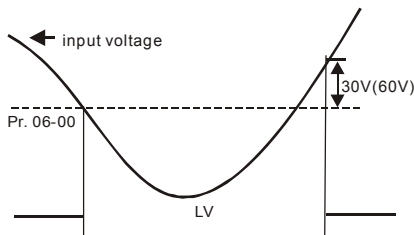
**06-01** Over-Voltage Stall Prevention

Unit: 0.1

Control mode	VF	VFPG	SVC	FOCPG	TQCPG
Settings	230V series	350.0~450.0Vdc			Factory Setting: 380.0
	460V series	700.0~900.0Vdc			Factory Setting: 760.0
		0.0: disable (when brake resistor used)			

 During deceleration, the DC bus voltage may exceed its Maximum Allowable Value due to motor regeneration. When this function is enabled, the AC motor drive will not decelerate further and keep the output frequency constant until the voltage drops below the preset value again.

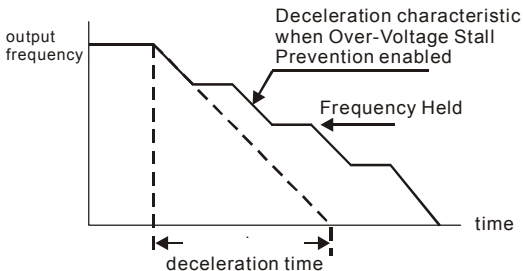

06-02 ✓ Phase-loss Protection

Factory Setting: 0

Control mode	VF	VFPG	SVC	FOCPG	TQCPG	
Settings	0	Warn and keep operation	1	Warn and ramp to stop	2	Warn and coast to stop

 It is used to set the phase-loss treatment. The phase-loss will effect driver's control characteristic and life.

06-03 ✓ Over-Current Stall Prevention during Acceleration

Unit: 1

Factory Setting: 170

Control mode	VF	VFPG	SVC
Settings	00~250% (100%: drive's rated current)		

 During acceleration, the AC drive output current may increase abruptly and exceed the value specified by Pr.06-03 due to rapid acceleration or excessive load on the motor. When this function is enabled, the AC drive will stop accelerating and keep the output frequency constant until the current drops below the maximum value.

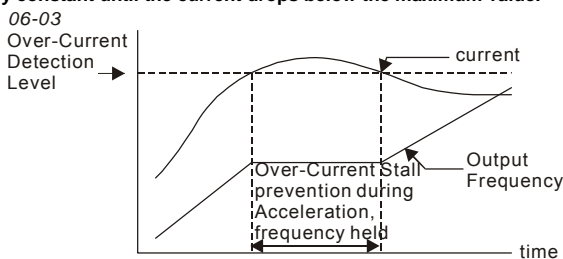

actual acceleration time when over-current stall prevention is enabled

06-04 ✓ Over-current Stall Prevention during Operation

Unit: 1

Factory Setting: 170

Control mode	VF	VFPG	SVC
Settings	00 to 250% (100%: drive's rated current)		

 If the output current exceeds the setting specified in Pr.06-04 when the drive is operating, the drive will decrease its output frequency to prevent the motor stall. If the output current is lower than the setting specified in Pr.06-04, the drive will accelerate again to catch up with the set frequency command value.

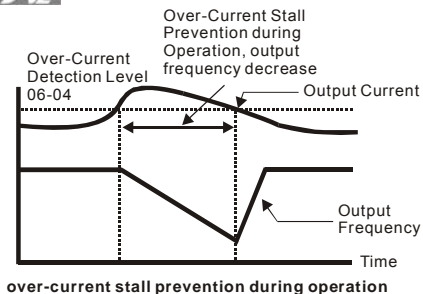
**06-05** **Accel./Decel. Time Selection of Stall Prevention at Constant Speed**

Control mode	VF	VFPG	SVC	Factory Setting: 0
Settings		0	by current accel/decel. time	
		1	by the 1 st accel/decel. time	
		2	by the 2 nd accel/decel. time	
		3	by the 3 rd accel/decel. time	
		4	by the 4 th accel/decel. time	
		5	by auto accel/decel. time	

It is used to set the accel./decel. Time selection when stall prevention occurs at constant speed.

06-06 **Over-torque Detection Selection (OT1)****06-09** **Over-torque Detection Selection (OT2)**

Control mode	VF	VFPG	SVC	FOCPG	TQCPG	Factory Setting: 0
Settings		0	Over-Torque detection disabled.			
		1	Over-torque detection during constant speed operation, continue to operate after detection			
		2	Over-torque detection during constant speed operation, stop operation after detection			
		3	Over-torque detection during operation, continue to operate after detection			
		4	Over-torque detection during operation, stop operation after detection			

When Pr.06-06 and Pr.06-09 are set to 1 or 3, it will display a warning message and won't have an abnormal record.

- When Pr.06-06 and Pr.06-09 are set to 2 or 4, it will display a warning message and will have a abnormal record.

06-07	↗ Over-torque Detection Level (OT1)					Unit: 1
Control mode	VF	VFP	SVC	FOCPG	TQCPG	Factory Setting: 150
Settings	10 to 250% (100%: drive's rated current)					

06-08	↗ Over-torque Detection Time (OT1)					Unit: 0.1
Control mode	VF	VFP	SVC	FOCPG	TQCPG	Factory Setting: 0.1
Settings	0.0 to 60.0 sec					

06-10	↗ Over-torque Detection Level (OT2)					Unit: 1
Control mode	VF	VFP	SVC	FOCPG	TQCPG	Factory Setting: 150
Settings	10 to 250% (100%: drive's rated current)					

06-11	↗ Over-torque Detection Time (OT2)					Unit: 0.1
Control mode	VF	VFP	SVC	FOCPG	TQCPG	Factory Setting: 0.1
Settings	0.0 to 60.0 sec					

- Pr.06-06 and Pr.06-09 determine the operation mode of the drive after the over-torque is detected via the following method: if the output current exceeds the over-torque detection level (Pr.06-19) and also exceeds the Pr.06-08 Over-Torque Detection Time, the fault code "OT1/OT2" is displayed. If a Multi-Functional Output Terminal is to over-torque detection, the output is on. Please refer to Pr.02-11-02-14 for details.

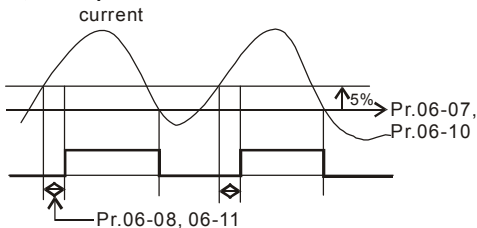

06-12	↗ Current Limit					Unit: 1
Control mode	FOCPG	TQCPG				Factory Setting: 150
Settings	0 to 250% (100%: drive's rated current)					

 **It is used to set the current limit.**

06-13	↗ Electronic Thermal Relay Selection (Motor 1)					Unit: 1
Control mode	VF	VFPG	SVC	FOCPG	TQCPG	Factory Setting: 2
Settings	0	Operate with a Inverter Motor (forced external cooling)				
	1	Operate with a Standard Motor (self-cooled by fan)				
	2	Disabled				

06-27	↗ Electronic Thermal Relay Selection (Motor 2)					Unit: 1
Control mode	VF	VFPG	SVC	FOCPG	TQCPG	Factory Setting: 2
Settings	0	Operate with a Inverter Motor (forced external cooling)				
	1	Operate with a Standard Motor (self-cooled by fan)				
	2	Disabled				

 **It is used to prevent self-cooled motor overheats under low speed. User can use electrical thermal relay to limit driver's output power.**

06-14	↗ Electronic Thermal Characteristic for Motor 1					Unit: 0.1
Control mode	VF	VFPG	SVC	FOCPG	TQCPG	Factory Setting: 60.0
Settings	30.0 to 600.0 sec					

06-28	↗ Electronic Thermal Characteristic for Motor 2					Unit: 0.1
Control mode	VF	VFPG	SVC	FOCPG	TQCPG	Factory Setting: 60.0
Settings	30.0 to 600.0 sec					

 **The parameter is set by the 150% of motor rated current and the setting of Pr.06-14 and Pr.06-28 to prevent the motor damaged from overheating. When it reaches the setting, it will display "EoL1/EoL2" and the motor will be in free running.**

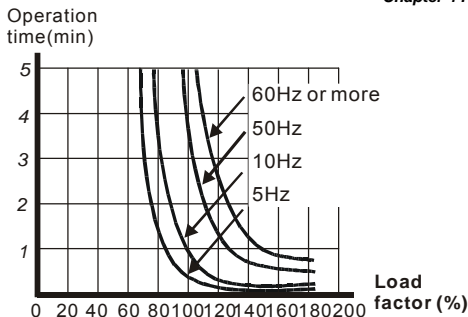

06-15 ✓ Heat Sink Over-heat (OH) Warning Unit: 0.1

Control mode: VF VFPG SVC FOC PG TQCPG Factory Setting: 85.0

Settings: 0.0 to 110.0 °C

06-16 ✓ Stall Prevention Limit Level Unit: 1

Control mode: VF VFPG SVC Factory Setting: 50

Settings: 0 to 100% (refer to Pr.06-03, Pr.06-04)

📖 When operation frequency is larger than Pr.01-01, Pr06-03=150%, Pr. 06-04=100% and Pr.

06-16=80%:

Stall Prevention Level during acceleration = $06-03 \times 06-16 = 150 \times 80\% = 120\%$.

Stall Prevention Level at constant speed = $06-04 \times 06-16 = 100 \times 80\% = 80\%$.

06-17 Present Fault Record

06-18 Second Most Recent Fault Record

06-19 Third Most Recent Fault Record

06-20 Fourth Recent Fault Record

06-21 Fifth Most Recent Fault Record

06-22 Sixth Most Recent Fault Record

Settings: 0 to 65

Factory Setting: 0

Settings	Control Mode				
	VF	VFPG	SVC	FOCPG	TQCPG
0: No fault	○	○	○	○	○
1: Over-current during acceleration (ocA)	○	○	○	○	○
2: Over-current during deceleration (ocd)	○	○	○	○	○
3: Over-current during constant speed (ocn)	○	○	○	○	○
4: Ground fault (GFF)	○	○	○	○	○

Settings	Control Mode				
	VF	VFPG	SVC	FOCPG	TQCPG
5: IGBT short-circuit (occ)	<input type="checkbox"/>	<input type="checkbox"/>	<input type="checkbox"/>	<input type="checkbox"/>	<input type="checkbox"/>
6: Over-current at stop (ocS)	<input type="checkbox"/>	<input type="checkbox"/>	<input type="checkbox"/>	<input type="checkbox"/>	<input type="checkbox"/>
7: Over-voltage during acceleration (ovA)	<input type="checkbox"/>	<input type="checkbox"/>	<input type="checkbox"/>	<input type="checkbox"/>	<input type="checkbox"/>
8: Over-voltage during deceleration (ovd)	<input type="checkbox"/>	<input type="checkbox"/>	<input type="checkbox"/>	<input type="checkbox"/>	<input type="checkbox"/>
9: Over-voltage during constant speed (ovn)	<input type="checkbox"/>	<input type="checkbox"/>	<input type="checkbox"/>	<input type="checkbox"/>	<input type="checkbox"/>
10: Over-voltage at stop (ovS)	<input type="checkbox"/>	<input type="checkbox"/>	<input type="checkbox"/>	<input type="checkbox"/>	<input type="checkbox"/>
11: Low-voltage during acceleration (LvA)	<input type="checkbox"/>	<input type="checkbox"/>	<input type="checkbox"/>	<input type="checkbox"/>	<input type="checkbox"/>
12: Low-voltage during deceleration (Lvd)	<input type="checkbox"/>	<input type="checkbox"/>	<input type="checkbox"/>	<input type="checkbox"/>	<input type="checkbox"/>
13: Low-voltage during constant speed (Lvn)	<input type="checkbox"/>	<input type="checkbox"/>	<input type="checkbox"/>	<input type="checkbox"/>	<input type="checkbox"/>
14: Low-voltage at stop (LvS)	<input type="checkbox"/>	<input type="checkbox"/>	<input type="checkbox"/>	<input type="checkbox"/>	<input type="checkbox"/>
15: Phase loss (PHL)	<input type="checkbox"/>	<input type="checkbox"/>	<input type="checkbox"/>	<input type="checkbox"/>	<input type="checkbox"/>
16: IGBT over-heat (oH1)	<input type="checkbox"/>	<input type="checkbox"/>	<input type="checkbox"/>	<input type="checkbox"/>	<input type="checkbox"/>
17: Heat sink over-heat (oH2)(for 40HP above)	<input type="checkbox"/>	<input type="checkbox"/>	<input type="checkbox"/>	<input type="checkbox"/>	<input type="checkbox"/>
18: TH1: IGBT hardware failure (tH1o)	<input type="checkbox"/>	<input type="checkbox"/>	<input type="checkbox"/>	<input type="checkbox"/>	<input type="checkbox"/>
19: TH2: Heat sink hardware failure(tH2o)	<input type="checkbox"/>	<input type="checkbox"/>	<input type="checkbox"/>	<input type="checkbox"/>	<input type="checkbox"/>
20: Fan error signal output	<input type="checkbox"/>	<input type="checkbox"/>	<input type="checkbox"/>	<input type="checkbox"/>	<input type="checkbox"/>
21: over-load (oL) (when it exceeds 150% rated current, 1 min later it will be overload)	<input type="checkbox"/>	<input type="checkbox"/>	<input type="checkbox"/>	<input type="checkbox"/>	<input type="checkbox"/>
22: Electronics thermal relay 1 (EoL1)	<input type="checkbox"/>	<input type="checkbox"/>	<input type="checkbox"/>	<input type="checkbox"/>	<input type="checkbox"/>
23: Electronics thermal relay 2 (EoL2)	<input type="checkbox"/>	<input type="checkbox"/>	<input type="checkbox"/>	<input type="checkbox"/>	<input type="checkbox"/>
24: Motor PTC overheat (oH3)	<input type="checkbox"/>	<input type="checkbox"/>	<input type="checkbox"/>	<input type="checkbox"/>	<input type="checkbox"/>
25: Fuse error (FuSE)	<input type="checkbox"/>	<input type="checkbox"/>	<input type="checkbox"/>	<input type="checkbox"/>	<input type="checkbox"/>
26: over-torque 1 (ot1)	<input type="checkbox"/>	<input type="checkbox"/>	<input type="checkbox"/>	<input type="checkbox"/>	<input type="checkbox"/>
27: over-torque 1 (ot2)	<input type="checkbox"/>	<input type="checkbox"/>	<input type="checkbox"/>	<input type="checkbox"/>	<input type="checkbox"/>
28: Reserved					
29: Reserved					
30: Memory write-in error (cF1)	<input type="checkbox"/>	<input type="checkbox"/>	<input type="checkbox"/>	<input type="checkbox"/>	<input type="checkbox"/>
31: Memory read-out error (cF2)	<input type="checkbox"/>	<input type="checkbox"/>	<input type="checkbox"/>	<input type="checkbox"/>	<input type="checkbox"/>
32: Isum current detection error (cd0)	<input type="checkbox"/>	<input type="checkbox"/>	<input type="checkbox"/>	<input type="checkbox"/>	<input type="checkbox"/>
33: U-phase current detection error (cd1)	<input type="checkbox"/>	<input type="checkbox"/>	<input type="checkbox"/>	<input type="checkbox"/>	<input type="checkbox"/>
34: V-phase current detection error (cd2)	<input type="checkbox"/>	<input type="checkbox"/>	<input type="checkbox"/>	<input type="checkbox"/>	<input type="checkbox"/>
35: W-phase current detection error (cd3)	<input type="checkbox"/>	<input type="checkbox"/>	<input type="checkbox"/>	<input type="checkbox"/>	<input type="checkbox"/>
36: Clamp current detection error (Hd0)	<input type="checkbox"/>	<input type="checkbox"/>	<input type="checkbox"/>	<input type="checkbox"/>	<input type="checkbox"/>
37: Over-current detection error (Hd1)	<input type="checkbox"/>	<input type="checkbox"/>	<input type="checkbox"/>	<input type="checkbox"/>	<input type="checkbox"/>
38: Over-voltage detection error (Hd2)	<input type="checkbox"/>	<input type="checkbox"/>	<input type="checkbox"/>	<input type="checkbox"/>	<input type="checkbox"/>
39: Ground current detection error (Hd3)	<input type="checkbox"/>	<input type="checkbox"/>	<input type="checkbox"/>	<input type="checkbox"/>	<input type="checkbox"/>
40: Auto tuning error (AuE)				<input type="checkbox"/>	<input type="checkbox"/>
41: PID feedback loss (AFE)	<input type="checkbox"/>	<input type="checkbox"/>	<input type="checkbox"/>	<input type="checkbox"/>	<input type="checkbox"/>
42: PG feedback error (PGF1)		<input type="checkbox"/>		<input type="checkbox"/>	<input type="checkbox"/>
43: PG feedback loss (PGF2)		<input type="checkbox"/>		<input type="checkbox"/>	<input type="checkbox"/>
44: PG feedback stall (PGF3)		<input type="checkbox"/>		<input type="checkbox"/>	<input type="checkbox"/>
45: PG slip error (PGF4)		<input type="checkbox"/>		<input type="checkbox"/>	<input type="checkbox"/>
46: PG ref input error (PGr1)	<input type="checkbox"/>	<input type="checkbox"/>	<input type="checkbox"/>	<input type="checkbox"/>	<input type="checkbox"/>
47: PG ref loss (PGr2)	<input type="checkbox"/>	<input type="checkbox"/>	<input type="checkbox"/>	<input type="checkbox"/>	<input type="checkbox"/>
48: Analog current input loss (ACE)	<input type="checkbox"/>	<input type="checkbox"/>	<input type="checkbox"/>	<input type="checkbox"/>	<input type="checkbox"/>
49: External fault input (EF)	<input type="checkbox"/>	<input type="checkbox"/>	<input type="checkbox"/>	<input type="checkbox"/>	<input type="checkbox"/>
50: Emergency stop (EF1)	<input type="checkbox"/>	<input type="checkbox"/>	<input type="checkbox"/>	<input type="checkbox"/>	<input type="checkbox"/>
51: External Base Block (B.B.)	<input type="checkbox"/>	<input type="checkbox"/>	<input type="checkbox"/>	<input type="checkbox"/>	<input type="checkbox"/>
52: Password error (PcodE)	<input type="checkbox"/>	<input type="checkbox"/>	<input type="checkbox"/>	<input type="checkbox"/>	<input type="checkbox"/>
53: Reserved					
54: Communication error (cE1)	<input type="checkbox"/>	<input type="checkbox"/>	<input type="checkbox"/>	<input type="checkbox"/>	<input type="checkbox"/>
55: Communication error (cE2)	<input type="checkbox"/>	<input type="checkbox"/>	<input type="checkbox"/>	<input type="checkbox"/>	<input type="checkbox"/>

Settings	Control Mode				
	VF	VFPG	SVC	FOCPG	TQCPG
56: Communication error (cE3)	○	○	○	○	○
57: Communication error (cE4)	○	○	○	○	○
58: Communication Time-out (cE10)	○	○	○	○	○
59: PU time-out (cP10)	○	○	○	○	○
60: Brake transistor error (bF)	○	○	○	○	○
61: Y-connection/ Δ -connection switch error (ydc)	○	○	○	○	○
62: Decel. Energy Backup Error (dEb)	○	○	○	○	○
63: Slip error (oS _L)	○	○	○	○	○
64: Broken belt error (bEb)	○	○	○	○	○
65: Error PID feedback signal of tension (tdEv)	○	○	○	○	○

 It will record when the fault occurs and force stopping. For the Lv, it will record when it is operation, or it will warn without record.

 Setting 62: when DEB function is enabled, the drive will execute DEB and record to the Pr.06-17 to Pr.06-22 simultaneously.

06-23	✗ Fault Output Option 1	Unit: 1
06-24	✗ Fault Output Option 2	Unit: 1
06-25	✗ Fault Output Option 3	Unit: 1
06-26	✗ Fault Output Option 4	Unit: 1

Control mode	VF	VFPG	SVC	FOCPG	TQCPG	Factory Setting: 0
Settings						0 to 65535 sec (refer to bit table for fault code)

 These parameters can be used with multi-function output (set Pr.02-11 to Pr.02-14 to 35-38) for the specific requirement. When the fault occurs, the corresponding terminals will be activated (It needs to convert binary value to decimal value to fill in Pr.06-23 to Pr.06-26).

Fault code	Bit0	Bit1	Bit2	Bit3	Bit4	Bit5	Bit6
	current	Volt.	OL	SYS	FBK	EXI	CE
0: No fault							
1: Over-current during acceleration (ocA)	●						
2: Over-current during deceleration (ocd)	●						
3: Over-current during constant speed (ocn)	●						
4: Ground fault (GFF)						●	

Fault code	Bit0	Bit1	Bit2	Bit3	Bit4	Bit5	Bit6
	current	Volt.	OL	SYS	FBK	EXI	CE
5: IGBT short-circuit (occ)	●						
6: Over-current at stop (ocS)	●						
7: Over-voltage during acceleration (ovA)		●					
8: Over-voltage during deceleration (ovd)		●					
9: Over-voltage during constant speed (ovn)		●					
10: Over-voltage at stop (ovS)		●					
11: Low-voltage during acceleration (LvA)		●					
12: Low-voltage during deceleration (Lvd)		●					
13: Low-voltage during constant speed (Lvn)		●					
14: Low-voltage at stop (LvS)		●					
15: Phase loss (PHL)						●	
16: IGBT over-heat (oH1)			●				
17: Heat sink over-heat (oH2)(for 40HP above)			●				
18: TH1: IGBT hardware failure (tH1o)			●				
19: TH2: Heat sink hardware failure(tH2o)			●				
20: Fan error signal output						●	
21: over-load (oL) (when it exceeds 150% rated current, 1 min later it will be overload)			●				
22: Electronics thermal relay 1 (EoL1)			●				
23: Electronics thermal relay 2 (EoL2)			●				
24: Motor PTC overheat (oH3)			●				
25: Fuse error (FuSE)						●	

Fault code	Bit0	Bit1	Bit2	Bit3	Bit4	Bit5	Bit6
	current	Volt.	OL	SYS	FBK	EXI	CE
26: over-torque 1 (ot1)			●				
27: over-torque 1 (ot2)			●				
28: Reserved							
29: Reserved							
30: Memory write-in error (cF1)				●			
31: Memory read-out error (cF2)				●			
32: Isum current detection error (cd0)				●			
33: U-phase current detection error (cd1)				●			
34: V-phase current detection error (cd2)				●			
35: W-phase current detection error (cd3)				●			
36: Clamp current detection error (Hd0)				●			
37: Over-current detection error (Hd1)				●			
38: Over-voltage detection error (Hd2)				●			
39: Ground current detection error (Hd3)				●			
40: Auto tuning error (AuE)				●			
41: PID feedback loss (AFE)					●		
42: PG feedback error (PGF1)					●		
43: PG feedback loss (PGF2)					●		
44: PG feedback stall (PGF3)					●		
45: PG slip error (PGF4)					●		
46: PG ref input error (PGr1)					●		
47: PG ref loss (PGr2)					●		
48: Analog current input loss (ACE)					●		

Fault code	Bit0	Bit1	Bit2	Bit3	Bit4	Bit5	Bit6
	current	Volt.	OL	SYS	FBK	EXI	CE
49: External fault input (EF)						●	
50: Emergency stop (EF1)						●	
51: External Base Block (B.B.)						●	
52: Password error (PcodE)				●			
53: Reserved							
54: Communication error (cE1)							●
55: Communication error (cE2)							●
56: Communication error (cE3)							●
57: Communication error (cE4)							●
58: Communication Time-out (cE10)							●
59: PU time-out (cP10)							●
60: Brake transistor error (bF)						●	
61: Y-connection/ Δ -connection switch error (ydc)						●	
62: Decel. Energy Backup Error (dEb)		●					
63: Slip error (oSL)						●	
64: Broken belt error (bEb)						●	
65: Error PID feedback signal of tension (tdEv)						●	

06-29  PTC (Positive Temperature Coefficient) Detection Selection

Control mode	VF	VFPG	SVC	FOCPG	TQCPG	Factory Setting: 0
Settings		0			Warn and keep operating	
		1			Warn and ramp to stop	
		2			Warn and coast to stop	

 **It is used to set the treatment after detecting PTC.**

06-30	↗ PTC Level					Unit: 0.1
Control mode	VF	VFPG	SVC	FOCPG	TQCPG	Factory Setting: 50.0
	Settings		0.0 to 100.0%			

 It is used to set the PTC level, and the corresponding value for 100% is max. analog input value.

06-31	↗ Filter Time for PTC Detection					Unit: 0.01
Control mode	VF	VFPG	SVC	FOCPG	TQCPG	Factory Setting: 0.20
	Settings		0.00 to 10.00 sec			

06-32	Output Frequency for Malfunction					
Control mode	VF	VFPG	SVC	FOCPG	TQCPG	Factory Setting: Read-only
	Settings		0.00 to 655.35 Hz			

06-33	Output Voltage for Malfunction					
Control mode	VF	VFPG	SVC	FOCPG	TQCPG	Factory Setting: Read-only
	Settings		0.0~6553.5 V			

06-34	DC Voltage for Malfunction					
Control mode	VF	VFPG	SVC	FOCPG	TQCPG	Factory Setting: Read-only
	Settings		0.0~6553.5 V			

06-35	Output Current for Malfunction					
Control mode	VF	VFPG	SVC	FOCPG	TQCPG	Factory Setting: Read-only
	Settings		0.00~655.35 Amp			

06-36	IGBT Temperature for Malfunction					
Control mode	VF	VFPG	SVC	FOCPG	TQCPG	Factory Setting: Read-only
	Settings		0.0~6553.5 °C			

Group 7 Special Parameters

07-00	↗ Software Brake Level	Unit: 0.1
--------------	------------------------	-----------

Control mode	VF	VFPG	SVC	FOCPG	TQCPG	
Settings	230V series	350.0~450.0Vdc				Factory Setting: 380.0
	460V series	700.0~900.0Vdc				Factory Setting: 760.0

 **This parameter sets the DC-bus voltage at which the brake chopper is activated.**

07-01	↗ DC Brake Current Level	Unit: 1
--------------	--------------------------	---------

Control mode	VF	VFPG	SVC	FOCPG	TQCPG	
Settings	0 to 100%					Factory Setting: 0

 **This parameter sets the level of DC Brake Current output to the motor during start-up and stopping. When setting DC Brake Current, the Rated Current (Pr.00-01) is regarded as 100%. It is recommended to start with a low DC Brake Current Level and then increase until proper holding torque has been attained.**

 **When it is in FOCPG/TQCPG mode, DC brake is zero-speed operation. It can enable DC brake function by setting to any value.**

07-02	↗ DC Brake Time at Start-up	Unit: 0.1
--------------	-----------------------------	-----------

Control mode	VF	VFPG	SVC	FOCPG	TQCPG	
Settings	0.0 to 60.0 sec					Factory Setting: 0.0

 **This parameter determines the duration of the DC Brake current after a RUN command. When the time has elapsed, the AC motor drive will start accelerating from the Minimum Frequency (Pr.01-05).**

07-03	↗ DC Brake Time at Stop	Unit: 0.01
--------------	-------------------------	------------

Control mode	VF	VFPG	SVC	FOCPG	TQCPG	
Settings	0.00 to 60.00 sec					Factory Setting: 0.00



 **This parameter determines the duration of the DC Brake current during stopping.**

07-04	↗ Start-Point for DC Brake	Unit: 0.01
--------------	----------------------------	------------

Control mode	VF	VFPG	SVC	TQCPG	
Settings	0.00 to 600.00Hz				Factory Setting: 0.00

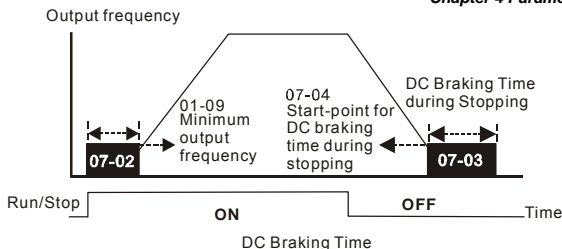
 **This parameter determines the frequency when DC Brake will begin during deceleration.**





-  **DC Brake at Start-up** is used for loads that may move before the AC drive starts, such as fans and pumps. Under such circumstances, DC Brake can be used to hold the load in position before setting it in motion.
-  **DC Brake at stop** is used to shorten the stopping time and also to hold a stopped load in position. For high inertia loads, a dynamic brake resistor may also be needed for fast decelerations.

07-05	Proportional Gain for DC Brake			Unit: 1
Control mode	VF	VFPG	SVC	Factory Setting: 50
Settings	1 to 500Hz			

-  It is used to set the output voltage gain when DC brake.

07-06	Momentary Power Loss Operation Selection					Factory Setting: 0
Control mode	VF	VFPG	SVC	FOCPG	TQCPG	
Settings	0					Operation stops after momentary power loss.
	1					Operation continues after momentary power loss, speed search starts with the Master Frequency reference value.
	2					Operation continues after momentary power loss, speed search starts with the minimum frequency.

-  This parameter determines the operation mode when the AC motor drive restarts from a momentary power loss.
-  In PG control mode, the AC motor drive will execute the speed search function automatically by the PG speed when this setting isn't set to 0.

07-07 Maximum Allowable Power Loss Time

Unit: 0.1

Control mode: VF VFPG SVC FOCPG TQCPG

Factory Setting: 2.0

Settings: 0.1 to 5.0 sec

- If the duration of a power loss is less than this parameter setting, the AC motor drive will resume operation. If it exceeds the Maximum Allowable Power Loss Time, the AC motor drive output is then turned off (coast stop).**
- The selected operation after power loss in Pr.07-06 is only executed when the maximum allowable power loss time is ≤ 5 seconds and the AC motor drive displays “Lu”.**
- But if the AC motor drive is powered off due to overload, even if the maximum allowable power loss time is ≤ 5 seconds, the operation mode as set in Pr.07-06 is not executed. In that case it starts up normally.**

07-08 Baseblock Time for Speed Search (BB)

Unit: 0.1

Control mode: VF VFPG SVC FOCPG TQCPG

Factory Setting: 0.5

Settings: 0.1 to 5.0 sec

- When momentary power loss is detected, the AC drive will block its output and then wait for a specified period of time (determined by Pr.07-08, called Base-Block Time) before resuming operation. This parameter should be set at a value to ensure that any residual regeneration voltage from the motor on the output has disappeared before the drive is activated again.**

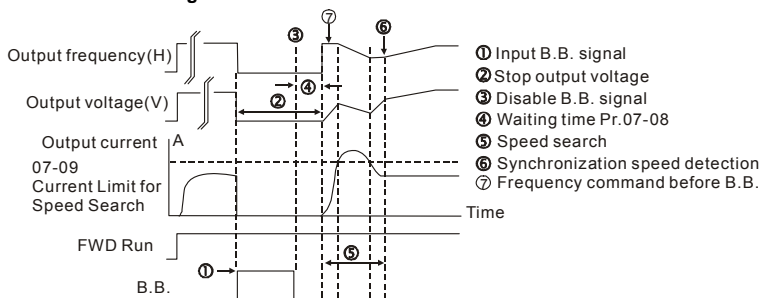

B.B. Search with last output frequency downward timing chart

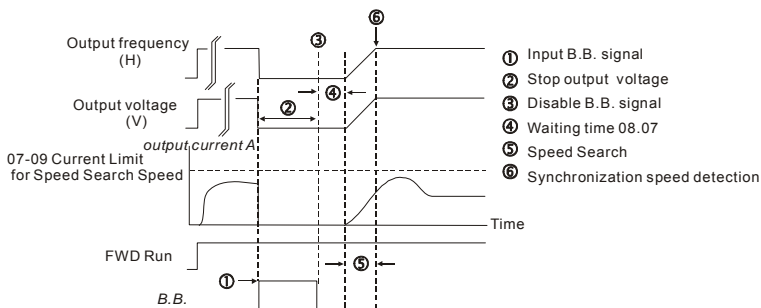

B.B. Search with minimum output frequency upward timing chart

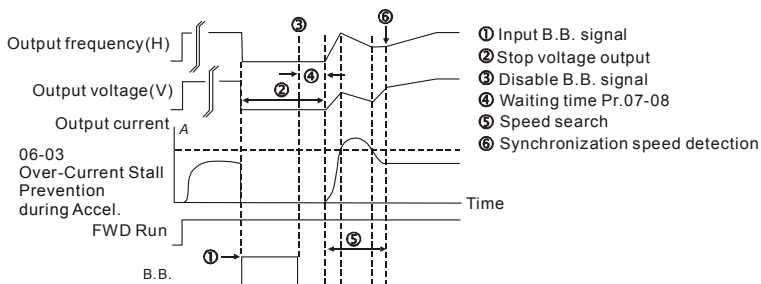

B.B. Search with minimum output frequency upward timing chart

07-09 Current Limit for Speed Search

Unit: 1

Control mode VF VFG SVC FOC PG TQCPG

Factory Setting: 150

Settings 20 to 200%

Following a momentary power loss, the AC motor drive will start its speed search operation only if the output current is greater than the value set by Pr.8-07. When the output current is less than the value of Pr.8-07, the AC motor drive output frequency is at "speed synchronization point". The drive will start to accelerate or decelerate back to the operating frequency at which it was running prior to the power loss.

When executing speed search, the V/f curve is operated by group 1 setting. The maximum current for the optimum accel./decel. and start speed search is set by Pr.07-09.

07-10  Base Block Speed Search

Control mode	VF	VFPG	SVC	FOCPG	TQCPG	Factory Setting: 0
--------------	----	------	-----	-------	-------	--------------------

Settings	0	Stop operation			
	1	Speed search starts with last frequency command			
	2	Speed search starts with minimum output frequency			

 **This parameter determines the AC motor drive restart method after External Base Block is enabled.**

 **In PG control mode, the AC motor drive will execute the speed search function automatically by the PG speed when this setting isn't set to 0.**

07-11  Auto Restart After Fault

Unit: 1

Control mode	VF	VFPG	SVC	FOCPG	TQCPG	Factory Setting: 0
--------------	----	------	-----	-------	-------	--------------------

Settings	0 to 10				
----------	---------	--	--	--	--

 **Only after an over-current OC or over-voltage OV fault occurs, the AC motor drive can be reset/restarted automatically up to 10 times.**

 **Setting this parameter to 0 will disable the reset/restart operation after any fault has occurred.**

When enabled, the AC motor drive will restart with speed search, which starts at the frequency before the fault. To set the waiting time before restart after a fault, please set Pr. 07-08 Base Block Time for Speed Search.

07-12  Speed Search during Start-up

Control mode	VF	VFPG	SVC	FOCPG	TQCPG	Factory Setting: 0
--------------	----	------	-----	-------	-------	--------------------

Settings	0	Disable			
	1	Speed search from maximum frequency			
	2	Speed search from start-up frequency			
	3	Speed search from minimum frequency			

 **This parameter is used for starting and stopping a motor with high inertia. A motor with high inertia will take a long time to stop completely. By setting this parameter, the user does not need to wait for the motor to come to a complete stop before restarting the AC motor drive. If a PG card and encoder is used on the drive and motor, then the speed**

search will start from the speed that is detected by the encoder and accelerate quickly to the commanded frequency. The output current is set by the Pr.07-09.



In PG control mode, the AC motor drive will execute the speed search function automatically by the PG speed when this setting isn't set to 0.

07-13		Decel. Time Selection for Momentary Power Loss (DEB function)				Factory Setting: 0
Control mode	VF	VFPG	SVC	FOCPG	TQCPG	
	Settings	0	Disable			
		1	1st decel. time			
		2	2nd decel. time			
		3	3rd decel. time			
		4	4th decel. time			
		5	Current decel. time			
		6	Auto decel. time			



This parameter is used for the decel. time selection for momentary power loss.

07-14		DEB Return Time				Unit: 0.1
Control mode	VF	VFPG	SVC	FOCPG		Factory Setting: 0.0
	Settings	0.0 to 25.0 sec				



The DEB (Deceleration Energy Backup) function is the AC motor drive decelerates to stop after momentary power loss. When the momentary power loss occurs, this function can be used for the motor to decelerate to 0 speed with deceleration stop method. When the power is on again, motor will run again after DEB return time.



Status 1: Insufficient power supply due to momentary power-loss/unstable power (due to low voltage)/sudden heavy-load

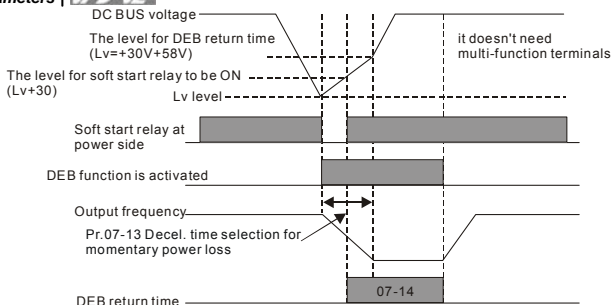

NOTE

When Pr.07-14 is set to 0, the AC motor drive will be stopped and won't re-start at the power-on again.

Status 2: unexpected power off, such as momentary power loss

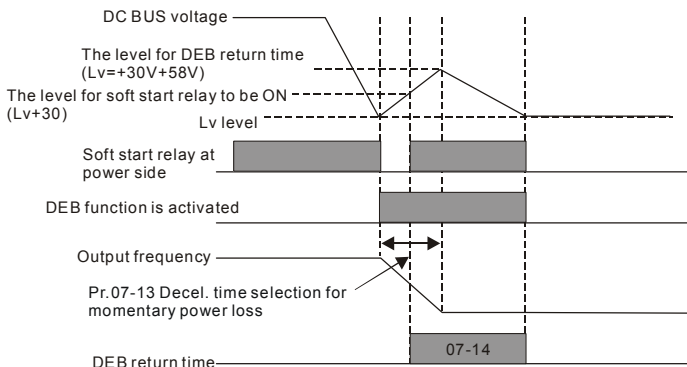

NOTE

For example, in textile machinery, you will hope that all the machines can be decelerated to stop to prevent broken stitching when power loss. In this case, the host controller will send a message to the AC motor drive to use DEB function with deceleration time via EF.

07-15 \swarrow Dwell Time at Accel.

Unit: 0.01

Control mode VF VFPG SVC FOC PG

Factory Setting: 0.00

Settings 0.00 to 600.00 sec

07-16	/ Dwell Frequency at Accel.				Unit: 0.01
Control mode	VF	VFPG	SVC	FOCPG	Factory Setting: 0.00
	Settings		0.00 to 600.00 Hz		
07-17	/ Dwell Time at Decel.				Unit: 0.01
Control mode	VF	VFPG	SVC	FOCPG	Factory Setting: 0.00
	Settings		0.00 to 600.00 sec		
07-18	/ Dwell Frequency at Decel.				Unit: 0.01
Control mode	VF	VFPG	SVC	FOCPG	Factory Setting: 0.00
	Settings		0.00 to 600.00 Hz		

 **In the heavy load situation, Dwell can make stable output frequency temporarily.**

 **Pr.07-15 to Pr.07-18 is for heavy load to prevent OV or OC occurs.**

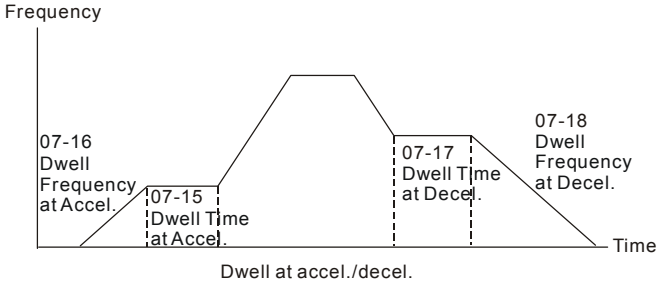

07-19	/ Fan Control					Factory Setting: 0
Control mode	VF	VFPG	SVC	FOCPG	TQCPG	
	Settings		0 Fan always ON			
			1 1 minute after AC motor drive stops, fan will be OFF			
			2 AC motor drive runs and fan ON, AC motor drive stops and fan OFF			
			3 Fan ON to run when preliminary heat sink temperature (around 60°C) attained			
			4 Fan always OFF			

 **This parameter is used for the fan control.**

07-20 ⚡ Torque Command

Unit: 0.1

Control mode	TQCPG	Factory Setting: 0.0
Settings	-100.0 to 100.0% (Pr. 07-22 setting=100%)	

 This parameter is torque command. When Pr.07-22 is 250% and Pr.07-20 is 100%, the actual torque command = 250%×100% X motor rated torque.

 The drive will record the setting before power off.

07-21 ⚡ Torque Command Source

Control mode	TQCPG	Factory Setting: 0
Settings	0	Digital keypad
	1	RS485 serial communication (RJ-11)
	2	Analog signal (Pr.03-00)

 When Pr.07-21 is set to 0, the torque command can be set in Pr.07-20.

 When Pr.07-21 is set to 1 or 2, Pr.07-20 is used to display torque command.

07-22 ⚡ Maximum Torque Command

Unit: 1

Control mode	TQCPG	Factory Setting: 100
Settings	0 to 500%	

 This parameter is for the max. torque command (motor rated torque is 100%).

 According to the formula of motor rated torque: $T(N.M) = \frac{P(\omega)}{W(rad/s)}$, where $P(\omega)$ is

$$\text{Pr.05-02 and } W(\text{rad/s}) \text{ is Pr.05-03. } \frac{RPM}{60 \times 2\pi} = \text{rad/s}$$

07-23 ⚡ Filter Time of Torque Command

Unit: 0.001

Control mode	TQCPG	Factory Setting: 0.000
Settings	0.000 to 1.000 sec	

 When the setting is too long, the control will be stable but the control response will be delay. When the setting is too short, the response will be quickly but the control maybe unstable. User can adjust the setting by the control and response situation.

07-24 Speed Limit Selection

Control mode	TQCPG	Factory Setting: 0
---------------------	--------------	--------------------

Settings	0	By Pr.07-25 and Pr.07-26
	1	Frequency command source (Pr.00-20)

The function of speed limit: In the torque control mode (TQCPG), when the torque command is larger than the load, it will be changed to speed control mode while the motor speed is accelerated to speed limit setting (Pr.07-24, Pr.07-25 and Pr.07-26) to prevent the motor from continuous acceleration.

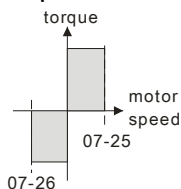

Pr.07-24=0

Running/opposite running direction are limited by Pr.07-25 and Pr.07-26.

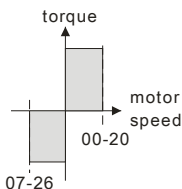

Pr.07-24=1

When it is forward running, the running direction is limited by Pr.00-20 and the opposite running direction is limited by Pr.07-26.

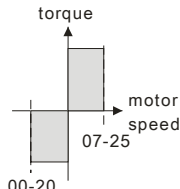

Pr.07-24=1

When it is reverse running, the running direction is limited by Pr.07-25 and the opposite running direction is limited by Pr.00-20.

07-25 ✓ Torque Mode +Speed Limit

Unit: 1

07-26 ✓ Torque Mode-Speed Limit

Unit: 1

Control mode	TQCPG	Factory Setting: 10
---------------------	--------------	---------------------

Settings	0 to 120%
----------	-----------

These parameters are used in the torque mode to limit the running direction and opposite direction. (Pr.01-00 max. output frequency=100%)

07-27 Source of Torque Offset

Control mode	SVC FOC PG TQCPG	Factory Setting: 0
---------------------	-------------------------	--------------------

Settings	0	Disable
	1	Analog input (Pr.03-00)
	2	Torque offset setting
	3	Control by external terminal (by Pr.07-29 to Pr.07-31)

This parameter is the source of torque offset.

When it is set to 3, the source of torque offset will decide to Pr.07-29, Pr.07-30 and Pr.07-31 by the multi-function input terminals(MI) setting (31, 32 or 33).

MI is set to 31	MI is set to 32	MI is set to 33	Torque offset
OFF	OFF	OFF	None
OFF	OFF	ON	07-31
OFF	ON	OFF	07-30
OFF	ON	ON	07-31+07-30
ON	OFF	OFF	07-29
ON	OFF	ON	07-29+07-31
ON	ON	OFF	07-29+07-30
ON	ON	ON	07-29+07-30+07-31

07-28 Torque Offset Setting

Unit: 0.1

Control mode	SVC	FOCPG	TQCPG
--------------	-----	-------	-------

Factory Setting: 0.0

Settings 0.0 to 100.0%

This parameter is torque offset. The motor rated torque is 100%.

According to the formula of motor rated torque: $T(N.M) = \frac{P(\omega)}{W(rad/s)}$, where $P(\omega)$ is

$$\text{Pr.05-02 and } W(\text{rad/s}) \text{ is Pr.05-03. } \frac{RPM}{60 \times 2\pi} = \text{rad/s}$$

07-29 High Torque Offset

Unit: 0.1

Control mode	SVC	FOCPG	TQCPG
--------------	-----	-------	-------

Factory Setting: 30.0

Settings 0.0 to 100.0%

07-30 Middle Torque Offset

Unit: 0.1

Control mode	SVC	FOCPG	TQCPG
--------------	-----	-------	-------

Factory Setting: 20.0

Settings 0.0 to 100.0%

07-31 Low Torque Offset

Unit: 0.1

Control mode	SVC	FOCPG	TQCPG
--------------	-----	-------	-------

Factory Setting: 10.0

Settings 0.0 to 100.0%

 When it is set to 3, the source of torque offset will decide to Pr.07-29, Pr.07-30 and Pr.07-31 by the multi-function input terminals setting (31, 32 or 33). The motor rated torque is 100%.

 According to the formula of motor rated torque: $T(N.M) = \frac{P(\omega)}{W(rad/s)}$, where $P(\omega)$ is

$$\text{Pr.05-02 and } W(\text{rad/s}) \text{ is Pr.05-03. } \frac{RPM}{60 \times 2\pi} = \text{rad/s}$$

07-32	✓ Forward Motor Torque Limit	Unit: 1
07-33	✓ Forward Regenerative Torque Limit	Unit: 1
07-34	✓ Reverse Motor Torque Limit	Unit: 1
07-35	✓ Reverse Regenerative Torque Limit	Unit: 1
Control mode	FOCPG TQCPG	Factory Setting: 200
	Settings	0 to 500%

 The motor rated torque is 100%. The settings for Pr.07-32 to Pr.07-35 will compare with Pr.03-00=7, 8, 9, 10. The minimum of the comparison result will be torque limit as shown in the following figure.

 According to the formula of motor rated torque: $T(N.M) = \frac{P(\omega)}{W(rad/s)}$, where $P(\omega)$ is

$$\text{Pr.05-02 and } W(\text{rad/s}) \text{ is Pr.05-03. } \frac{RPM}{60 \times 2\pi} = \text{rad/s}$$

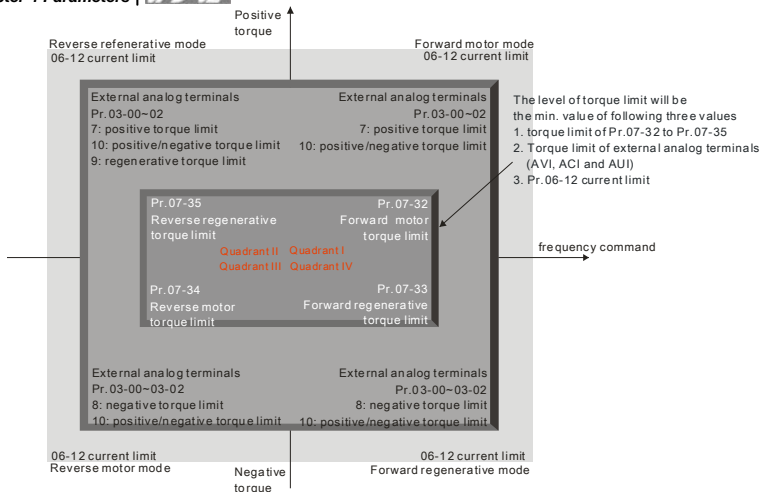

07-36 Emergency Stop (EF) & Forced Stop Selection

Control mode	VF	VFPG	SVC	FOCPG	TQCPG	Factory Setting: 0
Settings			0 Coast stop			
			1 By deceleration Time 1			
			2 By deceleration Time 2			
			3 By deceleration Time 3			
			4 By deceleration Time 4			
			5 System Deceleration			
			6 Automatic Deceleration			

When the multi-function input terminal is set to 10 or 18 and it is ON, the AC motor drive will be operated by Pr.07-36.

Group 8 High-function PID Parameters

08-00		Input Terminal for PID Feedback				Factory Setting: 0
Control mode	VF	VFPG	SVC	FOCPG		
	Settings	0	No function			
		1	Negative PID feedback from external terminal AVI (Pr.03-00)			
		2	Negative PID feedback from PG card (Pr.10-15, skip direction)			
		3	Negative PID feedback from PG card (Pr.10-15)			
		4	Positive PID feedback from external terminal AVI (Pr.03-00)			
		5	Positive PID feedback from PG card (Pr.10-15, skip direction)			
		6	Positive PID feedback from PG card (Pr.10-15)			

 **Negative feedback means: +target value – feedback. It is used for the detection value will be increased by increasing the output frequency.**

 **Positive feedback means: -target value + feedback. It is used for the detection value will be decreased by increasing the output frequency.**

08-01		Proportional Gain (P)				Unit: 0.1
Control mode	VF	VFPG	SVC	FOCPG	Factory Setting: 80.0	
	Settings	0.0 to 500.0%				

 **This parameter determinates the gain of the feedback loop. If the gain is large, the response will be strong and immediate (if the gain is too large, vibration may occur). If the gain is small, the response will weak and slow.**

08-02		Integral Gain (I)				Unit: 0.01
Control mode	VF	VFPG	SVC	FOCPG	Factory Setting: 1.00	
	Settings	0.00 to 100.00 sec				

 **This parameter determines the speed of response for the PID feedback loop. If the integral time is long, the response will be slow. If the integral time is short, the response will be quick. Be careful not to set(I) too small, since a rapid response may cause oscillation in the PID loop.**

 **If the integral time is set as 0.00, Pr.08-02 will be disabled.**

08-03	↗ Derivative Control (D)				Unit: 0.01
Control mode	VF	VFPG	SVC	FOCPG	Factory Setting: 0.00
Settings	0.00 to 1.00 sec				

 This parameter determines the damping effect for the PID feedback loop. If the differential time is long, any oscillation will quickly subside. If the differential time is short, the oscillation will subside slowly.

08-04	↗ Upper limit for Integral Control				Unit: 0.1
Control mode	VF	VFPG	SVC	FOCPG	Factory Setting: 100.0
Settings	0.0 to 100.0%				

 This parameter defines an upper bound or limit for the integral gain (I) and therefore limits the Master Frequency.

The formula is: Integral upper bound = Maximum Output Frequency (Pr.01-00) x (Pr.08-04).

08-05	↗ PID Output Frequency Limit				Unit: 0.1
Control mode	VF	VFPG	SVC	FOCPG	Factory Setting: 100.0
Settings	0.0 to 110.0%				

 This parameter defines the percentage of output frequency limit during the PID control. The formula is Output Frequency Limit = Maximum Output Frequency (Pr.01-00) X Pr.08-05 %. This parameter will limit the Maximum Output Frequency.

08-06	↗ PID Offset				Unit: 0.1
Control mode	VF	VFPG	SVC	FOCPG	Factory Setting: 0.0
Settings	-100.0 to 100.0%				

08-07	↗ PID Delay Time				Unit: 0.1
Control mode	VF	VFPG	SVC	FOCPG	Factory Setting: 0.0
Settings	0.0 to 2.5 sec				

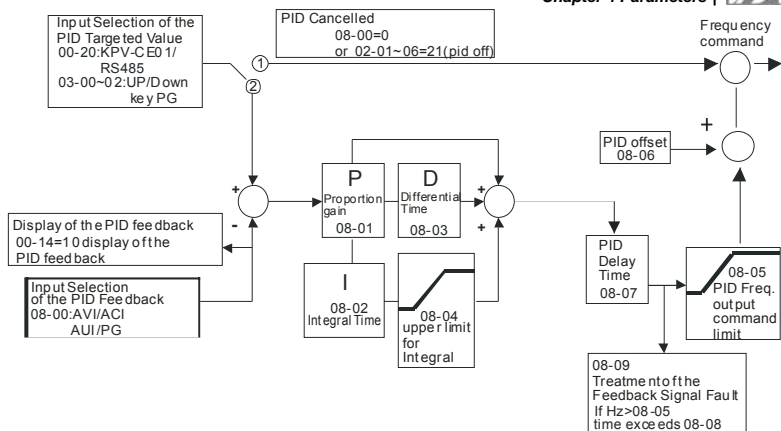

- PI Control:** controlled by the P action only, and thus, the deviation cannot be eliminated entirely. To eliminate residual deviations, the P + I control will generally be utilized. And when the PI control is utilized, it could eliminate the deviation incurred by the targeted value changes and the constant external interferences. However, if the I action is excessively powerful, it will delay the responding toward the swift variation. The P action could be used solely on the loading system that possesses the integral components.
- PD Control:** when deviation occurred, the system will immediately generate some operation load that is greater than the load generated single handedly by the D action to restrain the increment of the deviation. If the deviation is small, the effectiveness of the P action will be decreasing as well. The control objects include occasions with integral component loads, which are controlled by the P action only, and sometimes, if the integral component is functioning, the whole system will be vibrating. On such occasions, in order to make the P action's vibration subsiding and the system stabilizing, the PD control could be utilized. In other words, this control is good for use with loadings with no brake functions over the processes.
- PID Control:** Utilize the I action to eliminate the deviation and the D action to restrain the vibration, thereafter, combine with the P action to construct the PID control. Use of the PID method could obtain a control process with no deviations, high accuracies and a stable system.

08-08	↗ Feedback Signal Detection Time				Unit: 0.1
Control mode	VF	VFPG	SVC	FOCPG	Factory Setting: 0.0
Settings	0.0 to 3600.0 sec				

 This parameter is only valid when the feedback signal is ACI.

 This parameter defines the time during which the PID feedback must be abnormal before a warning is given. It also can be modified according to the system feedback signal time.

 If this parameter is set to 0.0, the system would not detect any abnormality signal.

08-09	Feedback Fault Treatment				Factory Setting: 0
Control mode	VF	VFPG	SVC	FOCPG	Factory Setting: 0
Settings	0	Warn and keep operating			
	1	Warn and RAMP to stop			
	2	Warn and COAST to stop			
	3	Warn and keep at last frequency			

 This parameter is only valid when the feedback signal is ACI.

 AC motor drive acts when the feedback signals (analog PID feedback or PG (encoder) feedback) are abnormal.

08-10	↗ Sleep Frequency				Unit: 0.01
Control mode	VF	VFPG	SVC	FOCPG	Factory Setting: 0.00
Settings	0.00 to 600.00Hz				

08-11	↗ Wake-up Frequency				Unit: 0.01
Control mode	VF	VFPG	SVC	FOCPG	Factory Setting: 0.00
Settings	0.00 to 600.00Hz				

08-12	↗ Sleep Time				Unit: 0.1
Control mode	VF	VFPG	SVC	FOCPG	Factory Setting: 0.0
Settings	0.0 to 6000.0sec				

 These parameters determine sleep functions of the AC drive. If the command frequency falls below the sleep frequency, for the specified time in Pr. 08-12, then the drive will

shut off the output and wait until the command frequency rises above Pr. 08-11. Please see the below diagram.

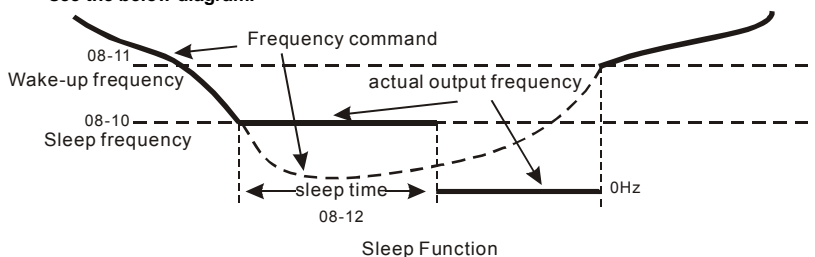

08-13	✓ PID Deviation Level					Unit: 0.1
Control mode	VF	VFPG	SVC	FOCPG	Factory Setting: 10.0	
	Settings	1.0 to 50.0%				
08-14	✓ PID Deviation Time					Unit: 0.1
Control mode	VF	VFPG	SVC	FOCPG	Factory Setting: 5.0	
	Settings	0.1 to 300.0 sec				
08-15	✓ Filter Time for PID Feedback					Unit: 0.1
Control mode	VF	VFPG	SVC	FOCPG	Factory Setting: 5.0	
	Settings	0.1 to 300.0 sec				
08-16	Reserved					
08-17	Reserved					
08-18	Reserved					
08-19	Reserved					
08-20	Reserved					

08-21 Tension Control Selection

Settings 0 to 4

Factory Setting: 0

Settings	Control Mode				
	VF	VFPG	SVC	FOCPG	TQCPG
0: Disable					
1: Tension closed-loop, speed mode	○	○	○	○	
2: Line speed closed-loop, speed mode	○	○	○	○	
3: Tension close-loop, torque mode					○
4: Tension open-loop, torque mode					○

 **1:Tension closed-loop, speed mode**
The calculation of the master frequency of the tension control

$$\text{Master frequency (Hz)} = \frac{V}{\pi D} * \frac{A}{B}$$

V: line speed m/min

D: Reel diameter m

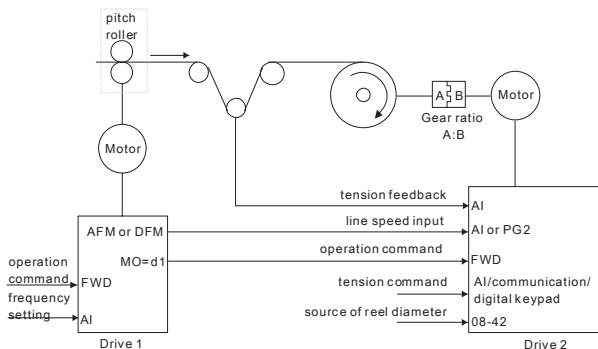
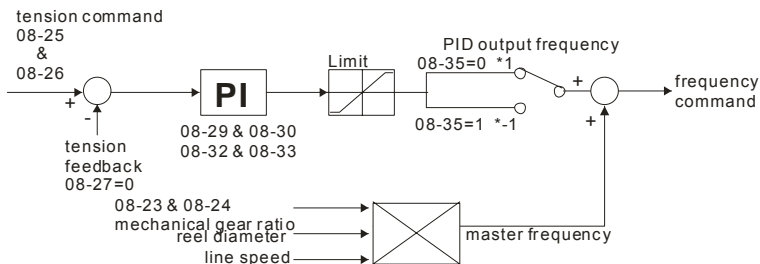
 $\frac{A}{B}$: Mechanical gear ratio

2: Line speed closed-loop, speed mode

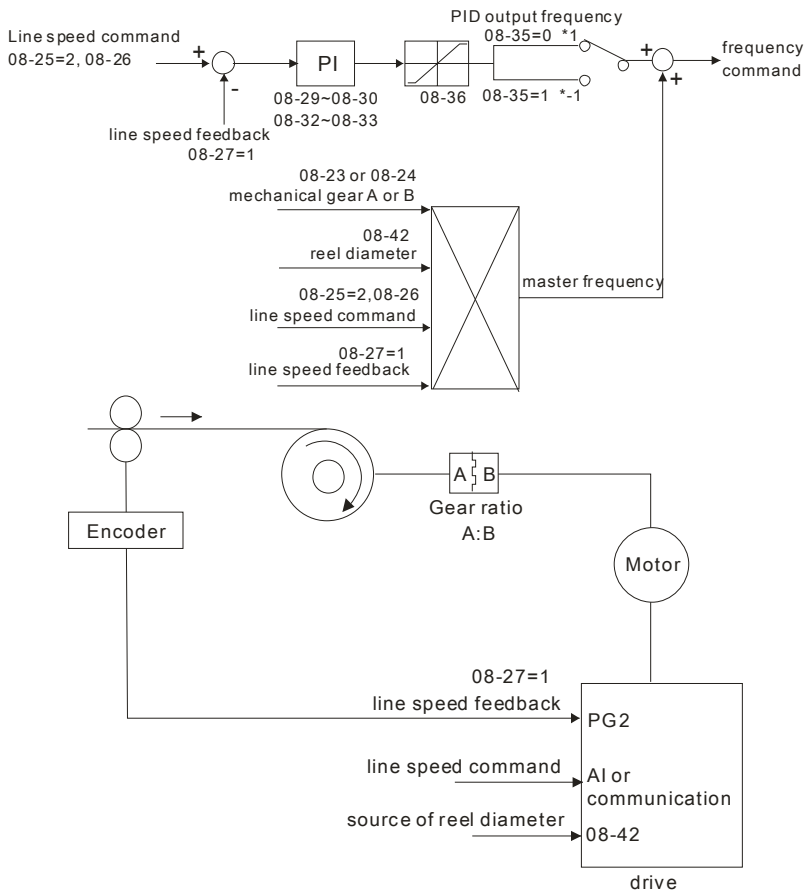

4: Tension open-loop, torque mode

$$\text{Torque (N-M)} = \frac{F * D}{2}$$

F: tension (N)

D: reel diameter (m)

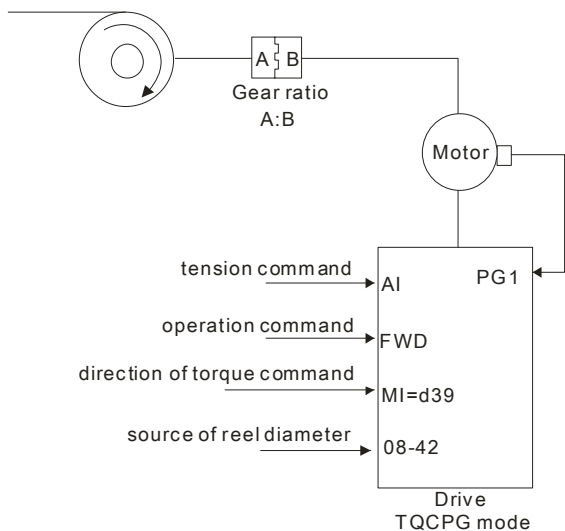
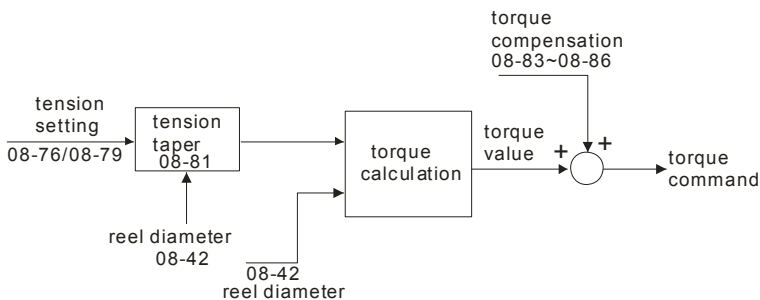

3: Tension closed-loop, torque mode

$$\text{Torque (N-M)} = \frac{F * D}{2}$$

F: tension (N)

D: reel diameter (m)

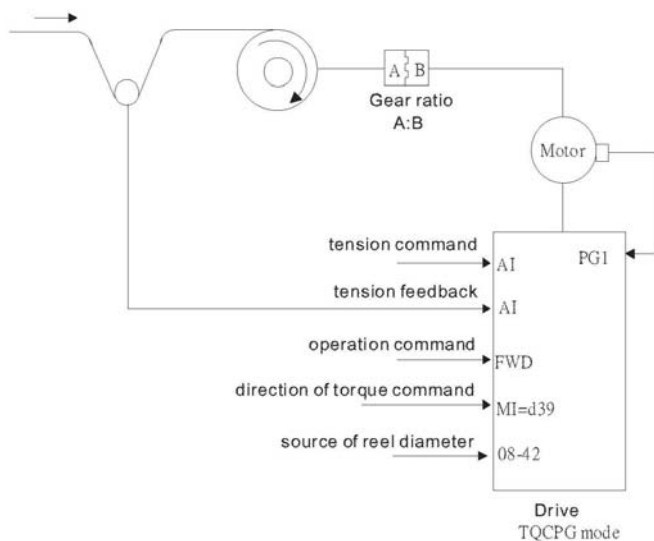
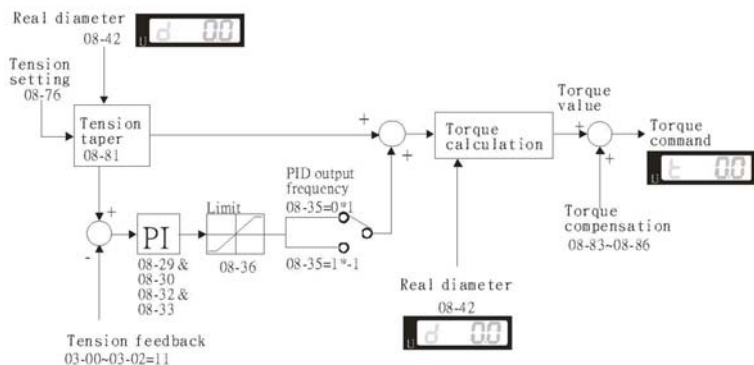



08-22 Wind Mode

Control mode	VF	VFPG	SVC	FOCPG	TQCPG	Factory Setting: 0
Settings		0		Rewind		
		1		Unwind		

When it is set to 0, the reel diameter (D) will increase. When it is set to 1, the reel diameter will decrease as shown in the following diagram.



08-23 Mechanical Gear A at Reel Unit: 1

08-24 Mechanical Gear B at Motor Unit: 1

Control mode	VF	VFPG	SVC	FOCPG	TQCPG	Factory Setting: 100
Settings			1 to 65535			

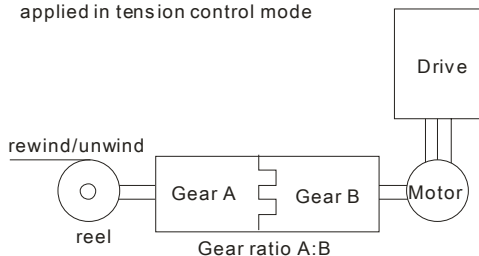

Pr.08-23 and Pr.08-24 are only for tension control mode.
applied in tension control mode



08-25 Source of the Tension Command/Line Speed

Control mode	VF	VFPG	SVC	FOCPG	TQCPG	Factory Setting: 0
Settings		0		Parameter setting (Pr.08-26)		
		1		RS-485 communication setting (Pr.08-26)		
		2		Analog input (Pr. 03-00~03-02=14 PID target value of tension, 03-00~03-02=12 line speed)		

When it is set to 0, it can adjust Pr.08-26 setting (PID Target Value of Tension/Line Speed) by the digital keypad.

-  When it is set to 1, it can adjust Pr.08-26 setting (PID Target Value of Tension/Line Speed) by the communication
-  When it is set to 2, the source of tension command is the external analog input terminals (Pr.03-00~03-02). When Pr.03-00~03-02 is set to 14 (PID target value of tension), Pr.08-26 will display the PID target value of tension.
-  When it is set to 2, the source of tension command is the external analog input terminals (Pr.03-00~03-02). When Pr.03-00~03-02 is set to 12 (line speed), Pr.08-26 will display the PID target value of line speed.

08-26	✓ PID Target Value of Tension/Line Speed				Unit: 0.1
Control mode	VF	VFPG	SVC	FOCPG	Factory Setting: 50.0
	Settings		0.0 to 100.0%		

-  The setting range 0.0 to 100.0% corresponds to tension feedback 0~10V/0~max. line speed (Pr.08-38).

 **Example:**

In tension mode, when Pr.08-21 is set to 1 (Tension closed-loop, speed mode), the setting 14 of Pr.03-00~03-02 (PID target value of tension) corresponds to tension feedback 0~10V.

In tension mode, when Pr.08-21 is set to 2 (Line speed closed-loop, speed mode), the setting 12 of Pr.03-00~03-02 (line speed) corresponds to 0~max. line speed (Pr. 08-38).

08-27	Source of Tension/Line Speed PID Feedback				Factory Setting: 0
Control mode	VF	VFPG	SVC	FOCPG	
	Settings		0	Analog input (Pr. 03-00~03-02 is set to 11 PID feedback of tension)	
		1	Pulse input (Pr.08-40)		

08-28	Auto-tuning Tension PID				Factory Setting: 0
Control mode	VF	VFPG	SVC	FOCPG	
	Settings		0	Disable	
			1	Reel diameter (08-29~08-30 corresponds to 08-44, 08-32~08-33 corresponds to 08-43)	
		2	Frequency (08-29~08-30 corresponds to 01-07, 08-32~08-33 corresponds to 01-00)		

-  When Pr.08-28 is set to 1:

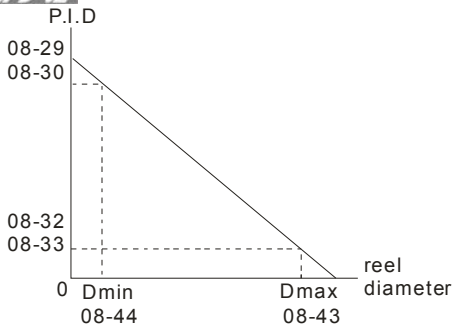

 When Pr.08-28 is set to 2:

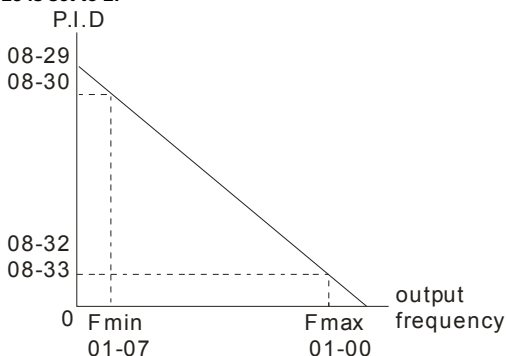

08-29  Proportional Gain 1 of Tension PID P

Unit: 0.1

Control mode VF VFPG SVC FOCPG

Factory Setting: 50.0

Settings 0.0 to 1000.0

08-30  Integral Time of Tension PID I

Unit: 0.01

Control mode VF VFPG SVC FOCPG

Factory Setting: 1.00

Settings 0.00 to 500.00 sec

08-31 Reserved

08-32  Proportional Gain 2 of Tension PID P

Unit: 0.1

Control mode VF VFPG SVC FOCPG

Factory Setting: 50.0

Settings 0.0 to 1000.0

08-33	Integral Time 2 of Tension PID I					Unit: 0.01
Control mode	VF	VFPG	SVC	FOCPG		Factory Setting: 1.00
	Settings		0.00 to 500.00 sec			

08-34	Reserved				
--------------	----------	--	--	--	--

08-35	PID Output Status					
Control mode	VF	VFPG	SVC	FOCPG	TQCPG	Factory Setting: 0
	Settings		0	Positive output		
			1	Negative output		

 **Please select the applicable method by the different requirements from the following table.**





Tension feedback

	0 ~ 100% loose	0 ~ 100% tight
Rewind	positive output	negative output
Unwind	negative output	positive output

08-36	Tension/Line Speed PID Output Limit					Unit: 0.01
Control mode	VF	VFPG	SVC	FOCPG		Factory Setting: 20.00
	Settings		0 to 100.00%			

 **Output limit range=Pr.08-36 * Pr.01-00.**

08-37	Source of Line Speed Input Command					
Control mode	VF	VFPG	SVC	FOCPG	TQCPG	Factory Setting: 0
	Settings		0	Disable		
			1	Analog input (Pr. 03-00~03-02 is set to 12 line speed)		
			2	RS-485 communication setting (Pr.08-41)		
			3	Pulse input (Pr.08-40)		
			4	DFM-DCM pulse input (Pr.02-18)		

-  When it is set to 1, 3 or 4, the current line speed will be saved into Pr.08-41 via analog and pulse command. When it is set to 2, it can change the setting of Pr.08-41 (current line speed) via communication.
-  When it is set to 3 or 4, pulse signal needs to be connected to PG2 of the PG card and then set the PG type by Pr.10-15.
-  When it is set to 3, it needs to use with Pr.08-40.
-  When it is set to 4, Pr.02-18 setting needs to be set to the DFM output value of previous driver as shown in the following before setting Pr.08-38.

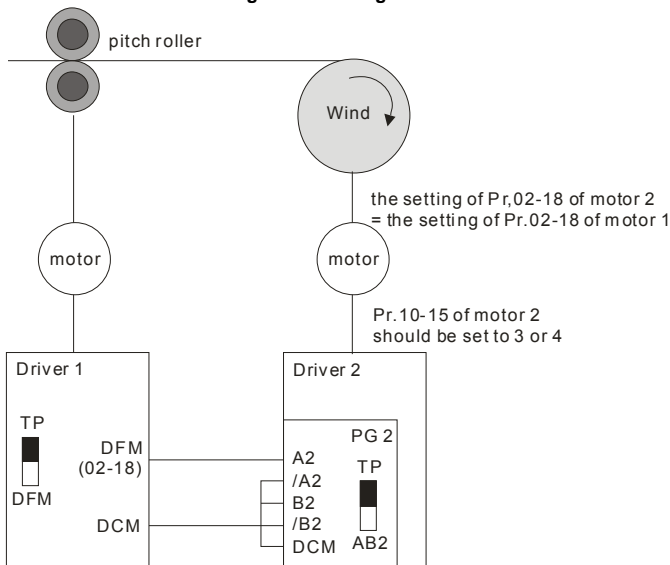

**08-38** Max. Line Speed

Unit: 0.1

Control mode	VF	VFPG	SVC	FOCPG	TQCPG
--------------	----	------	-----	-------	-------

Factory Setting: 1000.0

Settings	0.0 to 3000.0 m/min				
----------	---------------------	--	--	--	--

-  In tension closed-loop and open-loop mode, the max. line speed is the reel line speed of the pitch roller that corresponds to the max. frequency.
-  In closed-loop of line speed, setting by the mechanism requirement.

08-39	Min. Line Speed	Unit: 0.1
--------------	-----------------	-----------

Control mode	VF	VFPG	SVC	FOCPG	TQCPG	
						Factory Setting: 0.0
Settings		0.0 to 3000.0 m/min				

-  **When the line speed setting is lower than PR.08-39, the drive will stop calculating the reel diameter.**



08-40	Pulse Number for Each Meter	Unit: 0.1
--------------	-----------------------------	-----------

Control mode	VF	VFPG	SVC	FOCPG	TQCPG	
						Factory Setting: 0.0
Settings		0.0 to 6000.0 pulse/m				

-  **When Pr.08-37 is set to 3, it needs to be used with this parameter.**



08-41	Current Line Speed	Unit: 0.1
--------------	--------------------	-----------

Control mode	VF	VFPG	SVC	FOCPG	TQCPG	
						Factory Setting: 0.0
Settings		0.0 to 3000.0 m/min				

-  **The display range of this parameter is according to Pr.08-38 and Pr.08-39.**
-  **When Pr.08-37 is set to 1, 3, or 4, the current line speed will be saved into Pr.08-41 via analog and pulse command. At this time, Pr.08-41 will be read only.**
-  **When Pr.08-37 is set to 2, the setting of Pr.08-41(current line speed) can be changed by communication.**

08-42	Source of Reel Diameter	
--------------	-------------------------	--

Control mode	VF	VFPG	SVC	FOCPG	TQCPG	
						Factory Setting: 0
Settings		0	Calculated by line speed			
		1	Calculated by integrating thickness (encoder is on reel shaft)(Pr.08-49~51, Pr.10-15)			
		2	Calculated by integrating thickness (encoder is on motor)(Pr.08-23~08-24, 08-50~08-51, 10-00~10-01)			
		3	Calculated by analog input (Pr.03-00~03-02 is set to 13)			

-  **When it is set to 1 or 2, it needs to be used with PG card.**
-  **When it is set to 1, the reel diameter can be got from the encoder on the reel shaft. At this time, the pulse signal needs to be connected to the PG2 of PG card and get the reel diameter from the settings of Pr.10-15, Pr.08-49, Pr.08-50 and Pr.08-51.**
-  **When it is set to 2, the reel diameter can be calculated from the motor encoder and gear ratio. At this time, the pulse signal should be connected to the PG1 of the PG card and**

get the reel diameter from the settings of Pr.08-23, Pr.08-24, Pr.10-01, Pr.10-00, Pr.08-50 and Pr.08-51.

When it is set to 3, the reel diameter can be calculated by analog input (Pr.03-00-03-02 is set to 13) and the corresponding value of 10V is Pr.08-43.

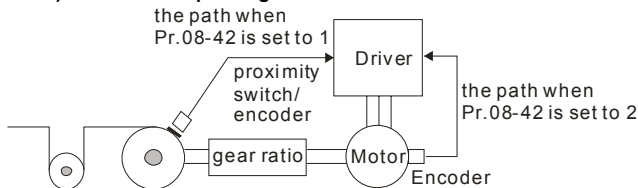

Definition of reel diameter

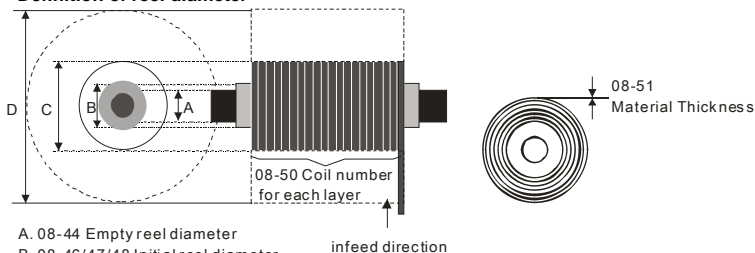

- A. 08-44 Empty reel diameter
- B. 08-46/47/48 Initial reel diameter
- C. 08-54 Current reel diameter
- D. 08-43 Max. reel diameter

08-43	↗ Max. Reel Diameter					Unit: 0.1
Control mode	VF	VFPG	SVC	FOCPG	TQCPG	Factory Setting: 6000.0
Settings	1.0 to 6000.0mm					

08-44	↗ Empty Reel Diameter					Unit: 0.1
Control mode	VF	VFPG	SVC	FOCPG	TQCPG	Factory Setting: 1.0
Settings	1 to 6000.0mm					

08-45	Source of Reel Diameter					Factory Setting: 0
Control mode	VF	VFPG	SVC	FOCPG	TQCPG	
Settings	0	RS-485 communication setting (Pr.08-46)				
	1	Analog input (Pr.03-00-Pr.03-02 is set to 13)				

When it is set to 1, the corresponding value of 10V is Pr.08-43.

08-46 / Initial Reel Diameter Unit: 0.1

Factory Setting: 1.0

Control mode VF VFPG SVC FOCPG TQCPG



Settings 0.0 to 6000.0mm

 **When Pr.08-45 is set to 1, Pr.08-46 will be read-only.****08-47** Initial Reel Diameter 1 Unit: 0.1**08-48** Initial Reel Diameter 2 Unit: 0.1

Factory Setting: 1.0

Control mode VF VFPG SVC FOCPG TQCPG

Settings 0.0 to 6000.0mm

 **Pr.08-46 needs to be used by setting 44~46 to Pr.02-01~02-06, Pr.02-23~Pr.02-30.** **When you need to have many types of reel diameter, please set Pr.08-45 to 0 (set by communication). For example: Pr.08-46 setting can be changed by inputting the digital keypad, HMI page plan or text panel(PLC product: TP series) via communication.** **When the drive is at stop and it is in tension control mode, it needs to set 3-step initial reel diameter (Pr.08-46~48) by the digital status of multi-function input terminal setting 45 and 46 before using terminal 44 as shown in the following table.**

MI=46	MI=45	MI=44
OFF	OFF	ON: it will write Pr.08-46 into Pr.54
OFF	ON	ON: it will write Pr.08-47 into Pr.08-54
ON	OFF	ON: it will write Pr.08-48 into Pr.08-54
ON	ON	ON: it will reset Pr.08-54 to the factory setting

**08-49** Number of Pulse Per Revolution Unit: 1

Factory Setting: 1

Control mode VF VFPG SVC FOCPG TQCPG

Settings 1 to 10000ppr

 **When Pr.08-42 is set to 1, it needs to be used with this parameter. This parameter is the number of pulse per revolution that a reel rotates.****08-50** Coil Number for Each Layer Unit: 1

Factory Setting: 1

Control mode VF VFPG SVC FOCPG TQCPG

Settings 1 to 10000

 **It is used to set the coil number that a reel needs to increase a layer.**

08-51	Material Thickness					Unit: 0.001
Control mode	VF	VFPF	SVC	FOCPG	TQCPG	Factory Setting: 1.000
Settings	0.001 to 60.000mm					

 **It is used to set the thickness of the material.**

08-52	Filter Time of Reel Diameter					Unit: 0.01
Control mode	VF	VFPF	SVC	FOCPG	TQCPG	Factory Setting: 1.00
Settings	0.00 to 100.00 sec					

 **This parameter can be used to improve unstable of the source of reel diameter(Pr.08-42).**

08-53	Auto Compensation of Reel Diameter					Factory Setting: 0
Control mode	VF	VFPF	SVC	FOCPG	TQCPG	
Settings	0	Disable				
	1	Enable				

 **This parameter is only valid when Pr.08-21 is set to 1 and Pr.08-37 is not set to 0. It can use this parameter for auto compensation of reel diameter when the mechanical gear ratio or line speed can't be accurate.**

08-54	Current Reel Diameter					Unit: 0.1
Control mode	VF	VFPF	SVC	FOCPG	TQCPG	Factory Setting: 1.0
Settings	1.0 to 6000.0 mm					

 **When the AC motor drive is not at STOP, this parameter is read-only.**

08-55	Smart Start Function					Factory Setting: 0
Control mode	VF	VFPF	SVC	FOCPG		
Settings	0	Disable				
	1	Enable				
	2	In unwind mode, rewind in reverse direction				

08-56	Switch Level for Smart Start and PID Function					Unit: 1
Control mode	VF	VFPF	SVC	FOCPG		Factory Setting: 15.0
Settings	0.0~100.0% (according to Pr.08-26)					

-  **Example:** Assume that the tension feedback 0~100% corresponds to loose tension to tight tension, Pr.08-26=50% and Pr.08-56=10%, the smart start range will be from 0~40%.

08-57	Frequency for Smart Start				Unit: 1
Control mode	VF	VFPG	SVC	FOCPG	Factory Setting: 2.00
	Settings	0.00~600.00Hz			

08-58	✓ Accel. Time for Smart Start				Unit: 0.01
Control mode	VF	VFPG	SVC	FOCPG	Factory Setting: 3.00
	Settings	0.01~600.00 sec			

-  Pr.08-55~08-58 are only valid when Pr.08-21 is set to 1.

-  Pr.08-58 is only valid when there is no source of line speed.

-  When start-up, it can set Pr.08-55 to 1 to prevent too long time for stable the dancer (under loose material or out of Pr.08-56 setting).

Example: The PID control is only valid when setting Pr.08-57 and Pr.08-58 to make the tension feedback reaches Pr.08-56 setting.

-  In unwind mode, when Pr.08-55 is set to 2, it allows to operate the motor in opposite direction to tight the material automatically.

08-59	Broken Belt Detection				
Control mode	VF	VFPG	SVC	FOCPG	Factory Setting: 0
	Settings	0	Disable		
		1	Enable		

08-60	Min. Line Speed of Broken Belt Detection				Unit: 0.1
Control mode	VF	VFPG	SVC	FOCPG	Factory Setting: 0.0
	Settings	0.0~3000.0 m/min			

08-61	Allowance Difference of Reel Diameter of Broken Belt Detection				Unit: 0.1
Control mode	VF	VFPG	SVC	FOCPG	Factory Setting: 100.0
	Settings	1.0~6000.0 mm			

08-62	Detection Time of Broken Belt				Unit: 0.1
Control mode	VF	VFPG	SVC	FOCPG	Factory Setting: 1.00
Settings	0.00~100.00 sec				

 Pr.08-59 is only valid when Pr.08-39 is not set to 0 and Pr.08-42 is set to 0.

 When the broken belt detection is enabled, line speed is higher than Pr.08-60, allowance difference of reel diameter of broken belt detection exceeds Pr.08-61 and detection time of broken belt exceeds Pr.08-62, the broken belt occurs. When the broken belt occurs, it will display “bEb” with free running. It can be used with the multi-function output terminal setting 46 for broken belt detection.

08-63	Allowance Error Level of Tension/Line Speed PID Feedback				Unit: 1
Control mode	VF	VFPG	SVC	FOCPG	Factory Setting: 100
Settings	0~100%				

 The corresponding value for the 100% of tension feedback is 10V.

08-64	Allowance Error Detection Time of Tension/Line Speed PID Feedback				Unit: 0.1
Control mode	VF	VFPG	SVC	FOCPG	Factory Setting: 0.5
Settings	0.0~10.0 sec				

08-65	Error Treatment of Tension/Line Speed PID Feedback				Factory Setting: 0
Control mode	VF	VFPG	SVC	FOCPG	
Settings	0	Warn and keep operation			
	1	Warn and coast to stop			
	2	Warn and ramp to stop			

 When the error of tension PID target value and tension PID feedback exceeds Pr.08-63 and the allowance error detection time of tension PID exceeds Pr.08-64, tension PID feedback error occurs. Refer to Pr.08-65 for error treatment of tension PID feedback. It will display “tdEv” at this moment.

08-66	Upper Limit of Tension PID Feedback					Unit: 0.1
Control mode	VF	VFPG	SVC	FOCPG	TQCPG	Factory Setting: 100.0
	Settings	0.0~100.0%				

08-67	Lower Limit of Tension PID Feedback					Unit: 0.1
Control mode	VF	VFPG	SVC	FOCPG	TQCPG	Factory Setting: 0.0
	Settings	0.0~100.0%				

 **It is valid when Pr.08-21 is set to 1.**

08-68	Reserved				
--------------	----------	--	--	--	--

08-69	DFM Selection					Factory Setting: 0
Control mode	VF	VFPG	SVC	FOCPG	TQCPG	
	Settings	0	Output frequency			
		1	Frequency command			

08-70	✓ Low-pass Filter Time of Line Speed					Unit: 0.01
Control mode	VF	VFPG	SVC	FOCPG	TQCPG	Factory Setting: 0.00
	Settings	0.00~100.00 sec				

 **It is used to suppress the oscillation of line speed.**

08-71	Reserved				
08-75					

08-76	Source of Tension Setting					Factory Setting: 0
Control mode	TQCPG					
	Settings	0	Communication RS-485 (Pr.08-78)			
		1	Analog input (Pr. 03-00~03-02 is set to 15 tension setting) (Pr.08-78)			

 **Pr.08-76~08-86 are valid when Pr.08-21 is set to 4.**

 **When Pr.08-76 is set to 0, Pr.08-78 setting can be changed by inputting the digital keypad, HMI page plan or text panel(PLC product: TP series) via communication.**

 **When Pr.08-76 is set to 1 and one of Pr.03-00~03-02 is set to 15, Pr.08-78 will display the tension setting.**

08-77	Max. Tension	Unit: 1
Control mode	TQCPG	Factory Setting: 0
Settings	0 ~30000 N	

08-78	↗ Tension Setting	Unit: 1
Control mode	TQCPG	Factory Setting: 0
Settings	0 ~30000 N	

 **Pr.08-78 will be read-only when Pr.08-76 is set to 1. The analog input 10V corresponds to Pr.08-77.**

08-79	Source of Zero-speed Tension Setting	
Control mode	TQCPG	Factory Setting: 0
Settings	0 Disable	
	1 Communication RS-485 (Pr.08-80)	
	2 Analog input (Pr. 03-00~03-02 is set to 16 zero-speed tension) (Pr.08-80)	

 **When Pr.08-79 is set to 1, Pr.08-80 setting can be changed by inputting the digital keypad, HMI page plan, text panel (PLC product: TP series) via communication.**

 **When Pr.08-79 is set to 2 and one of Pr. 03-00~03-02=16, Pr.08-80 only displays tension setting.**

08-80	↗ Setting of Zero-speed Tension	Unit: 1
Control mode	TQCPG	Factory Setting: 0
Settings	0 ~30000 N	

 **Pr.08-80 is read-only when Pr.08-79 is set to 2. The input analog 10V corresponds to Pr.08-77.**

08-81	Source of Tension Taper	
Control mode	TQCPG	Factory Setting: 0
Settings	0 Communication RS-485 (Pr.08-82)	
	1 Analog input (Pr. 03-00~03-02 is set to 17 tension taper) (Pr.08-82)	

Control
mode

TQCPG

Settings 0~100%

- 📖 When Pr.08-81 is set to 0, Pr.08-82 setting can be changed by inputting the digital keypad, HMI page plan, text panel (PLC product: TP series) via communication.
- 📖 When Pr.08-81 is set to 1 and one of Pr.03-00~03-02 is set to 17, Pr.08-82 is used to display the tension taper only.
- 📖 During the rewind process, the tension setting should be decreased by the increased reel to rewind the material successfully.

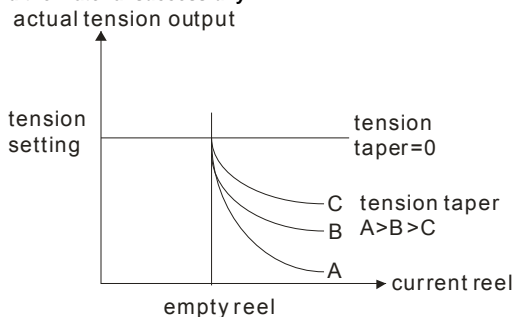

- 📖 The reel control is shown as follows.

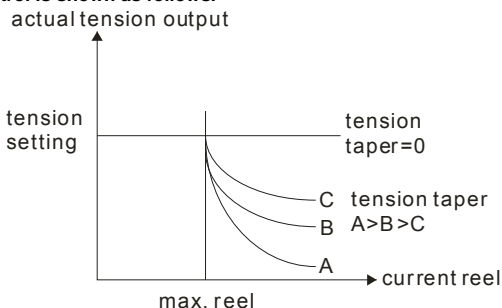

08-83  Friction Compensation

Unit: 1

Control
mode

TQCPG

Factory Setting: 0.0

Settings 0.0~100.0%

 It is used for the compensation of dynamic friction and 100% corresponds to the motor rated torque.

 The compensation coefficient of the friction torque can be got from the inertia estimation in the speed mode. Users can adjust by the requirement.

08-84  Compensation Coefficient of Material Inertial

Unit: 1

Control
mode

TQCPG

Factory Setting: 0

Settings 0~30000

 Compensation coefficient of material inertia=material density*material width. Unit for density is kg/m³ and for width is m. The material inertia of the reel will be changed by the reel.

08-85  Torque Feed Forward Gain

Unit: 0.1

Control
mode

TQCPG

Factory Setting: 50.0

Settings 0.0~100.0%

08-86  Low Pass Filter Time of Torque Feed Forward

Unit: 0.01

Control
mode

TQCPG

Factory Setting: 5.00

Settings 0.00~100.00

 Pr.08-85~08-86 are used to adjust the torque that needed by the mechanical rotation inertia during acceleration/deceleration.

08-87

| Reserved

08-99

Group 9: Communication Parameters

There is a built-in RS-485 serial interface, marked RJ-11 near to the control terminals. The pins are defined below:

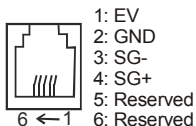

Each VFD-VE AC drive has a pre-assigned communication address specified by Pr.09-00. The RS485 master then controls each AC motor drive according to its communication address.

09-00	Communication Address					Factory Setting: 1
Control mode	VF	VFPG	SVC	FOCPG	TQCPG	
Settings	1 to 254					

 **If the AC motor drive is controlled by RS-485 serial communication, the communication address for this drive must be set via this parameter. And the communication address for each AC motor drive must be different and unique.**

09-01	COM1 Transmission Speed					Factory Setting: 9.6
Control mode	VF	VFPG	SVC	FOCPG	TQCPG	
Settings	4.8 to 115.2kbps					

 **This parameter is used to set the transmission speed between the RS485 master (PLC, PC, etc.) and AC motor drive.**

09-02	COM1 Transmission Fault Treatment					Factory Setting: 3
Control mode	VF	VFPG	SVC	FOCPG	TQCPG	
Settings	0	Warn and keep operating				
	1	Warn and RAMP to stop				
	2	Warn and COAST to stop				
	3	No warning and keep operating				

 **This parameter is set to how to react if transmission errors occur.**

09-03	COM1 Time-out Detection					Unit: 0.1
Control mode	VF	VFPG	SVC	FOCPG	TQCPG	Factory Setting: 0.0
Settings	0.0 ~ 100.0 sec (0.0 disable)					

- If Pr.09-03 is not set to 0.0, Pr.09-02=0~2, and there is no communication on the bus during the Time Out detection period (set by Pr.09-03), “cE10” will be shown on the keypad.

09-04 COM1 Communication Protocol

Control mode	VF	VFPG	SVC	FOCPG	TQCPG	Factory Setting: 1
Settings	0					Modbus ASCII mode, protocol <7,N,1>
	1					Modbus ASCII mode, protocol <7,N,2>
	2					Modbus ASCII mode, protocol <7,E,1>
	3					Modbus ASCII mode, protocol <7,O,1>
	4					Modbus ASCII mode, protocol <7,E,2>
	5					Modbus ASCII mode, protocol <7,O,2>
	6					Modbus ASCII mode, protocol <8,N,1>
	7					Modbus ASCII mode, protocol <8,N,2>
	8					Modbus ASCII mode, protocol <8,E,1>
	9					Modbus ASCII mode, protocol <8,O,1>
	10					Modbus ASCII mode, protocol <8,E,2>
	11					Modbus ASCII mode, protocol <8,O,2>
	12					Modbus RTU mode, protocol <8,N,1>
	13					Modbus RTU mode, protocol <8,N,2>
	14					Modbus RTU mode, protocol <8,E,1>
	15					Modbus RTU mode, protocol <8,O,1>
	16					Modbus RTU mode, protocol <8,E,2>
	17					Modbus RTU mode, protocol <8,O,2>

1. Control by PC or PLC

- ★ A VFD-VE can be set up to communicate on Modbus networks using one of the following modes: ASCII (American Standard Code for Information Interchange) or RTU (Remote Terminal Unit). Users can select the desired mode along with the serial port communication protocol in Pr.09-04.

★ Code Description:

ASCII mode:

Each 8-bit data is the combination of two ASCII characters. For example, a 1-byte data:

64 Hex, shown as '64' in ASCII, consists of '6' (36Hex) and '4' (34Hex).

Character	'0'	'1'	'2'	'3'	'4'	'5'	'6'	'7'
ASCII code	30H	31H	32H	33H	34H	35H	36H	37H
Character	'8'	'9'	'A'	'B'	'C'	'D'	'E'	'F'
ASCII code	38H	39H	41H	42H	43H	44H	45H	46H

RTU mode:

Each 8-bit data is the combination of two 4-bit hexadecimal characters. For example, 64 Hex.

**2. Data Format**

10-bit character frame (For ASCII):

(7.N.2)

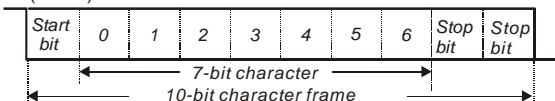

(7.E.1)

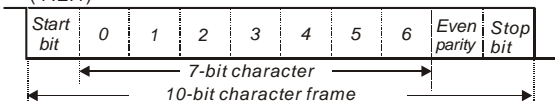

(7.O.1)

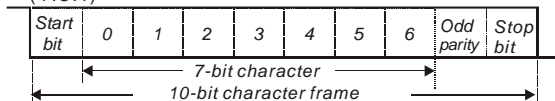

11-bit character frame (For RTU):

(8.N.2)

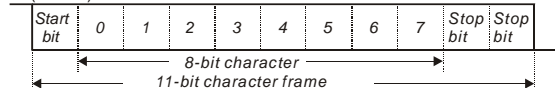

(8.E.1)

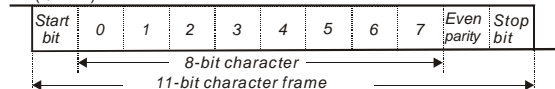

(8.O.1)

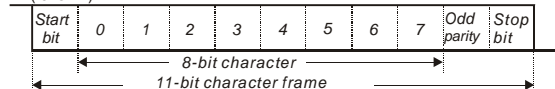
**3. Communication Protocol****3.1 Communication Data Frame:****ASCII mode:**

STX	Start character ':' (3AH)
Address Hi	Communication address:
Address Lo	8-bit address consists of 2 ASCII codes
Function Hi	Command code:
Function Lo	8-bit command consists of 2 ASCII codes
DATA (n-1) to DATA 0	Contents of data: Nx8-bit data consist of 2n ASCII codes n<=16, maximum of 32 ASCII codes

LRC CHK Hi	LRC check sum:
LRC CHK Lo	8-bit check sum consists of 2 ASCII codes
END Hi	End characters:
END Lo	END1= CR (0DH), END0= LF(0AH)

RTU mode:

START	A silent interval of more than 10 ms
Address	Communication address: 8-bit address
Function	Command code: 8-bit command
DATA (n-1) to DATA 0	Contents of data: n×8-bit data, n<=16
CRC CHK Low	CRC check sum: 16-bit check sum consists of 2 8-bit characters
CRC CHK High	
END	A silent interval of more than 10 ms

3.2 Address (Communication Address)

Valid communication addresses are in the range of 0 to 254. A communication address equal to 0, means broadcast to all AC drives (AMD). In this case, the AMD will not reply any message to the master device.

00H: broadcast to all AC drives

01H: AC drive of address 01

0FH: AC drive of address 15

10H: AC drive of address 16

⋮

FEH: AC drive of address 254

For example, communication to AMD with address 16 decimal (10H):

ASCII mode: Address='1','0' => '1'=31H, '0'=30H

RTU mode: Address=10H

3.3 Function (Function code) and DATA (data characters)

The format of data characters depends on the function code.

03H: read data from register

06H: write single register

08H: loop detection

10H: write multiple registers

The available function codes and examples for VFD-VE are described as follows:

(1) 03H: multi read, read data from registers.

Example: reading continuous 2 data from register address 2102H, AMD address is 01H.

ASCII mode:

Command message:

STX	':'
Address	'0'
	'1'
Function	'0'
	'3'
Starting data address	'2'
	'1'
	'0'
	'2'

Response message:

STX	':'
Address	'0'
	'1'
Function	'0'
	'3'
Number of data (Count by byte)	'0'
	'4'
Content of starting address	'1'
	'7'

Command message:

Number of data (count by word)	'0'
	'0'
	'0'
LRC Check	'2'
	'D'
END	'7'
	CR
	LF

Response message:

2102H	'7'
	'0'
	'0'
Content of address 2103H	'0'
	'0'
	'0'
LRC Check	'7'
	'1'
END	CR
	LF

RTU mode:

Command message:

Address	01H
Function	03H
Starting data address	21H
	02H
Number of data (count by word)	00H
	02H
CRC CHK Low	6FH
CRC CHK High	F7H

Response message:

Address	01H
Function	03H
Number of data (count by byte)	04H
Content of address 2102H	17H
	70H
Content of address 2103H	00H
	00H
CRC CHK Low	FEH
CRC CHK High	5CH

(2) 06H: single write, write single data to register.

Example: writing data 6000(1770H) to register 0100H. AMD address is 01H.

ASCII mode:

Command message:

STX	':'
Address	'0'
	'1'
Function	'0'
	'6'
Data address	'0'
	'1'
	'0'
Data content	'0'
	'1'
	'7'
	'7'
LRC Check	'0'
	'7'
END	'1'
	CR
	LF

Response message:

STX	':'
Address	'0'
	'1'
Function	'0'
	'6'
Data address	'0'
	'1'
	'0'
Data content	'0'
	'1'
	'7'
	'7'
LRC Check	'0'
	'7'
END	'1'
	CR
	LF

RTU mode:

Command message:

Address	01H
Function	06H
Data address	01H
	00H

Response message:

Address	01H
Function	06H
Data address	01H
	00H

Data content	17H
	70H
CRC CHK Low	86H
CRC CHK High	22H

Data content	17H
	70H
CRC CHK Low	86H
CRC CHK High	22H

(3) 10H: write multiple registers (write multiple data to registers)

Example: Set the multi-step speed,

Pr.05-00=50.00 (1388H), Pr.05-01=40.00 (0FA0H). AC drive address is 01H.

ASCII Mode:

Command message:

STX	':'
Address 1	'0'
Address 0	'1'
Function 1	'1'
Function 0	'0'
Starting data address	'0'
	'5'
	'0'
	'0'
Number of data (count by word)	'0'
	'0'
	'2'
	'2'
Number of data (count by byte)	'0'
	'4'
The first data content	'1'
	'3'
	'8'
	'8'
The second data content	'0'
	'F'
	'A'
	'0'
LRC Check	'9'
	'A'
END	CR
	LF

Response message:

STX	':'
Address 1	'0'
Address 0	'1'
Function 1	'1'
Function 0	'0'
Starting data address	'0'
	'5'
	'0'
	'0'
Number of data (count by word)	'0'
	'0'
	'2'
	'2'
LRC Check	'E'
	'8'
END	CR
	LF

RTU mode:

Command message:

Address	01H
Function	10H
Starting data address	05H
address	00H
Number of data (count by word)	00H'
Number of data (count by byte)	02H
Number of data (count by byte)	04
The first data content	13H
	88H
The second data content	0FH
	A0H

Response message:

Address	01H
Function	10H
Starting data address	05H
	00H
Number of data (count by word)	00H
Number of data (count by word)	02H
CRC Check Low	41H
CRC Check High	04H

CRC Check Low	'9'
CRC Check High	'A'

3.4 Check sum

ASCII mode:

LRC (Longitudinal Redundancy Check) is calculated by summing up, module 256, the values of the bytes from ADR1 to last data character then calculating the hexadecimal representation of the 2's-complement negation of the sum.

For example, reading 1 word from address 0401H of the AC drive with address 01H.

STX	':'
Address 1	'0'
Address 0	'1'
Function 1	'0'
Function 0	'3'
Starting data address	'0'
	'4'
	'0'
	'1'
Number of data	'0'
	'0'
	'0'
	'1'
LRC Check 1	'F'
LRC Check 0	'6'
END 1	CR
END 0	LF

01H+03H+04H+01H+00H+01H=0AH, the 2's-complement negation of 0AH is **F6H**.

RTU mode:

Address	01H
Function	03H
Starting data address	21H
	02H
Number of data (count by word)	00H
	02H
CRC CHK Low	6FH
CRC CHK High	F7H

CRC (Cyclical Redundancy Check) is calculated by the following steps:

Step 1: Load a 16-bit register (called CRC register) with FFFFH.

Step 2: Exclusive OR the first 8-bit byte of the command message with the low order byte of the 16-bit CRC register, putting the result in the CRC register.

Step 3: Examine the LSB of CRC register.

Step 4: If the LSB of CRC register is 0, shift the CRC register one bit to the right with MSB zero filling, then repeat step 3. If the LSB of CRC register is 1, shift the CRC register one bit to the right with MSB zero filling, Exclusive OR the CRC register with the polynomial value A001H, then repeat step 3.

Step 5: Repeat step 3 and 4 until eight shifts have been performed. When this is done, a complete 8-bit byte will have been processed.

Step 6: Repeat step 2 to 5 for the next 8-bit byte of the command message. Continue doing this until all bytes have been processed. The final contents of the CRC register are the CRC value. When transmitting the CRC value in the message, the upper and lower bytes of the CRC value must be swapped, i.e. the lower order byte will be transmitted first.

The following is an example of CRC generation using C language. The function takes two arguments:

Unsigned char* data ← a pointer to the message buffer

Unsigned char length ← the quantity of bytes in the message buffer

The function returns the CRC value as a type of unsigned integer.

```
Unsigned int crc_chk(unsigned char* data, unsigned char length){
    int j;
    unsigned int reg_crc=0xFFFF;
    while(length--){
        reg_crc ^= *data++;
        for(j=0;j<8;j++){
            if(reg_crc & 0x01){ /* LSB(b0)=1 */
                reg_crc=(reg_crc>>1) ^ 0xA001;
            }else{
                reg_crc=reg_crc >>1;
            }
        }
    }
    return reg_crc;
}
```

3.5 Address list

The contents of available addresses are shown as below:

Content	Address	Function	
AC drive Parameters	GGnnH	GG means parameter group, nn means parameter number, for example, the address of Pr 4-01 is 0401H. Referencing to chapter 5 for the function of each parameter. When reading parameter by command code 03H, only one parameter can be read at one time.	
Command Write only	2000H	Bit 0-3	0: No function 1: Stop 2: Run 3: Jog + Run
Command Write only	2000H	Bit 4-5	00B: No function 01B: FWD 10B: REV 11B: Change direction
		Bit 6-7	00B: 1st accel/decel 01B: 2nd accel/decel 10B: 3rd accel/decel 11B: 4th accel/decel
		Bit 8-11	Represented 16 step speeds.
		Bit 12	0: No comm. multi step speed or accel/decel time 1: Comm. multi step speed or accel/decel time

Content	Address	Function		
		Bit	Description	
		Bit 13~14	00B: No function	
			01B: operated by digital keypad	
			02B: operated by Pr.00-21 setting	
		03B: change operation source		
		Bit 15	Reserved	
	2001H	Frequency command		
	2002H	Bit 0	1: EF (external fault) on	
		Bit 1	1: Reset	
		Bit 2	1: B.B. ON	
		Bit 3-15	Reserved	
Status monitor Read only	2100H	Error code: refer to Pr.06-17 to Pr.06-22		
	2119H	Bit 0	1: FWD command	
		Bit 1	1: Operation status	
		Bit 2	1: Jog command	
		Bit 3	1: REV command	
		Bit 4	1: REV command	
		Bit 8	1: Master frequency Controlled by communication interface	
		Bit 9	1: Master frequency controlled by analog signal	
		Bit 10	1: Operation command controlled by communication interface	
		Bit 11	1: Parameters have been locked	
		Bit 12	1: enable to copy parameter from keypad	
		Bit 13-15	Reserved	
		2102H	Frequency command (F)	
		2103H	Output frequency (H)	
		2104H	Output current (AXXX.X)	
		2105H	DC-BUS Voltage (UXXX.X)	
		2106H	Output voltage (EXXX.X)	
		2107H	Current step number of Multi-Step Speed Operation	
		2109H	Counter value	
		2116H	Multi-function display (Pr.00-04)	
		211AH	Setting frequency (F)	
		211BH	Max. setting frequency	
		211CH	Max. output frequency	
		2200H	Feedback Signal (XXX.XX %)	
		2203H	AVI analog input (XXX.XX %)	
		2204H	ACI analog input (XXX.XX %)	
		2205H	AUJ analog input (XXX.XX %)	
		2206H	Display temperature of IGBT (°C)	
		2207H	Display temperature of heatsink (°C)	
		2208H	Digital input status	
		2209H	Digital output status	

3.6 Exception response:

The AC motor drive is expected to return a normal response after receiving command messages from the master device. The following depicts the conditions when no normal response is replied to the master device.

The AC motor drive does not receive the messages due to a communication error; thus, the AC motor drive has no response. The master device will eventually process a timeout condition.

The AC motor drive receives the messages without a communication error, but cannot handle them. An exception response will be returned to the master device and an error message "CExx" will be displayed on the keypad of AC motor drive. The xx of "CExx" is a decimal code equal to the exception code that is described below.

In the exception response, the most significant bit of the original command code is set to 1, and an exception code which explains the condition that caused the exception is returned.

Example of an exception response of command code 06H and exception code 02H:

ASCII mode:

STX	':'
Address Low	'0'
Address High	'1'
Function Low	'8'
Function High	'6'
Exception code	'0'
	'2'
LRC CHK Low	'7'
LRC CHK High	'7'
END 1	CR
END 0	LF

RTU mode:

Address	01H
Function	86H
Exception code	02H
CRC CHK Low	C3H
CRC CHK High	A1H

The explanation of exception codes:

Exception code	Explanation
01	Illegal function code: The function code received in the command message is not available for the AC motor drive.
02	Illegal data address: The data address received in the command message is not available for the AC motor drive.
03	Illegal data value: The data value received in the command message is not available for the AC drive.
04	Slave device failure: The AC motor drive is unable to perform the requested action.
10	Communication time-out: If Pr.09-03 is not equal to 0.0, Pr.09-02=0~2, and there is no communication on the bus during the Time Out detection period (set by Pr.09-03), "cE10" will be shown on the keypad.

3.7 Communication program of PC:

The following is a simple example of how to write a communication program for Modbus ASCII mode on a PC by C language.

```
#include<stdio.h>
#include<dos.h>
#include<conio.h>
#include<process.h>
#define PORT 0x03F8 /* the address of COM1 */
/* the address offset value relative to COM1 */
```

```

#define THR 0x0000
#define RDR 0x0000
#define BRDL 0x0000
#define IER 0x0001
#define BRDH 0x0001
#define LCR 0x0003
#define MCR 0x0004
#define LSR 0x0005
#define MSR 0x0006
unsigned char rdat[60];
/* read 2 data from address 2102H of AC drive with address 1 */
unsigned char tdat[60]={' ':0,'1':1,'0':3,'2':1,'0':2,'0':0,'0':2,'D':7,'r','\n'};
void main(){
int i;
outportb(PORT+MCR,0x08);      /* interrupt enable */
outportb(PORT+IER,0x01);      /* interrupt as data in */
outportb(PORT+LCR,(inportb(PORT+LCR) | 0x80));
/* the BRDL/BRDH can be access as LCR.b7==1 */
outportb(PORT+BRDL,12);      /* set baudrate=9600, 12=115200/9600*/
outportb(PORT+BRDH,0x00);
outportb(PORT+LCR,0x06);      /* set protocol, <7,N,2>=06H, <7,E,1>=1AH,
<7,O,1>=0AH, <8,N,2>=07H, <8,E,1>=1BH, <8,O,1>=0BH */
for(i=0;i<=16;i++){
while(!(inportb(PORT+LSR) & 0x20)); /* wait until THR empty */
outportb(PORT+THR,tdat[i]); /* send data to THR */ }
i=0;
while(!kbhit()){
if(inportb(PORT+LSR) & 0x01){ /* b0==1, read data ready */
rdat[i++]=inportb(PORT+RDR); /* read data form RDR */
} } }

```

09-05	↗ COM2 Transmission Speed (Keypad)	Unit: 0.1
--------------	------------------------------------	-----------

Control mode	VF	VFPG	SVC	FOCPG	TQCPG	Factory Setting: 9.6
---------------------	----	------	-----	-------	-------	----------------------

Settings	4.8 to 115.2kbps
----------	------------------

 **This parameter is used to set the transmission speed between the RS485 master (PLC, PC, etc.) and AC motor drive.**

09-06	↗ COM2 Transmission Fault Treatment (Keypad)	
--------------	--	--

Control mode	VF	VFPG	SVC	FOCPG	TQCPG	Factory Setting: 3
---------------------	----	------	-----	-------	-------	--------------------

Settings	0	Warn and keep operating
	1	Warn and RAMP to stop
	2	Warn and COAST to stop
	3	No warning and keep operating

 **This parameter is set to how to react if transmission errors occur.**

09-07 **↗** COM2 Time-out Detection (Keypad) Unit: 0.1

Control mode	VF	VFPG	SVC	FOCPG	TQCPG	Factory Setting: 0.0
Settings			0.0 ~ 100.0 sec			

If Pr.09-03 is not equal to 0.0, Pr.09-02=0~2, and there is no communication on the bus during the Time Out detection period (set by Pr.09-03), “cE10” will be shown on the keypad.

09-08 **↗** COM2 Communication Protocol (Keypad)

Control mode	VF	VFPG	SVC	FOCPG	TQCPG	Factory Setting: 13
Settings			0		Modbus ASCII mode, protocol <7,N,1>	
			1		Modbus ASCII mode, protocol <7,N,2>	
			2		Modbus ASCII mode, protocol <7,E,1>	
			3		Modbus ASCII mode, protocol <7,O,1>	
			4		Modbus ASCII mode, protocol <7,E,2>	
			5		Modbus ASCII mode, protocol <7,O,2>	
			6		Modbus ASCII mode, protocol <8,N,1>	
			7		Modbus ASCII mode, protocol <8,N,2>	
			8		Modbus ASCII mode, protocol <8,E,1>	
			9		Modbus ASCII mode, protocol <8,O,1>	
			10		Modbus ASCII mode, protocol <8,E,2>	
			11		Modbus ASCII mode, protocol <8,O,2>	
			12		Modbus RTU mode, protocol <8,N,1>	
			13		Modbus RTU mode, protocol <8,N,2>	
			14		Modbus RTU mode, protocol <8,E,1>	
			15		Modbus RTU mode, protocol <8,O,1>	
			16		Modbus RTU mode, protocol <8,E,2>	
			17		Modbus RTU mode, protocol <8,O,2>	

09-09 **↗** Response Delay Time Unit: 0.1

Control mode	VF	VFPG	SVC	FOCPG	TQCPG	Factory Setting: 2.0
Settings			0.0 ~ 200.0 msec			

This parameter is the response delay time after AC drive receives communication command as shown in the following.

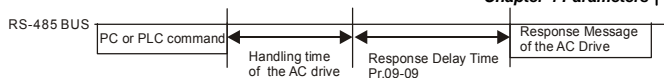

09-10	✗ Transmission Master Frequency					Unit: 0.01
Control mode	VF	VFPG	SVC	FOCPG	TQCPG	Factory Setting: 60.00
	Settings 0.00 ~ 600.00 Hz					

- When Pr.00-20 is set to 1 (RS485 communication). The AC motor drive will save the last frequency command into Pr.09-10 when abnormal turn-off or momentary power loss. After re-power on, it will with the frequency set in Pr.09-10 if there is no new frequency command.**

09-11	✗ Block Transfer 1					Unit: 1
09-12	✗ Block Transfer 2					Unit: 1
09-13	✗ Block Transfer 3					Unit: 1
09-14	✗ Block Transfer 4					Unit: 1
09-15	✗ Block Transfer 5					Unit: 1
09-16	✗ Block Transfer 6					Unit: 1
09-17	✗ Block Transfer 7					Unit: 1
09-18	✗ Block Transfer 8					Unit: 1
09-19	✗ Block Transfer 9					Unit: 1
09-20	✗ Block Transfer 10					Unit: 1
Control mode	VF	VFPG	SVC	FOCPG	TQCPG	Factory Setting: 0
	Settings 0 to 65535					

- There is a group of block transfer parameter available in the AC motor drive (Pr.09-11 to Pr.09-20). User can use them (Pr.09-11 to Pr.09-20) to save those parameters that you want to read.**

09-21	Multi-function Output Status					
Control mode	VF	VFPG	SVC	FOCPG	TQCPG	Factory Setting: Read-only
	Settings 0 to 65535					

09-22 Display Digital Value of Analog Output 2

Control mode	VF	VFPG	SVC	FOCPG	TQCPG	Factory Setting: Read-only
Settings	0 to 4095					

09-23 Display Digital Value of Analog Output 3

Control mode	VF	VFPG	SVC	FOCPG	TQCPG	Factory Setting: Read-only
Settings	0 to 4095					

 **Pr.09-22 and Pr.09-23 are used to communicate with multi-function extension card (EMV-APP01). Refer to Appendix B for details.**



 **When Pr.09-22 and Pr.09-23 are set to 4095, it corresponds to +10V.**

Group 10 PID Control

In this group, ASR is short for the Auto Speed Regulation and PG is short for Pulse Generator.

10-00	Encoder Pulse	Unit: 1
Control mode	VFGP FOCPG TQCPG	Factory Setting: 600
Settings	1 to 20000 (Max=20000 for 2-pole motor)	

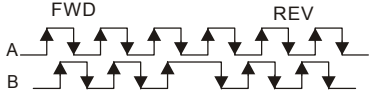
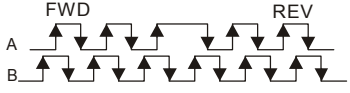
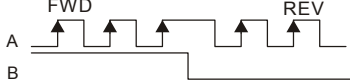
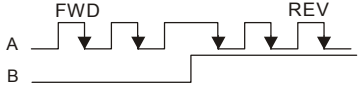
 **A Pulse Generator (PG) or encoder is used as a sensor that provides a feedback signal of the motor speed. This parameter defines the number of pulses for each cycle of the PG control.**

10-01	Encoder Input Type Setting	Factory Setting: 0
Control mode	VFGP FOCPG TQCPG	
Settings	<p>0 Disable</p> <p>Phase A leads in a forward run command and phase B leads in a reverse run command</p> <p>1</p>  <p>Phase B leads in a forward run command and phase A leads in a reverse run command</p> <p>2</p>  <p>Phase A is a pulse input and phase B is a direction input. (low input=reverse direction, high input=forward direction)</p> <p>3</p>  <p>Phase A is a pulse input and phase B is a direction input. (low input=forward direction, high input=reverse direction)</p> <p>4</p>  <p>5 Single-phase input</p> 	

10-02  Encoder Feedback Fault Treatment

Control mode	VFPG FOC PG TQCPG	Factory Setting: 2
Settings	0 Warn and keep operating 1 Warn and RAMP to stop 2 Warn and COAST to stop	

10-03  Detection Time for Encoder Feedback Fault Unit: 0.01

Control mode	VFPG FOC PG TQCPG	Factory Setting: 1.00
Settings	0.00 to 10.00 sec	

 **When encoder loss, encoder signal error, pulse signal setting error or signal error, if time exceeds the detection time for encoder feedback fault (Pr.10-03), the encoder signal error will occur. Refer to the Pr.10-02 for encoder feedback fault treatment.**

10-04  ASR (Auto Speed Regulation) control (P) 1 Unit: 0.1

Control mode	VFPG FOC PG TQCPG	Factory Setting: 10
Settings	0 to 40 Hz	

10-05  ASR (Auto Speed Regulation) control (I) 1 Unit: 0.001

Control mode	VFPG FOC PG TQCPG	Factory Setting: 0.100
Settings	0.000 to 10.000 sec	

10-06  ASR (Auto Speed Regulation) control (P) 2 Unit: 0.1

Control mode	VFPG FOC PG TQCPG	Factory Setting: 10
Settings	0 to 40Hz	

10-07  ASR (Auto Speed Regulation) control (I) 2 Unit: 0.001

Control mode	VFPG FOC PG TQCPG	Factory Setting: 0.100
Settings	0.000 to 10.000 sec	

10-21  P Gain of Zero Speed Unit: 1

Control mode	VFPG FOC PG TQCPG	Factory Setting: 10
Settings	0 to 40Hz	

10-22 ✓ I Gain of Zero Speed

Unit: 0.001

Control mode VFGP FOCPG TQCPG

Factory Setting: 0.100

Settings 0.000 to 10.000 sec

10-08 ✓ ASR 1/ASR2 Switch Frequency

Unit: 0.01

Control mode VFGP FOCPG TQCPG

Factory Setting: 7.00

Settings 5.00 or 600.00Hz

- 📖 When Pr.11-00 is set to bit0=1 (ASR), Pr.10-04~10-07 and Pr.10-21~10-22 are read-only.
- 📖 ASR P determines Proportional control and associated gain (P). ASR I determines integral control and associated gain (I).
- 📖 When integral time is set to 0, it is disabled. Pr.10-08 defines the switch frequency for the ASR1 (Pr.10-04, Pr.10-05) and ASR2 (Pr.10-06, Pr.10-07).

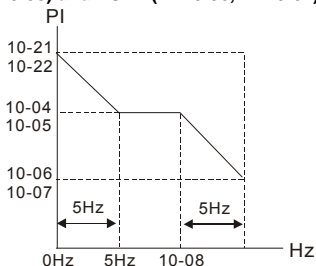

- 📖 When using multi-function input terminals to switch ASR1/ASR2, the diagram will be shown as follows.

Setting multi-function input terminal to 27
(ASR1/ASR2 switch)

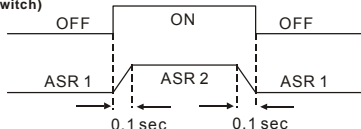
**10-09** ✓ Low Pass Filter Time of ASR Output

Unit: 0.001

Control mode FOCPG TQCPG

Factory Setting: 0.008

Settings 0.000 to 0.350 sec

- 📖 It defines the filter time of the ASR command.

10-10	↗ Encoder Stall Level	Unit: 1
Control mode	VFPG FOCPG	Factory Setting: 115
Settings	0 to 120% (0: disable)	

 **This parameter determines the maximum encoder feedback signal allowed before a fault occurs. (max. output frequency Pr.01-00 =100%)**

10-11	↗ Encoder Stall Detection Time	Unit: 0.1
Control mode	VFPG FOCPG	Factory Setting: 0.1
Settings	0.0 to 2.0 sec	

10-12	↗ Encoder Slip Range	Unit: 1
Control mode	VFPG FOCPG	Factory Setting: 50
Settings	0 to 50% (0: disable)	

10-13	↗ Encoder Slip Detection Time	Unit: 0.1
Control mode	VFPG FOCPG	Factory Setting: 0.5
Settings	0.0 to 10.0 sec	

10-14	↗ Encoder Stall and Slip Error Treatment	Factory Setting: 2
Control mode	VFPG FOCPG	
Settings	0	Warn and keep operating
	1	Warn and RAMP to stop
	2	Warn and COAST to stop

 **When the value of (rotation speed – motor frequency) exceeds Pr.10-12 setting, detection time exceeds Pr.10-13 or motor frequency exceeds Pr.10-10 setting, it will start to accumulate time. If detection time exceeds Pr.10-11, the encoder feedback signal error will occur. Refer to Pr.10-14 encoder stall and slip error treatment.**

10-15	↗ Pulse Input Type Setting	Factory Setting: 0
Control mode	VF VFPG SVC FOCPG TQCPG	
Settings	0	Disable

Phase A leads in a forward run command and phase B leads in a reverse run command

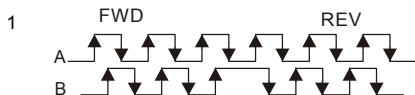

Phase B leads in a forward run command and phase A leads in a reverse run command



Phase A is a pulse input and phase B is a direction input. (low input=reverse direction, high input=forward direction)

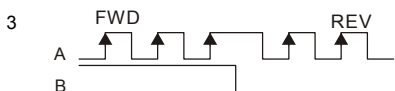

Phase A is a pulse input and phase B is a direction input. (low input=forward direction, high input=reverse direction)

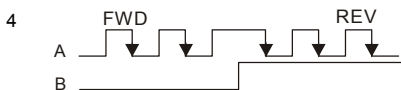

When this setting is different from Pr.10-01 setting and the source of the frequency command is pulse input (Pr.00-20 is set to 4 or 5), it may have 4 times frequency problem.

Example: Assume that Pr.10-00=1024, Pr.10-01=1, Pr.10-15=3, Pr.00-20=5, MI=37 and ON, it needs 4096 pulses to rotate the motor a revolution.

Assume that Pr.10-00=1024, Pr.10-01=1, Pr.10-15=1, Pr.00-20=5, MI=37 and ON, it needs 1024 pulses to rotate the motor a revolution.

10-16 Output Setting for Frequency Division (denominator)

Unit: 1

Control mode VFPG FOCPG TQCPG

Factory Setting: 1

Settings 1 to 255

This parameter is used to set the denominator for frequency division(for PG card EMV-PG01L or EMV-PG01O). For example, when it is set to 2 with feedback 1024ppr, PG output will be $1024/2=512$ ppr.

10-17	 Electrical Gear A (PG1 of PG card)	Unit: 1
Control mode	VFPG FOCPG	Factory Setting: 100
	Settings 1 to 5000	

10-18	 Electrical Gear B (PG2 of PG card)	Unit: 1
Control mode	VFPG FOCPG	Factory Setting: 100
	Settings 1 to 5000	

 **Rotation speed = pulse frequency/encoder pulse (Pr.10-00) * PG Electrical Gear A / PG Electrical Gear B.**

10-19	 Positioning for Encoder Position	Unit: 1
Control mode	VFPG FOCPG	Factory Setting: 0
	Settings 0 to 65535 pulses	

 **This parameter determines the internal position in the position mode.**

 **It needs to be used with multi-function input terminal setting =35 (enable position control).**

 **When it is set to 0, it is the Z-phase position of encoder.**

10-20	 Range for Encoder Position Attained	Unit: 1
Control mode	VFPG FOCPG	Factory Setting: 10
	Settings 0 to 20000 pulses	

 **This parameter determines the internal positioning position attained in the position control mode.**

10-23	 Feed Forward Gain of APR	Unit: 1
Control mode	VFPG FOCPG	Factory Setting: 30
	Settings 0 to 100	

 **For position control, the larger this parameter is set, the less pulse differential it will be and also make the position response be faster. But it may occur overshoot easily.**

 **When the multi-function input terminal is set to 37 (ON), this parameter can be set by requirement. If it is set to any value except 0 and adjust Pr.11-17 (Low-pass Filter Time of PG2 Pulse Input) to lessen position overshoot and pulse differential. If it is set to 0,**

position overshoot won't occur but the pulses differential is determined by Pr.11-18 (APR Gain).

10-24	✓ Deceleration Time for Internal Position/Waiting Time for Switching Max. Frequency	Unit: 0.01/0.1
Control mode	VFPG FOCPG	Factory Setting: 3.00/3.0
Settings	0.00 to 600.00 sec/0.0 to 6000.0 sec	

📖 When the multi-function input terminal is set to 35 (ON), this parameter setting will be the deceleration time for internal position.

📖 When the multi-function input terminal is set to 43 (ON), this parameter setting will be the waiting time for switching the max. frequency.

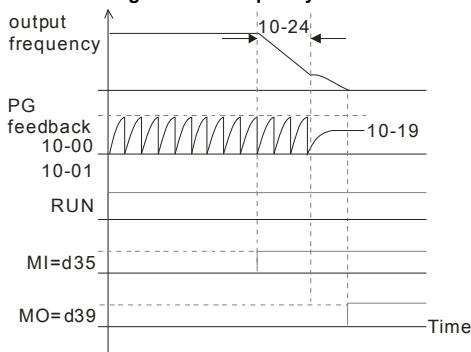

10-25	✓ Max. Frequency for Resolution Switch	Unit: 0.01
Control mode	VF VFPG SVC FOCPG TQCPG	Factory Setting: 50.00
Settings	0.00 to 600.00Hz	

📖 This function is used to enhance the function of unstable speed/position due to insufficient resolution of analog simulation value. It needs to use with external input terminals (one of Pr.02-01 to Pr.02-06/Pr.02-23 to Pr.02-30 should be set to 43). After setting this parameter, it needs to adjust the analog output resolution of controller.

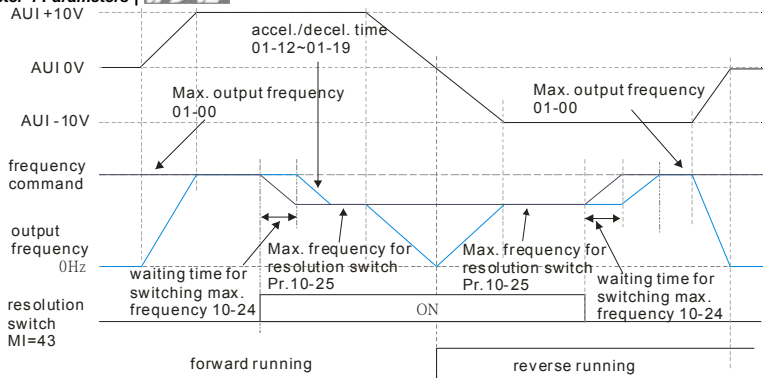

10-26 Reserved

10-27 \swarrow Mechanical Gear at Load A1 Unit: 1

10-28 \swarrow Mechanical Gear at Motor B1 Unit: 1

10-29 \swarrow Mechanical Gear at Load A2 Unit: 1

10-30 \swarrow Mechanical Gear at Motor B2 Unit: 1

Control mode VFPG FOC PG TQCPG Factory Setting: 100

Settings 1 to 65535

Parameters 10-27 to 10-30 can be used with the multi-function input terminal (set to 48) to switch to Pr.10-27~10-28 or Pr.10-29~10-30 as shown as follows.

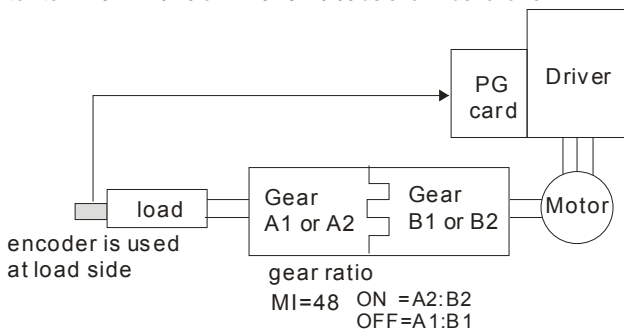

Group 11 Advanced Parameters

In this group, APR is short for Adjust Position Regulator.

11-00 System Control	
Control mode	FOCPG TQCPG Factory Setting: 0
Settings	Bit 0 Auto tuning for ASR and APR Bit 1 Inertia estimate (only in FOCPG mode) Bit 2 Zero Servo Bit 3 Reserved Bit 4 Enable gain adjustment of position loop KP

Bit 0=0: Pr.10-04~10-07, 10-21~10-22 and 11-18 will be valid and Pr.11-02~11-04 and 11-11 are invalid.

Bit 0=1: system will generate an ASR setting. At this moment, Pr. 10-04~10-07, 10-21~10-22 and Pr.11-18 will be invalid and Pr.11-02~11-04 and 11-11 are valid.

Bit 1=0: no function.

Bit 1=1: Inertia estimate function is enabled.

Bit 2=0: no function.

Bit 2=1: when frequency command is less than Fmin (Pr.01-07), it will use zero servo function.

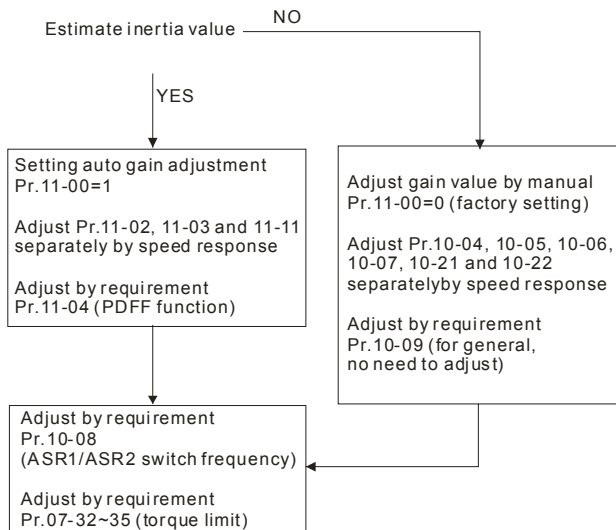

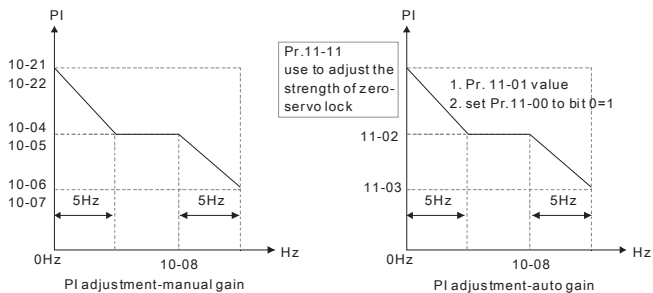
**11-01** Per Unit of System Inertia

Unit: 1

Control mode **FOCPG TQCPG**

Factory Setting: 400

Settings 1 to 65535 (256=1PU)

To get the system inertia from Pr.11-01, user needs to set Pr.11-00 to bit1=1 and execute continuous forward/reverse running.

11-02 Low-speed Bandwidth

Unit: 1

Control mode **VFPG FOCPG TQCPG**

Factory Setting: 10

Settings 0 to 40Hz

11-03 High-speed Bandwidth

Unit: 1

Control mode **VFPG FOCPG TQCPG**

Factory Setting: 10

Settings 0 to 40Hz

11-11 Zero-speed Bandwidth

Unit: 1

Control mode **VFPG FOCPG TQCPG**

Factory Setting: 10

Settings 0 to 40Hz

After estimating inertia and set Pr.11-00 to bit 0=1 (auto tuning), user can adjust parameters Pr.11-02, 11-03 and 11-11 separately by speed response. The larger number you set, the faster response you will get. Pr.10-08 is the switch frequency for low-speed/high-speed bandwidth.

11-04 PDF Gain Value

Unit: 1

Control mode **FOCPG**

Factory Setting: 30

Settings 0 to 200%

 After finishing estimating and set Pr.11-00 to bit 0=1 (auto tuning), using Pr.11-04 to reduce overshoot. Please adjust PDFF gain value by actual situation.

 This parameter will be invalid when Pr.05-12 is set to 1.

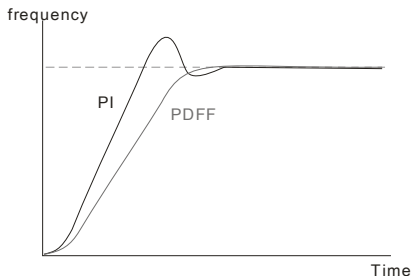

11-05	✓ Gain Value of Flux Weakening Curve for Motor 1	Unit: 1
--------------	--	---------

Control mode	FOCPG TQCPG	Factory Setting: 90
--------------	-------------	---------------------

Settings 0 to 200%

11-06	✓ Gain Value of Flux Weakening Curve for Motor 2	Unit: 1
--------------	--	---------

Control mode	FOCPG TQCPG	Factory Setting: 90
--------------	-------------	---------------------

Settings 0 to 200%

 Pr.11-05 is used to adjust the output voltage of flux weakening curve.

 For the spindle application, the adjustment method is

1. It is used to adjust the output voltage when exceeding rated frequency.
2. Monitor the output voltage
3. Adjust Pr.11-05 (motor 1) or Pr.11-06 (motor 2) setting to make the output voltage reach motor rated voltage.
4. The larger number it is set, the larger output voltage you will get.

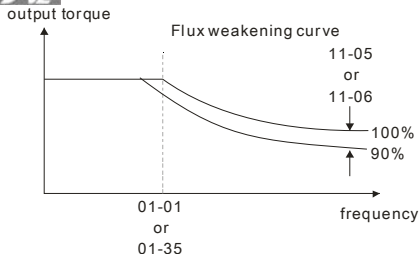

11-07 Detection Time for Phase-loss Unit: 0.01

Control mode	VF	VFPG	SVC	FOCPG	TQCPG	Factory Setting: 0.20
Settings	0.01 to 600.00 sec					

11-09 Level of Phase-loss Unit: 0.1

Control mode	VF	VFPG	SVC	FOCPG	TQCPG	Factory Setting: 60.0
Settings	0.0 to 320.0					

11-29 Accumulative Operation Time of Phase-loss Unit: 1

Control mode	VF	VFPG	SVC	FOCPG	TQCPG	Factory Setting: 0
Settings	0 to 65535 (hour)					

When the power phase-loss occurs and it exceeds the level (Pr.11-09) and the detection time(Pr.11-07), it will execute the phase-loss protection(Pr.06-02). The AC motor drive will record the operation time during phase-loss in Pr.11-29.

If it is set to 0 or a larger number, it will short the life of rectifier and capacitors in the AC motor drive.

11-08 Reserved

11-10 Speed Feed Forward Gain Unit: 1

Control mode	FOCPG	Factory Setting: 0
Settings	0 to 100%	

It is used to improve the speed response.

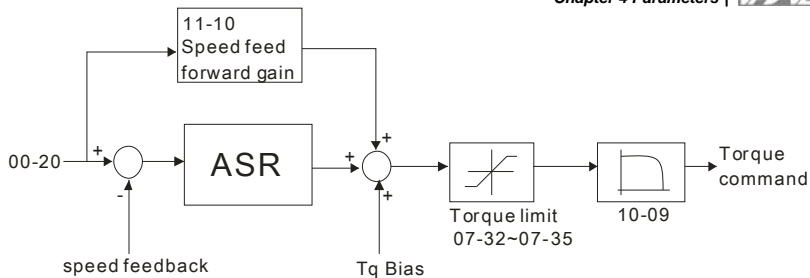

11-12	↗ Speed Response of Flux Weakening Area	Unit: 1
--------------	---	---------

Control mode	FOCPG	Factory Setting: 65
---------------------	-------	---------------------

Settings	0 to 150% (0: disable)
-----------------	------------------------

 **It is used to control the response speed for the flux weakening area. The larger number you set, the faster response you will get.**

11-13	↗ Notch Filter Depth	Unit: 1
--------------	----------------------	---------

Control mode	FOCPG	Factory Setting: 0
---------------------	-------	--------------------

Settings	0 to 20 db
-----------------	------------

11-14	↗ Notch Filter Frequency	Unit: 0.01
--------------	--------------------------	------------

Control mode	FOCPG	Factory Setting: 0.00
---------------------	-------	-----------------------

Settings	0.00 to 200.00
-----------------	----------------

 **This parameter is used to set resonance frequency of mechanical system. It can be used to suppress the resonance of mechanical system.**

 **The larger number you set Pr.11-13, the better suppression resonance function you will get.**

 **The notch filter frequency is the resonance of mechanical frequency.**

11-15	↗ Gain Value of Slip Compensation	Unit: 0.01
--------------	-----------------------------------	------------

Control mode	SVC	Factory Setting: 1.00
---------------------	-----	-----------------------

Settings	0.00 to 1.00
-----------------	--------------

 **It is only valid in SVC mode.**

 When the AC motor drive drives the asynchronous motor, slip will increase when the load is added. This parameter can be used to change frequency, lower slip and make the motor be synchronous when running under rated current. When the output current is higher than no-load current, the AC motor drive will adjust frequency by this parameter. If the actual speed is slower than expected, please increase the setting or decrease the setting.

11-16  Low-pass Filter Time of Keypad Display Unit: 0.001

Control mode	VF	VFPG	SVC	FOCPG	TQCPG	Factory Setting: 0.100
Settings	0.001 to 65.535 Sec					

 It is used to lower the blinking frequency of LCD display.

11-17  Low-pass Filter Time of PG2 Pulse Input Unit: 0.001

Control mode	VF	VFPG	SVC	FOCPG	Factory Setting: 0.100
Settings	0.000 to 65.535 Sec				

 It can be used to stable the speed command when Pr.00-20 is set to 5 and multi-function input terminal is set to 37 (OFF) to regard the pulse command as frequency command.

11-18  APR Gain Unit: 0.01

Control mode	FOCPG	Factory Setting: 10.00
Settings	0.00 to 40.00	

 It can be used to change the pulse differential when Pr.00-20 is set to 5, multi-function input terminal is set to 37 (ON) and Pr.11-00 is set to bit 0=0.

11-19  APR Curve Time Unit: 0.01

Control mode	FOCPG	Factory Setting: 3.00
Settings	0.00 to 655.35 sec	

 It is valid when the multi-function input terminal is set to 35(ON). The larger it is set, the longer the position time will be.

11-20	Reserved
11-28	Reserved

11-30

|

Reserved

11-40

This page intentionally left blank

Chapter 5 Troubleshooting

5.1 Over Current (OC)

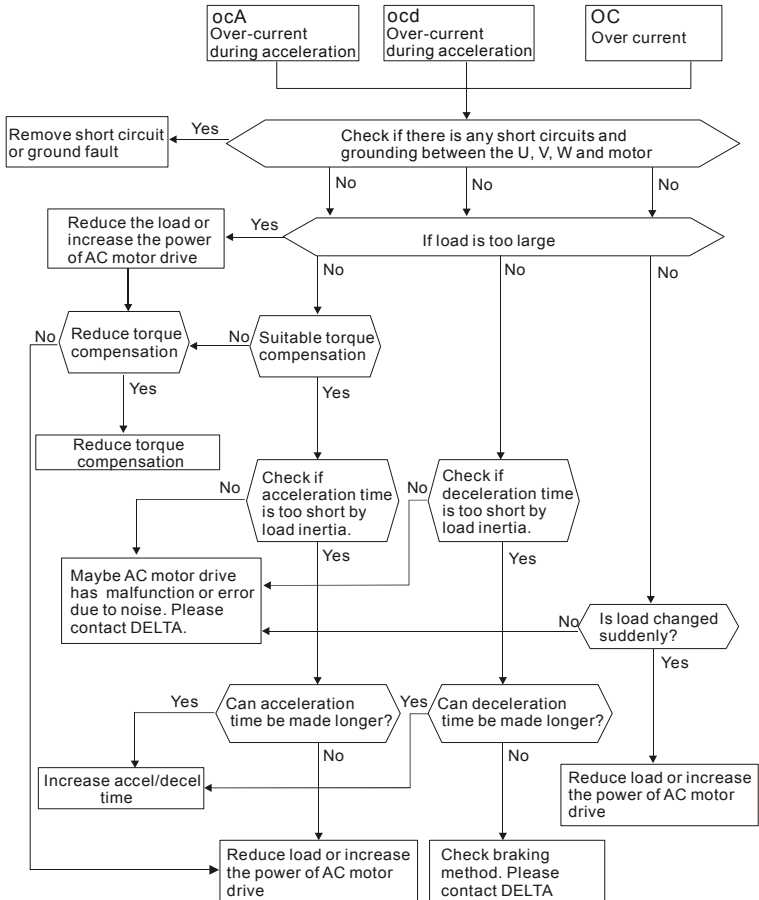

5.2 Ground Fault

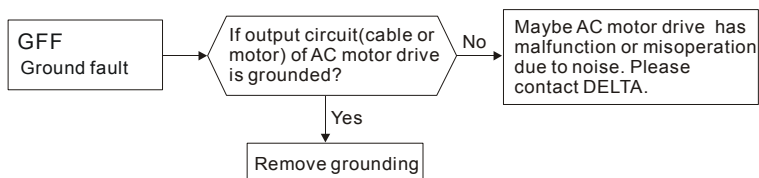

5.3 Over Voltage (OV)

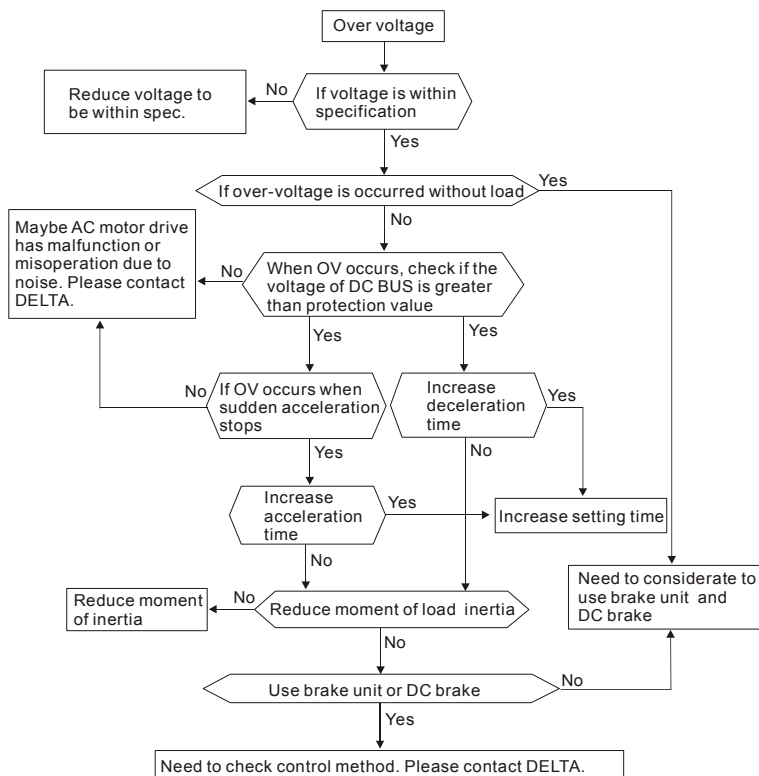

5.4 Low Voltage (Lv)

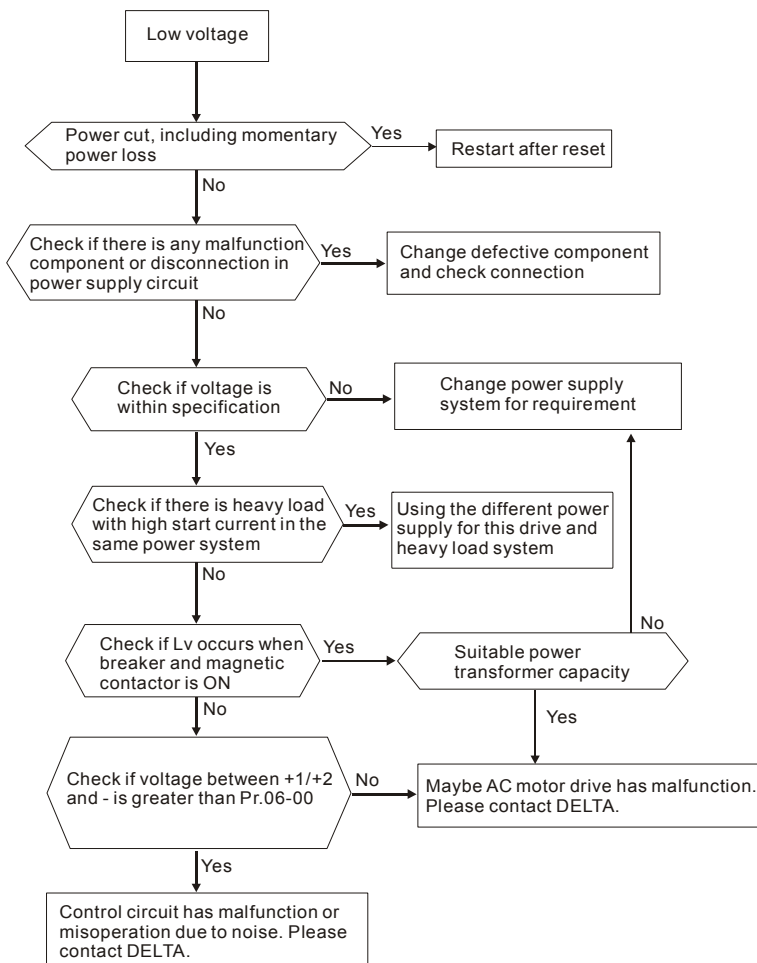

5.5 Over Heat (oH1, oH2, oH3)

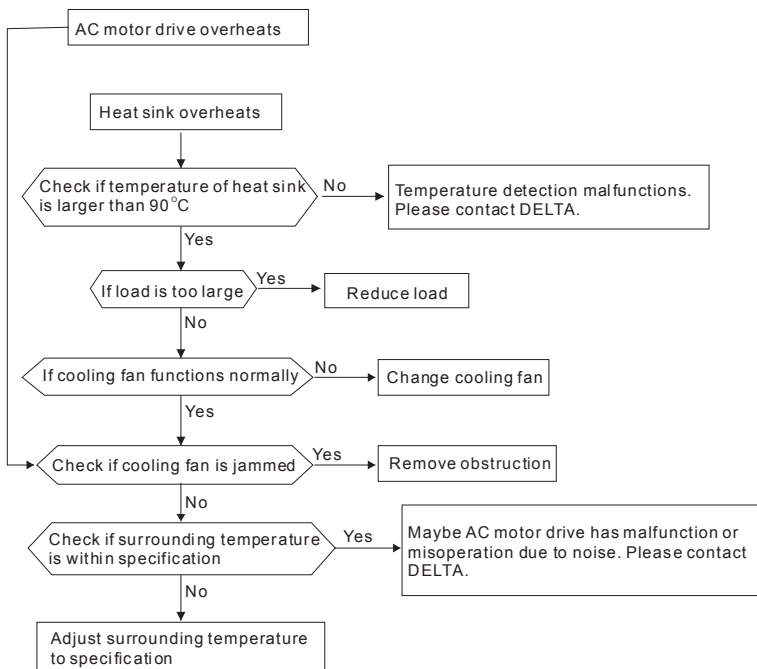

5.6 Overload

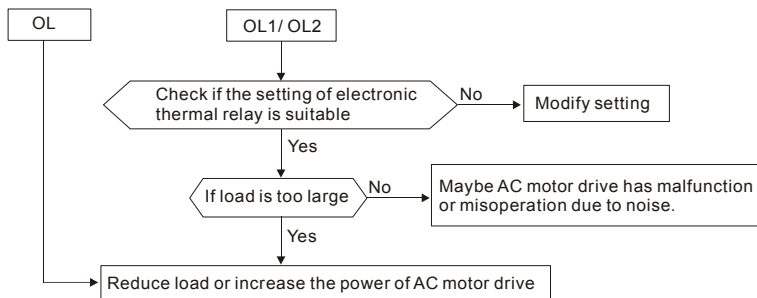

5.7 Display of KPV-CE01 is Abnormal

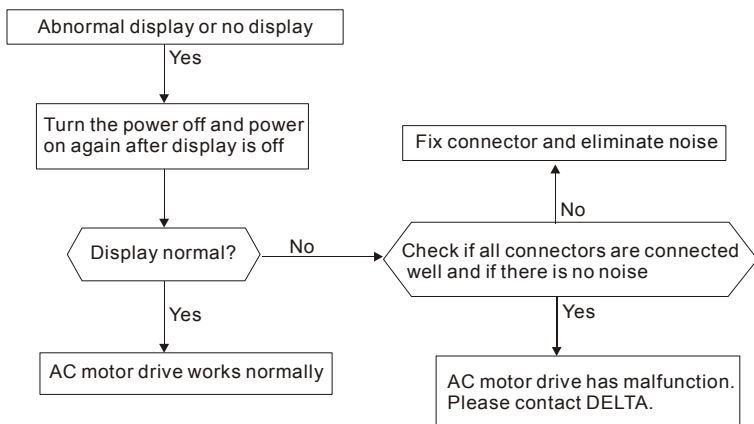

5.8 Phase Loss (PHL)

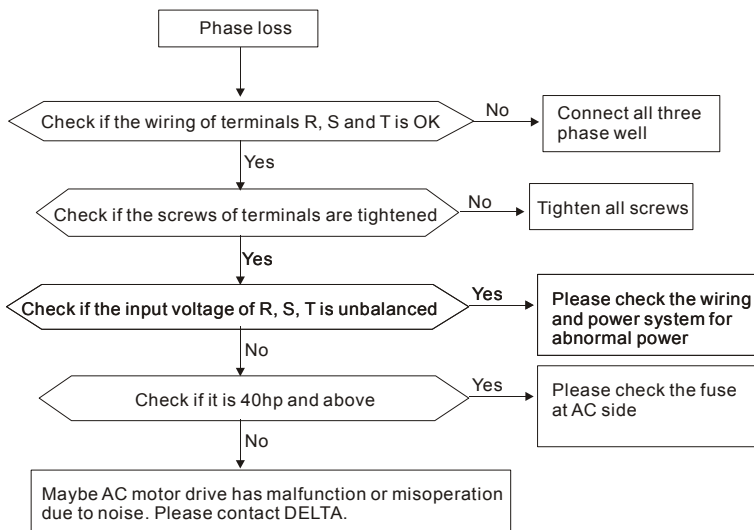

5.9 Motor cannot Run

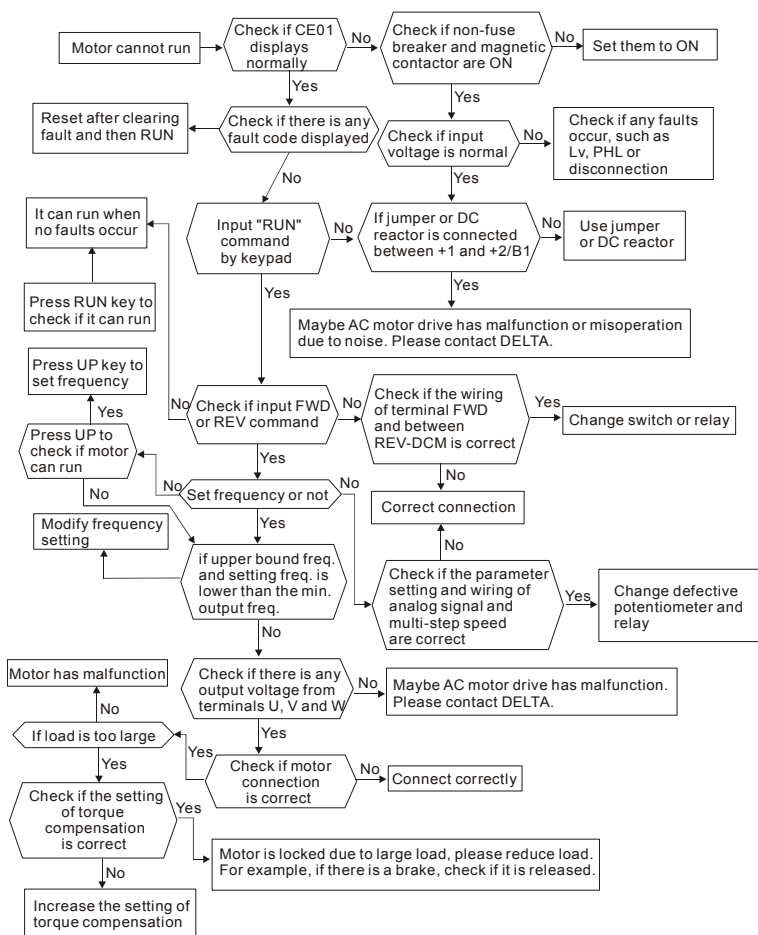

5.10 Motor Speed cannot be Changed

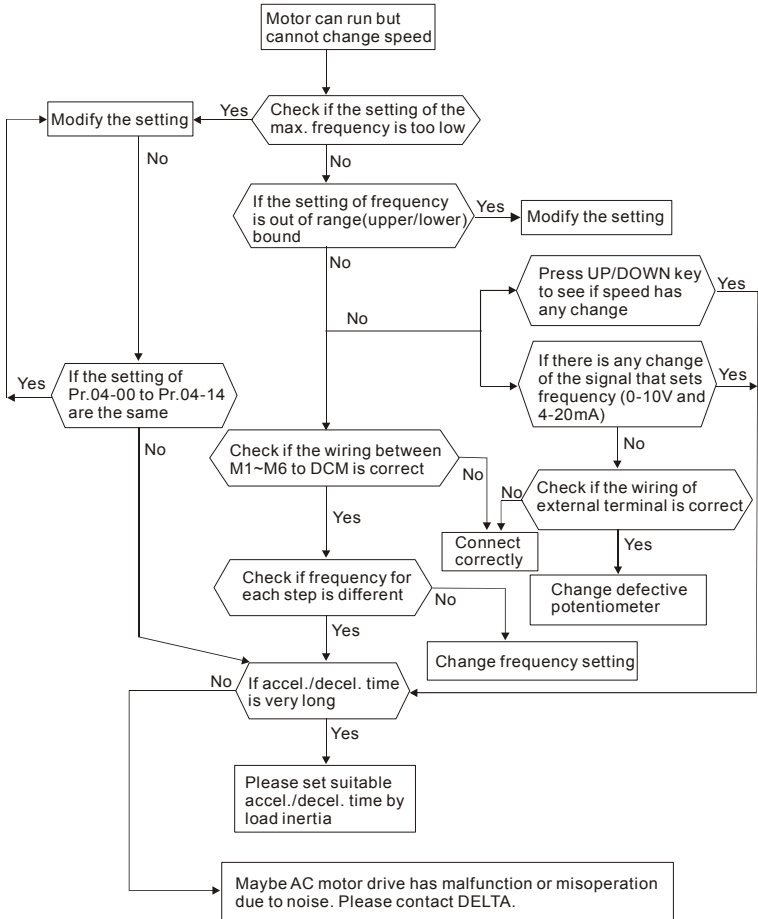

5.11 Motor Stalls during Acceleration

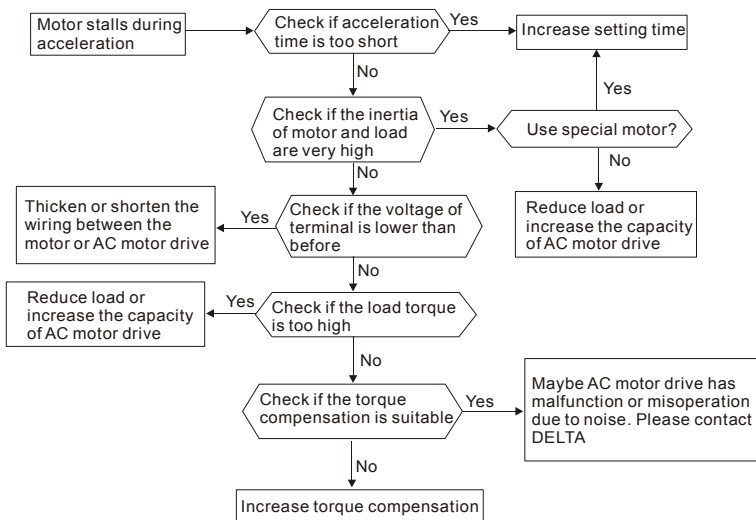

5.12 The Motor does not Run as Expected

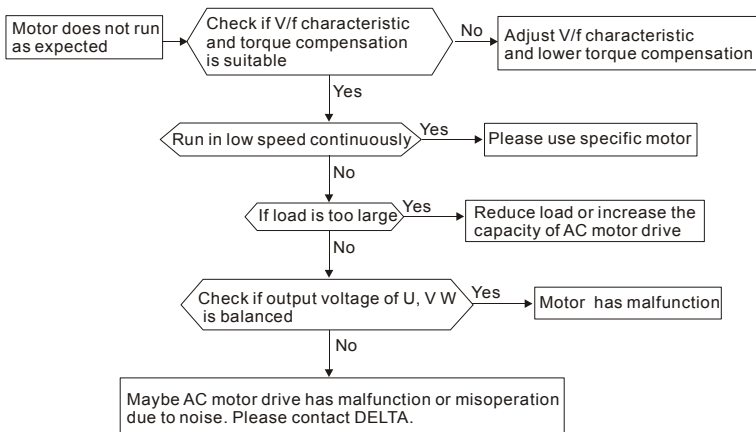

5.13 Electromagnetic/Induction Noise

There are many noises surround the AC motor drives and invade it by radiation or power circuit. It may cause the misoperation of control circuit and even damage the AC motor drive. Of course, that is a solution to increase the noise tolerance of AC motor drive. But it is not the best one due to the limit. Therefore, solve it from the outside as following will be the best.

1. Add surge killer on the relay or contact to suppress switching surge between ON/OFF.
2. Shorten the wiring length of the control circuit or serial circuit and separate from the main circuit wiring.
3. Comply with the wiring regulation for those shielded wire and use isolation amplifier for long wire.
4. The grounding terminal should comply with the local regulation and ground independently, i.e. not to have common ground with electric welding machine and power equipment.
5. Connect a noise filter at the input terminal of the AC motor drive to prevent noise from power circuit.

In a word, three-level solutions for electromagnetic noise are “no product”, “no spread” and “no receive”.

5.14 Environmental Condition

Since AC motor drive is an electronic device, you should comply with the environmental condition stated in the appendix A. Following are the remedial measures for necessary.

1. To prevent vibration, anti-vibration spacer is the last choice. The vibration tolerance must be within the specification. The vibration effect is equal to the mechanical stress and it cannot occur frequently, continuously or repeatedly to prevent damaging AC motor drive.
2. Store in a clean and dry location free from corrosive fumes/dust to prevent rustiness, poor contact. It also may cause short by low insulation in a humid location. The solution is to use both paint and dust-proof. For particular occasion, use the enclosure with whole-seal structure.
3. The surrounding temperature should be within the specification. Too high or low temperature will affect the lifetime and reliability. For semiconductor components, damage will occur once any specification is out of range. Therefore, it is necessary to clean and periodical check for the air cleaner and cooling fan besides having cooler and sunshade.

In addition, the microcomputer may not work in extreme low temperature and needs to have heater.

4. Store within a relative humidity range of 0% to 90% and non-condensing environment. Do not turn off the air conditioner and have exsiccator for it.

5.15 Affecting Other Machines

AC motor drive may affect the operation of other machine due to many reasons. The solutions are as follows.

■ High Harmonic at Power Side

If there is high harmonic at power side during running, the improved methods are:

1. Separate power system: use transformer for AC motor drive.
2. Use reactor at the power input terminal of AC motor drive or decrease high harmonic by multiple circuit.
3. If there is phase lead capacitor, it should use serial reactor to prevent capacitor damage from high harmonic.

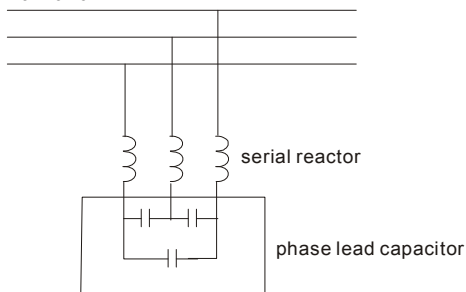

■ Motor Temperature Rises

When the motor is induction motor with ventilation-cooling-type used in variety speed operation, bad cooling will happen in the low speed. Therefore, it may overheat. Besides, high harmonic is in output waveform to increase copper loss and iron loss. Following measures should be used by load situation and operation range when necessary.

1. Use the motor with independent power ventilation or increase the horsepower.
2. Use inverter duty motor.
3. Do NOT run in the low speed

Chapter 6 Fault Code Information and Maintenance

6.1 Fault Code Information

The AC motor drive has a comprehensive fault diagnostic system that includes several different alarms and fault messages. Once a fault is detected, the corresponding protective functions will be activated. The following faults are displayed as shown on the AC motor drive digital keypad display. The six most recent faults can be read from the digital keypad or communication.



Wait 5 seconds after a fault has been cleared before performing reset via keypad of input terminal.

6.1.1 Common Problems and Solutions

Fault Name	Fault Descriptions	Corrective Actions
ocA	Over-current during acceleration (Output current exceeds triple rated current during acceleration.)	<ol style="list-style-type: none">1. Short-circuit at motor output: Check for possible poor insulation at the output lines.2. Acceleration Time too short: Increase the Acceleration Time.3. AC motor drive output power is too small: Replace the AC motor drive with the next higher power model.
ocd	Over-current during deceleration (Output current exceeds triple rated current during deceleration.)	<ol style="list-style-type: none">1. Short-circuit at motor output: Check for possible poor insulation at the output line.2. Deceleration Time too short: Increase the Deceleration Time.3. AC motor drive output power is too small: Replace the AC motor drive with the next higher power model.
ocn	Over-current during steady state operation (Output current exceeds triple rated current during constant speed.)	<ol style="list-style-type: none">1. Short-circuit at motor output: Check for possible poor insulation at the output line.2. Sudden increase in motor loading: Check for possible motor stall.3. AC motor drive output power is too small: Replace the AC motor drive with the next higher power model.
ocS	Hardware failure in current detection	Return to the factory

Fault Name	Fault Descriptions	Corrective Actions
GFF	Ground fault	<p>When (one of) the output terminal(s) is grounded, short circuit current is more than 50% of AC motor drive rated current, the AC motor drive power module may be damaged.</p> <p>NOTE: The short circuit protection is provided for AC motor drive protection, not for protection of the user.</p> <ol style="list-style-type: none"> 1. Check the wiring connections between the AC motor drive and motor for possible short circuits, also to ground. 2. Check whether the IGBT power module is damaged. 3. Check for possible poor insulation at the output line.
OCC	Short-circuit is detected between upper bridge and lower bridge of the IGBT module	Return to the factory
OVR	DC BUS over-voltage during acceleration (230V: DC 450V; 460V: DC 900V)	<ol style="list-style-type: none"> 1. Check if the input voltage falls within the rated AC motor drive input voltage range. 2. Check for possible voltage transients. 3. If DC BUS over-voltage due to regenerative voltage, please increase the Deceleration Time or add an optional brake resistor.
OVD	DC BUS over-voltage during deceleration (230V: DC 450V; 460V: DC 900V)	
OVC	DC BUS over-voltage in constant speed (230V: DC 450V; 460V: DC 900V)	
OVS	Hardware failure in voltage detection	Check if input voltage is within specification range and monitor if there is surge voltage.
LVR	DC BUS voltage is less than Pr.06-00 during acceleration	<ol style="list-style-type: none"> 1. Check if the input voltage is normal 2. Check for possible sudden load
LVD	DC BUS voltage is less than Pr.06-00 during deceleration	
LVC	DC BUS voltage is less than Pr.06-00 in constant speed	
LVS	DC BUS voltage is less than Pr.06-00 at stop	
PHL	Phase Loss	<p>Check Power Source Input if all 3 input phases are connected without loose contacts.</p> <p>For models 40hp and above, please check if the fuse for the AC input circuit is blown.</p>

Fault Name	Fault Descriptions	Corrective Actions
OH1	IGBT overheating IGBT temperature exceeds protection level 1 to15HP: 90 °C 20 to 100HP: 100 °C	<ol style="list-style-type: none"> 1. Ensure that the ambient temperature falls within the specified temperature range. 2. Make sure that the ventilation holes are not obstructed. 3. Remove any foreign objects from the heatsinks and check for possible dirty heat sink fins. 4. Check the fan and clean it. 5. Provide enough spacing for adequate ventilation.
OH2	Heatsink overheating Heat sink temperature exceeds 90°C	<ol style="list-style-type: none"> 1. Ensure that the ambient temperature falls within the specified temperature range. 2. Make sure that the ventilation holes are not obstructed. 3. Remove any foreign objects from the heatsinks and check for possible dirty heat sink fins. 4. Check the fan and clean it. 5. Provide enough spacing for adequate ventilation.
OH3	Motor overheating The AC motor drive detects that the internal temperature exceeds Pr.06-30 (PTC level)	<ol style="list-style-type: none"> 1. Make sure that the motor is not obstructed. 2. Ensure that the ambient temperature falls within the specified temperature range. 3. Take the next higher power AC motor drive model.
EH10	OH1 hardware failure	Return to the factory
EH20	OH2 hardware failure	Return to the factory
FRn	Fan failure	<ol style="list-style-type: none"> 1. Make sure that the fan is not obstructed. 2. Return to the factory
OL	Overload The AC motor drive detects excessive drive output current. NOTE: The AC motor drive can withstand up to 150% of the rated current for a maximum of 60 seconds.	<ol style="list-style-type: none"> 1. Check whether the motor is overloaded. 2. Take the next higher power AC motor drive model.
EOL1	Electronics thermal relay 1 protection	<ol style="list-style-type: none"> 1. Check the setting of electronics thermal relay (Pr.06-14) 2. Take the next higher power AC motor drive model
EOL2	Electronics thermal relay 2 protection	<ol style="list-style-type: none"> 1. Check the setting of electronics thermal relay (Pr.06-28) 2. Take the next higher power AC motor drive model
FUSE	Broken fuse The fuse at DC side is broken for 30hp and below	<ol style="list-style-type: none"> 1. Check whether the fuse of the transistor module is functioning well 2. Check whether the loading side is short-circuit

Fault Name	Fault Descriptions	Corrective Actions
ot 1	These two fault codes will be displayed when output current exceeds the over-torque detection level (Pr.06-07 or Pr.06-10) and exceeds over-torque detection(Pr.06-08 or Pr.06-11) and it is set 2 or 4 in Pr.06-06 or Pr.06-09.	<ol style="list-style-type: none"> 1. Check whether the motor is overloaded. 2. Check whether motor rated current setting (Pr.05-01) is suitable 3. Take the next higher power AC motor drive model.
ot 2		
cF 1	Internal EEPROM can not be programmed.	<ol style="list-style-type: none"> 1. Press "RESET" key to the factory setting 2. Return to the factory.
cF 2	Internal EEPROM can not be read.	<ol style="list-style-type: none"> 1. Press "RESET" key to the factory setting 2. Return to the factory.
cd0	Isum error	Re-power on to try it. If fault code is still displayed on the keypad please return to the factory
cd 1	U-phase error	
cd 2	V-phase error	
cd 3	W-phase error	
Hd0	CC (current clamp)	Re-power on to try it. If fault code is still displayed on the keypad please return to the factory
Hd 1	OC hardware error	
Hd 2	OV hardware error	
Hd 3	GFF hardware error	
AUE	Auto tuning error	<ol style="list-style-type: none"> 1. Check cabling between drive and motor 2. Retry again
AFE	PID loss (ACI)	<ol style="list-style-type: none"> 1. Check the wiring of the PID feedback 2. Check the PID parameters settings
PGF 1	PG feedback error	Check if Pr.10-01 is set to 0 when it is PG feedback control
PGF 2	PG feedback loss	Check the wiring of the PG feedback
PGF 3	PG feedback stall	<ol style="list-style-type: none"> 1. Check the wiring of the PG feedback 2. Check if the setting of PI gain and deceleration is suitable 3. Return to the factory
PGF 4	PG slip error	
PGr 1	Pulse input error	<ol style="list-style-type: none"> 1. Check the pulse wiring 2. Return to the factory
PGr 2	Pulse input loss	
ACE	ACI loss	<ol style="list-style-type: none"> 1. Check the ACI wiring 2. Check if the ACI signal is less than 4mA
EF	External Fault	<ol style="list-style-type: none"> 1. Input EF (N.O.) on external terminal is closed to GND. Output U, V, W will be turned off. 2. Give RESET command after fault has been cleared.
EF 1	Emergency stop	<ol style="list-style-type: none"> 1. When the multi-function input terminals MI1 to MI6 are set to emergency stop, the AC motor drive stops output U, V, W and the motor coasts to stop. 2. Press RESET after fault has been cleared.

Fault Name	Fault Descriptions	Corrective Actions
bb	External Base Block	<ol style="list-style-type: none"> When the external input terminal (B.B) is active, the AC motor drive output will be turned off. Deactivate the external input terminal (B.B) to operate the AC motor drive again.
PcodE	Password is locked.	Keypad will be locked. Turn the power ON after power OFF to re-enter the correct password. See Pr.00-07 and 00-08.
cE1	Illegal function code	Check if the function code is correct (function code must be 03, 06, 10, 63)
cE2	Illegal data address (00H to 254H)	Check if the communication address is correct
cE3	Illegal data value	Check if the data value exceeds max./min. value
cE4	Data is written to read-only address	Check if the communication address is correct
cE10	Communication time-out COM1: exceeds Pr.09-03 setting, COM2: exceeds Pr.09-07 setting	Check if the wiring for the communication is correct
cP10	Keypad (KPV-CE01) communication time-out COM1: exceeds Pr.09-03 setting, COM2: exceeds Pr.09-07 setting	<ol style="list-style-type: none"> Check if the wiring for the communication is correct Check if there is any wrong with the keypad
bF	Brake resistor fault	If the fault code is still displayed on the keypad after pressing "RESET" key, please return to the factory.
Ydc	Y-connection/Δ-connection switch error	<ol style="list-style-type: none"> Check the wiring of the Y-connection/Δ-connection Check the parameters settings
dEb	When Pr.07-13 is not set to 0 and momentary power off or power cut, it will display dEb during accel./decel. stop.	<ol style="list-style-type: none"> Set Pr.07-13 to 0 Check if input power is stable
oSL	It will be displayed when slip exceeds Pr.05-26 setting and time exceeds Pr.05-27 setting.	<ol style="list-style-type: none"> Check if motor parameter is correct (please decrease the load if overload) Check the settings of Pr.05-26 and Pr.05-27

Fault Name	Fault Descriptions	Corrective Actions
bEb	It will be displayed when broken belt detection function is enabled(Pr.08-59), allowance error is higher than Pr.08-61 and detection time exceeds Pr.08-62.	<ol style="list-style-type: none"> 1. Check if the belt is broken 2. Check the settings of Pr.08-60, Pr.08-62 and Pr.08-63
bEj	It will be displayed when the allowance error of tension PID feedback exceeds Pr.08-63 setting and allowance error detection time exceeds Pr.08-64 setting.	<ol style="list-style-type: none"> 1. Check if the PID feedback is correct 2. Check if the material is broken 3. Check the settings of Pr.08-63 and Pr.08-64

6.1.2 Reset

There are three methods to reset the AC motor drive after solving the fault:

1. Press  key on KPV-CE01.
2. Set external terminal to "RESET" (set one of Pr.02-01~Pr.02-06/ Pr.02-23~Pr.02-30 to 5) and then set to be ON.
3. Send "RESET" command by communication.

NOTE

Make sure that RUN command or signal is OFF before executing RESET to prevent damage or personal injury due to immediate operation.

6.2 Maintenance and Inspections

Modern AC motor drives are based on solid state electronics technology. Preventive maintenance is required to operate this AC motor drive in its optimal condition, and to ensure a long life. It is recommended to have a check-up of the AC motor drive performed by a qualified technician.

Daily Inspection:

Basic check-up items to detect if there were any abnormalities during operation are:

1. Whether the motors are operating as expected.
2. Whether the installation environment is abnormal.
3. Whether the cooling system is operating as expected.
4. Whether any irregular vibration or sound occurred during operation.
5. Whether the motors are overheating during operation.
6. Always check the input voltage of the AC drive with a Voltmeter.

Periodic Inspection:

Before the check-up, always turn off the AC input power and remove the cover. Wait at least 10 minutes after all display lamps have gone out, and then confirm that the capacitors have fully discharged by measuring the voltage between +1/+2 and -. The voltage between +1/+2 and-should be less than 25VDC.



DANGER!

-
1. Disconnect AC power before processing!
 2. Only qualified personnel can install, wire and maintain AC motor drives. Please take off any metal objects, such as watches and rings, before operation. And only insulated tools are allowed.
 3. Never reassemble internal components or wiring.
 4. Prevent static electricity.

Periodical Maintenance

■ Ambient environment

Check Items	Methods and Criterion	Maintenance Period		
		Daily	Half Year	One Year
Check the ambient temperature, humidity, vibration and see if there are any dust, gas, oil or water drops	Visual inspection and measurement with equipment with standard specification	○		
If there are any dangerous objects	Visual inspection	○		

■ Voltage

Check Items	Methods and Criterion	Maintenance Period		
		Daily	Half Year	One Year
Check if the voltage of main circuit and control circuit is correct	Measure with multimeter with standard specification	○		

■ Keypad

Check Items	Methods and Criterion	Maintenance Period		
		Daily	Half Year	One Year
Is the display clear for reading	Visual inspection	○		
Any missing characters	Visual inspection	○		

■ Mechanical parts

Check Items	Methods and Criterion	Maintenance Period		
		Daily	Half Year	One Year
If there is any abnormal sound or vibration	Visual and aural inspection		○	
If there are any loose screws	Tighten the screws		○	

Check Items	Methods and Criterion	Maintenance Period		
		Daily	Half Year	One Year
If any part is deformed or damaged	Visual inspection		○	
If there is any color change by overheating	Visual inspection		○	
If there is any dust or dirt	Visual inspection		○	

■ Main circuit

Check Items	Methods and Criterion	Maintenance Period		
		Daily	Half Year	One Year
If there are any loose or missing screws	Tighten or replace the screw		○	
If machine or insulator is deformed, cracked, damaged or with color change due to overheating or ageing	Visual inspection NOTE: Please ignore the color change of copper plate		○	
If there is any dust or dirt	Visual inspection		○	

■ Terminals and wiring of main circuit

Check Items	Methods and Criterion	Maintenance Period		
		Daily	Half Year	One Year
If the terminal or the plate is color change or deformation due to overheat	Visual inspection		○	
If the insulator of wiring is damaged or color change	Visual inspection		○	
If there is any damage	Visual inspection		○	

■ **DC capacity of main circuit**

Check Items	Methods and Criterion	Maintenance Period		
		Daily	Half Year	One Year
If there is any leak of liquid, color change, crack or deformation	Visual inspection	○		
Measure static capacity when required	Static capacity \geq initial value X 0.85		○	

■ **Resistor of main circuit**

Check Items	Methods and Criterion	Maintenance Period		
		Daily	Half Year	One Year
If there is any peculiar smell or insulator cracks due to overheat	Visual inspection, smell		○	
If there is any disconnection	Visual inspection or measure with multimeter after removing wiring between +1/+2 ~ - Resistor value should be within $\pm 10\%$		○	

■ **Transformer and reactor of main circuit**

Check Items	Methods and Criterion	Maintenance Period		
		Daily	Half Year	One Year
If there is any abnormal vibration or peculiar smell	Visual, aural inspection and smell		○	

■ **Magnetic contactor and relay of main circuit**

Check Items	Methods and Criterion	Maintenance Period		
		Daily	Half Year	One Year
If there are any loose screws	Visual and aural inspection	○		
If the contact works correctly	Visual inspection	○		

■ Printed circuit board and connector of main circuit

Check Items	Methods and Criterion	Maintenance Period		
		Daily	Half Year	One Year
If there are any loose screws and connectors	Tighten the screws and press the connectors firmly in place.		○	
If there is any peculiar smell and color change	Visual inspection		○	
If there is any crack, damage, deformation or corrosion	Visual inspection		○	
If there is any liquid is leaked or deformation in capacity	Visual inspection		○	

■ Cooling fan of cooling system

Check Items	Methods and Criterion	Maintenance Period		
		Daily	Half Year	One Year
If there is any abnormal sound or vibration	Visual, aural inspection and turn the fan with hand (turn off the power before operation) to see if it rotates smoothly			○
If there is any loose screw	Tighten the screw			○
If there is any color change due to overheat	Change fan			○

■ Ventilation channel of cooling system



Check Items	Methods and Criterion	Maintenance Period		
		Daily	Half Year	One Year
If there is any obstruction in the heat sink, air intake or air outlet	Visual inspection	○		

This page intentionally left blank

Appendix A Specifications

Voltage Class		230V Class											
Model Number VFD-XXXV		007	015	022	037	055	075	110	150	185	220	300	370
Max. Applicable Motor Output (kW)		0.75	1.5	2.2	3.7	5.5	7.5	11	15	18.5	22	30	37
Max. Applicable Motor Output (hp)		1.0	2.0	3.0	5.0	7.5	10	15	20	25	30	40	50
Output Rating	Rated Output Capacity (kVA)	1.9	2.7	4.2	6.5	9.5	13	19	25	29	34	46	55
	Rated Output Current for Constant Torque (A)	5.0	7.5	11	17	25	33	49	65	75	90	120	146
	Rated Output Current for Variable Torque (A)	6.25	9.4	13	21	31	41	61	81	93	112	150	182
	Maximum Output Voltage (V)	3-Phase Proportional to Input Voltage											
Output Frequency (Hz)		0.00~600.00 Hz											
Carrier Frequency (kHz)		15				9				6			
Input Rating	Rated Input Current (A)	6.4	9.9	15	21	25	33	52	63	68	79	106	126
	Rated Voltage/Frequency	3-phase 200-240V, 50/60Hz											
	Voltage Tolerance	± 10%(180~264 V)											
	Frequency Tolerance	± 5%(47~63 Hz)											
Cooling Method		Natural	Fan Cooled										
Weight (kg)		2.7	3.2	4.5	6.8	8	10	13	13	13	13	36	36

Voltage Class		460V Class														
Model Number VFD-XXXV		007	015	022	037	055	075	110	150	185	220	300	370	450	550	750
Max. Applicable Motor Output (kW)		0.75	1.5	2.2	3.7	5.5	7.5	11	15	18.5	22	30	37	45	55	75
Max. Applicable Motor Output (hp)		1.0	2.0	3.0	5.0	7.5	10	15	20	25	30	40	50	60	75	100
Output Rating	Rated Output Capacity (kVA)	2.3	3.2	4.2	6.3	9.9	14	18	24	29	34	46	56	69	80	100
	Rated Output Current for Constant Torque (A)	3.0	4.2	6.0	8.5	13	18	24	32	38	45	60	73	91	110	150
	Rated Output Current for Variable Torque (A)	3.8	5.3	7.5	10	16	22	30	40	47	56	75	91	113	138	188
	Maximum Output Voltage (V)	3-phase Proportional to Input Voltage														
Output Frequency (Hz)		0.00~600.00 Hz														
Carrier Frequency (kHz)		15				9				6						
Input Rating	Rated Input Current (A)	3-phase 380~480V														
	Rated Voltage	4.0	5.8	7.4	9.9	12	17	25	27	35	42	56	67	87	101	122
	Voltage Tolerance	± 10%(342~528 V)														
	Frequency Tolerance	± 5%(47~63 Hz)														
Cooling Method		Natural	Fan Cooled													
Weight (kg)		2.7	3.2	4.5	6.8	8	10	13	13	13	36	36	36	50	50	

General Specifications		
Control Characteristics	Control System	1 V/f curve; 2 V/f+PG; 3 SVC; 4 FOC+PG; 5 TQR+PG
	Start Torque	Starting torque is 150% at 0.5Hz and 0Hz with FOC + PG control mode
	Speed Control Range	1:100 Sensorless vector (up to 1:1000 when using PG card)
	Speed Control Resolution	$\pm 0.5\%$ Sensorless vector (up to $\pm 0.02\%$ when using PG card)
	Speed Response Ability	5Hz (up to 30Hz for vector control)
	Max. Output Frequency	0.00 to 600.00Hz
	Output Frequency Accuracy	Digital command $\pm 0.005\%$, analog command $\pm 0.5\%$
	Frequency Setting Resolution	Digital command $\pm 0.01\text{Hz}$, analog command: 1/4096(12-bit) of the max. output frequency
	Torque Limit	Max. is 200% torque current
	Torque Accuracy	$\pm 5\%$
	Accel/Decel Time	0.00 to 600.00/0.0 to 6000.0 seconds
	V/f Curve	Adjustable V/f curve using 4 independent points and square curve
	Protection Characteristics	Frequency Setting Signal
Brake Torque		About 20%
Motor Protection		Electronic thermal relay protection
Over-current Protection		The current forces 220% of the over-current protection and 300% of the rated current
Ground Leakage Current Protection		Higher than 50% X rated current
Overload Ability		Constant torque: 150% for 60 seconds, variable torque: 200% for 3 seconds
Over-voltage Protection		Over-voltage level: Vdc > 400/800V; low-voltage level: Vdc < 200/400V
Over-voltage Protection for the Input Power		Varistor (MOV)
Over-temperature Protection		Built-in temperature sensor
Compensation for the Momentary Power Loss		Up to 5 seconds for parameter setting
Environmental Conditions	Protection Level	NEMA 1/IP21
	Operation Temperature	-10°C to 40°C
	Storage Temperature	-20 °C to 60 °C
	Ambient Humidity	Below 90% RH (non-condensing)
	Vibration	9.80665m/s ² (1G) less than 20Hz, 5.88m/s ² (0.6G) at 20 to 50Hz
	Installation Location	Altitude 1,000 m or lower, keep from corrosive gasses, liquid and dust
Certifications	  	

Appendix B Accessories

B.1 All Brake Resistors & Brake Units Used in AC Motor Drives

Note: Please only use DELTA resistors and recommended values. Other resistors and values will void Delta's warranty. Please contact your nearest Delta representative for use of special resistors. For instance, in 460V series, 100hp/75kW, the AC motor drive needs 2 brake units with total of 16 brake resistors, so each brake unit uses 8 brake resistors. The brake unit should be at least 10 cm away from AC motor drive to avoid possible interference. Refer to the "Brake Unit Module User Manual" for further details.

Voltage	Applicable Motor		Full Load Torque Nm	Resistor value spec for each AC Motor Drive	Brake Unit Model VFDB No. of Units Used		Brake Resistors Model and No. of Units Used	Brake Torque 10%ED	Min. Equivalent Resistor Value for each AC Motor Drive	
	hp	kW								
230V Series	1	0.75	0.427	80W 200Ω			BR080W200	1	125	82Ω
	2	1.5	0.849	300W 100Ω			BR300W100	1	125	82Ω
	3	2.2	1.262	300W 100Ω			BR300W100	1	125	82Ω
	5	3.7	2.080	400W 40Ω			BR400W040	1	125	33Ω
	7.5	5.5	3.111	500W 30Ω			BR500W030	1	125	30Ω
	10	7.5	4.148	1000W 20Ω			BR1K0W020	1	125	20Ω
	15	11	6.186	2400W 13.6Ω	2015	1	BR1K2W6P8	2	125	13.6Ω
	20	15	8.248	3000W 10Ω	2015	1	BR1K5W005	2	125	10Ω
	25	18.5	10.281	4800W 8Ω	2022	1	BR1K2W008	4	125	8Ω
	30	22	12.338	4800W 6.8Ω	2022	1	BR1K2W6P8	4	125	6.8Ω
	40	30	16.497	6000W 5Ω	2015	2	BR1K5W005	4	125	5Ω
50	37	20.6	9600W 4Ω	2015	2	BR1K2W008	8	125	4Ω	
460V Series	1	0.75	0.427	80W 750Ω			BR080W750	1	125	160Ω
	2	1.5	0.849	300W 400Ω			BR300W400	1	125	160Ω
	3	2.2	1.262	300W 250Ω			BR300W250	1	125	160Ω
	5	3.7	2.080	400W 150Ω			BR400W150	1	125	130Ω
	7.5	5.5	3.111	500W 100Ω			BR500W100	1	125	91Ω
	10	7.5	4.148	1000W 75Ω			BR1K0W075	1	125	62Ω
	15	11	6.186	1000W 50Ω	4030	1	BR1K0W050	1	125	39Ω
	20	15	8.248	1500W 40Ω	4030	1	BR1K5W040	1	125	40Ω
	25	18.5	10.281	4800W 32Ω	4030	1	BR1K2W008	4	125	32Ω
	30	22	12.338	4800W 27.2Ω	4030	1	BR1K2W6P8	4	125	27.2Ω
	40	30	16.497	6000W 20Ω	4030	1	BR1K5W005	4	125	20Ω
	50	37	20.6	9600W 16Ω	4045	1	BR1K2W008	8	125	16Ω
	60	45	24.745	9600W 13.6Ω	4045	1	BR1K2W6P8	8	125	13.6Ω
75	55	31.11	12000W 10Ω	4030	2	BR1K5W005	8	125	10Ω	
100	75	42.7	19200W 6.8Ω	4045	2	BR1K2W6P8	16	125	6.8Ω	



NOTE

Appendix B Accessories | VFD-VE

1. Please select the factory setting resistance value (Watt) and the duty-cycle value (ED%).
2. If damage to the drive or other equipment are due to the fact that the brake resistors and the brake modules in use are not provided by Delta, the warranty will be void.
3. Take into consideration the safety of the environment when installing the brake resistors.
4. If the minimum resistance value is to be utilized, consult local dealers for the calculation of the Watt figures.
5. Please select thermal relay trip contact to prevent resistor over load. Use the contact to switch power off to the AC motor drive!
6. When using more than 2 brake units, equivalent resistor value of parallel brake unit can't be less than the value in the column "Minimum Equivalent Resistor Value for Each AC Drive" (the right-most column in the table). An example of 575V 100HP, the min. equivalent resistor value for each AC motor drive is 12.5Ω with 2 brake units connection. Therefore, the equivalent resistor value for each brake unit should be 25Ω.
7. Please read the wiring information in the user manual of brake unit thoroughly prior to taking into operation.
8. Definition for Brake Usage ED%

Explanation: The definition of the barke usage ED(%) is for assurance of enough time for the brake unit and brake resistor to dissipate away heat generated by braking. When the brake resistor heats up, the resistance would increase with temperature, and brake torque would decrease accordingly. Suggested cycle time is one minute

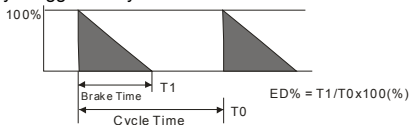

9. For safety consideration, install an overload relay between the brake unit and the brake resistor. In conjunction with the magnetic contactor (MC) prior to the drive, it can perform complete protection against abnormality. The purpose of installing the thermal overload relay is to protect the brake resistor from damage due to frequent brake, or due to brake unit keeping operating resulted from unusual high input voltage. Under such circumstance, just turn off the power to prevent damaging the brake resistor.

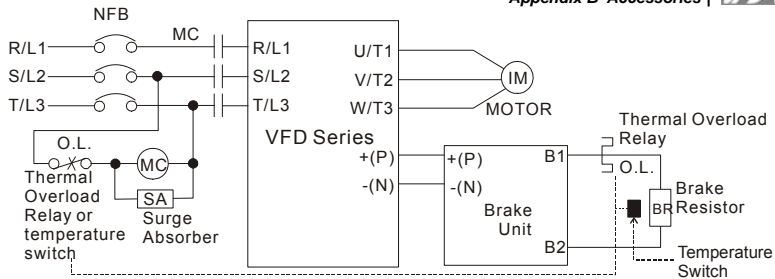

Note1: When using the AC drive with DC reactor, please refer to wiring diagram in the AC drive user manual for the wiring of terminal + (P) of Brake unit.

Note2: **Do NOT** wire terminal - (N) to the neutral point of power system.

- For model VFD110V43B, the brake unit is built-in. To increase the brake function, it can add optional brake unit.

B.1.1 Dimensions and Weights for Brake Resistors

(Dimensions are in millimeter)

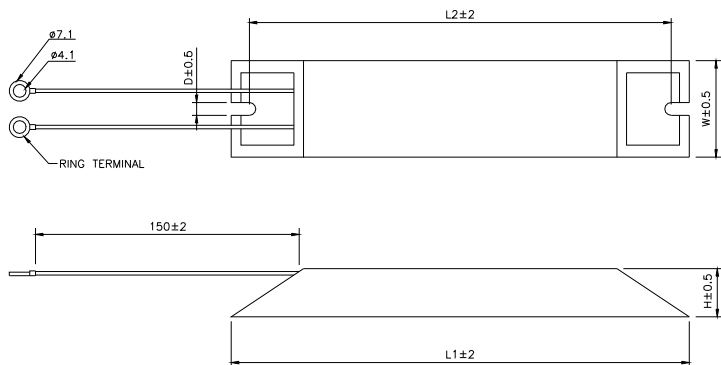
Order P/N: BR080W200, BR080W750, BR300W070, BR300W100, BR300W250, BR300W400, BR400W150, BR400W040

Model no.	L1	L2	H	D	W	Max. Weight (g)
BR080W200	140	125	20	5.3	60	160
BR080W750						
BR300W070	215	200	30	5.3	60	750
BR300W100						
BR300W250						
BR300W400						
BR400W150	265	250	30	5.3	60	930
BR400W040						

Order P/N: BR500W030, BR500W100, BR1KW020, BR1KW075

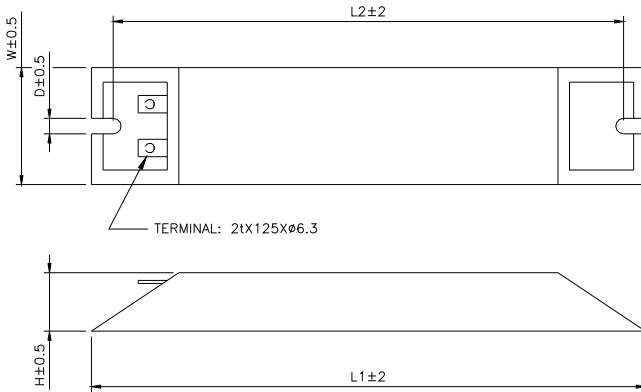

Model no.	L1	L2	H	D	W	Max. Weight (g)
BR500W030	335	320	30	5.3	60	1100
BR500W100						
BR1KW020	400	385	50	5.3	100	2800
BR1KW075						

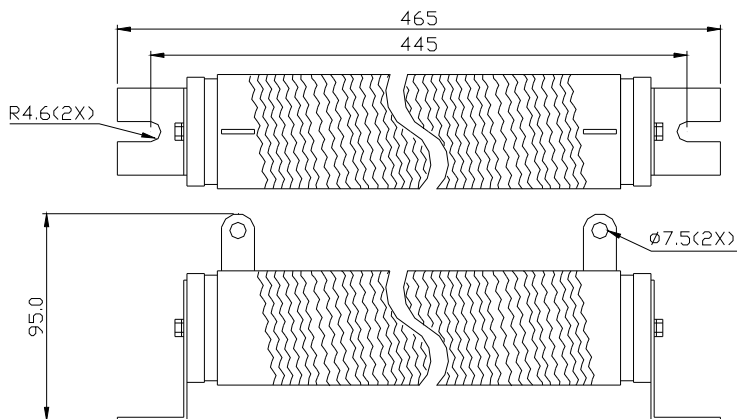

B.1.2 Specifications for Brake Unit

		230V Series		460V Series		
		2015	2022	4030	4045	4132
Max. Motor Power (kW)		15	22	30	45	132
Output Rating	Max. Peak Discharge Current (A) 10%ED	40	60	40	60	240
	Continuous Discharge Current (A)	15	20	15	18	75
	Brake Start-up Voltage (DC)	330/345/360/380/400/415±3V		660/690/720/760/800/830±6V		618/642/667/690/725/750±6V
Input Rating	DC Voltage	200~400VDC		400~800VDC		
Protection	Heat Sink Overheat	Temperature over +95°C (203 °F)				
	Alarm Output	Relay contact 5A 120VAC/28VDC (RA, RB, RC)				
	Power Charge Display	Blackout until bus (+~) voltage is below 50VDC				
Environment	Installation Location	Indoor (no corrosive gases, metallic dust)				
	Operating Temperature	-10°C ~ +50°C (14°F to 122°F)				
	Storage Temperature	-20°C ~ +60°C (-4°F to 140°F)				
	Humidity	90% Non-condensing				
	Vibration	9.8m/s ² (1G) under 20Hz 2m/s ² (0.2G) at 20~50Hz				
Wall-mounted Enclosed Type		IP50			IP10	

B.1.3 Dimensions for Brake Unit

(Dimensions are in millimeter[inch])

Figure 1: VFDB2015, VFDB2022, VFDB4030, VFDB4045

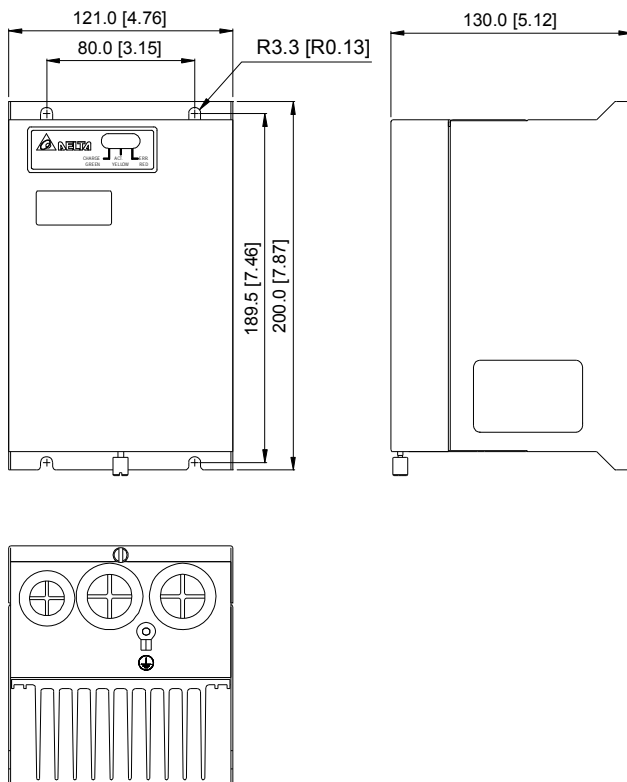
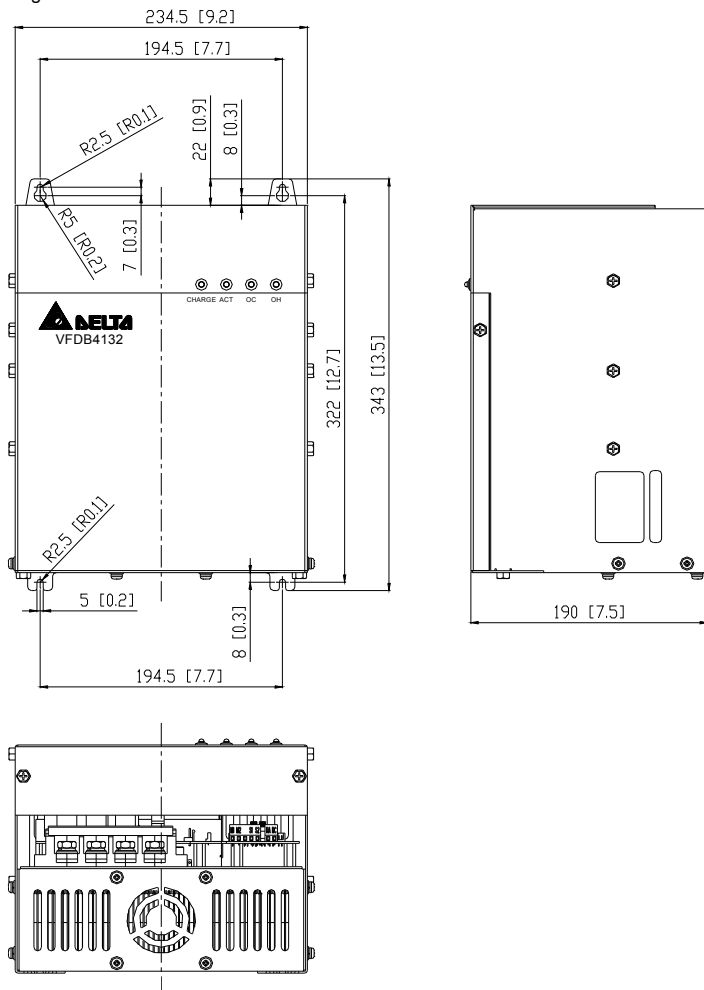

Figure 2: VFDB4132



B.2 No-fuse Circuit Breaker Chart

For 3-phase drives, the current rating of the breaker shall be within 2-4 times maximum input current rating.

(Refer to Appendix A for rated input current)

3-phase			
Model	Recommended no-fuse breaker (A)	Model	Recommended no-fuse breaker (A)
VFD007V23A-2	10	VFD110V43B-2	50
VFD007V43A-2	5	VFD150V23A-2	125
VFD015V23A-2	15	VFD150V43A-2	60
VFD015V43A-2	10	VFD185V23A-2	150
VFD022V23A-2	30	VFD185V43A-2	75
VFD022V43A-2	15	VFD220V23A-2	175
VFD037V23A-2	40	VFD220V43A-2	100
VFD037V43A-2	20	VFD300V23A-2	225
VFD055V23A-2	50	VFD300V43A-2	125
VFD055V43A-2	30	VFD370V23A-2	250
VFD075V23A-2	60	VFD370V43A-2	150
VFD075V43A-2	40	VFD450V43A-2	175
VFD110V23A-2	100	VFD550V43C-2	250
VFD110V43A-2	50	VFD750V43C-2	300

B.3 Fuse Specification Chart

Smaller fuses than those shown in the table are permitted.

Model	I (A) Input	I (A) Output	Line Fuse	
			I (A)	Bussmann P/N
VFD007V23A-2	5.7	5.0	10	JJN-10
VFD007V43A-2	3.2	2.7	5	JJN-6
VFD015V23A-2	7.6	7.0	15	JJN-15
VFD015V43A-2	4.3	4.2	10	JJN-10
VFD022V23A-2	15.5	11	30	JJN-30
VFD022V43A-2	5.9	5.5	15	JJN-15
VFD037V23A-2	20.6	17	40	JJN-40
VFD037V43A-2	11.2	8.5	20	JJN-20
VFD055V23A-2	26	25	50	JJN-50
VFD055V43A-2	14	13	30	JJN-30
VFD075V23A-2	34	33	60	JJN-60
VFD075V43A-2	19	18	40	JJN-40
VFD110V23A-2	50	49	100	JJN-100
VFD110V43A-2	25	24	50	JJN-50
VFD110V43B-2	25	24	50	JJN-50
VFD150V23A-2	60	65	125	JJN-125
VFD150V43A-2	32	32	60	JJN-60
VFD185V23A-2	75	75	150	JJN-150
VFD185V43A-2	39	38	75	JJN-70
VFD220V23A-2	90	90	175	JJN-175
VFD220V43A-2	49	45	100	JJN-100
VFD300V23A-2	110	120	225	JJN-225
VFD300V43A-2	60	60	125	JJN-125
VFD370V23A-2	142	145	250	JJN-250
VFD370V43A-2	63	73	150	JJN-150
VFD450V43A-2	90	91	175	JJN-175
VFD550V43C-2	130	110	250	JJN-250
VFD750V43C-2	160	150	300	JJN-300

B.4 AC Reactor

B.4.1 AC Input Reactor Recommended Value

460V, 50/60Hz, 3-Phase

kW	HP	Fundamental Amps	Max. continuous Amps	Inductance (mH)	
				3% impedance	5% impedance
0.75	1	4	6	9	12
1.5	2	4	6	6.5	9
2.2	3	8	12	5	7.5
3.7	5	8	12	3	5
5.5	7.5	12	18	2.5	4.2
7.5	10	18	27	1.5	2.5
11	15	25	37.5	1.2	2
15	20	35	52.5	0.8	1.2
18.5	25	35	52.5	0.8	1.2
22	30	45	67.5	0.7	1.2
30	40	55	82.5	0.5	0.85
37	50	80	120	0.4	0.7
45	60	80	120	0.4	0.7
55	75	100	150	0.3	0.45
75	100	130	195	0.2	0.3

B.4.2 AC Output Reactor Recommended Value

230V, 50/60Hz, 3-Phase

kW	HP	Fundamental Amps	Max. continuous Amps	Inductance (mH)	
				3% impedance	5% impedance
0.75	1	8	12	3	5
1.5	2	8	12	1.5	3
2.2	3	12	18	1.25	2.5
3.7	5	18	27	0.8	1.5
5.5	7.5	25	37.5	0.5	1.2
7.5	10	35	52.5	0.4	0.8
11	15	55	82.5	0.25	0.5
15	20	80	120	0.2	0.4

Appendix B Accessories | **VFD-VE**

kW	HP	Fundamental Amps	Max. continuous Amps	Inductance (mH)	
				3% impedance	5% impedance
18.5	25	80	120	0.2	0.4
22	30	100	150	0.15	0.3
30	40	130	195	0.1	0.2
37	50	160	240	0.075	0.15

460V, 50/60Hz, 3-Phase

kW	HP	Fundamental Amps	Max. continuous Amps	Inductance (mH)	
				3% impedance	5% impedance
0.75	1	4	6	9	12
1.5	2	4	6	6.5	9
2.2	3	8	12	5	7.5
3.7	5	12	18	2.5	4.2
5.5	7.5	18	27	1.5	2.5
7.5	10	18	27	1.5	2.5
11	15	25	37.5	1.2	2
15	20	35	52.5	0.8	1.2
18.5	25	45	67.5	0.7	1.2
22	30	45	67.5	0.7	1.2
30	40	80	120	0.4	0.7
37	50	80	120	0.4	0.7
45	60	100	150	0.3	0.45
55	75	130	195	0.2	0.3
75	100	160	240	0.15	0.23

B.4.3 Applications for AC Reactor

Connected in input circuit

Application 1	Question
When more than one AC motor drive is connected to the same power, one of them is ON during operation.	When applying to one of the AC motor drive, the charge current of capacity may cause voltage ripple. The AC motor drive may damage when over current occurs during operation.

Correct wiring

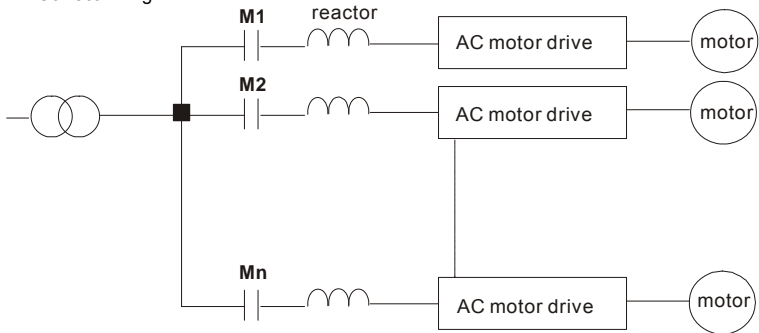

Application 2	Question
Silicon rectifier and AC motor drive is connected to the same power.	Surges will be generated at the instant of silicon rectifier switching on/off. These surges may damage the mains circuit.

Correct wiring

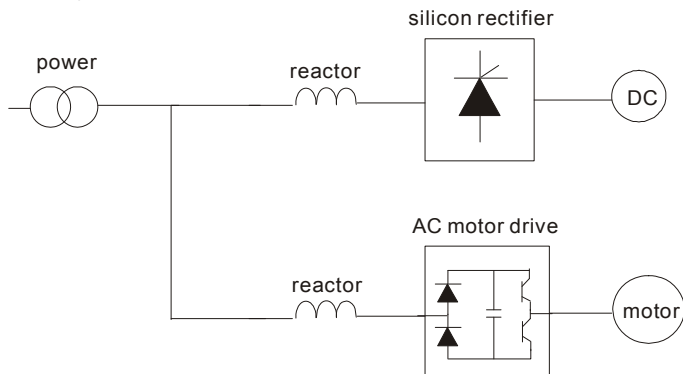

Application 3	Question
Used to improve the input power factor, to reduce harmonics and provide protection from AC line disturbances (surges, switching spikes, short interruptions, etc.). AC line reactor should be installed when the power supply capacity is 500kVA or more and exceeds 6 times the inverter capacity, or the mains wiring distance $\leq 10\text{m}$.	When power capacity is too large, line impedance will be small and the charge current will be too large. That may damage AC motor drive due to higher rectifier temperature.

Correct wiring

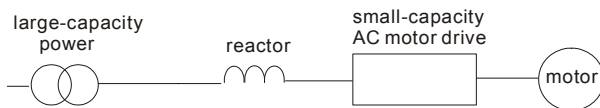

B.5 Zero Phase Reactor (RF220X00A)

Dimensions are in millimeter and (inch)

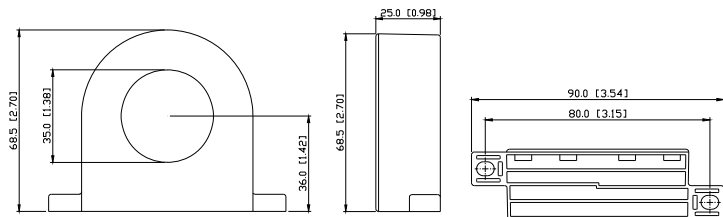

Cable type (Note)	Recommended Wire Size			Qty.	Wiring Method
	AWG	mm ²	Nominal (mm ²)		
Single-core	≤ 10	≤ 5.3	≤ 5.5	1	Diagram A
	≤ 2	≤ 33.6	≤ 38	4	Diagram B
Three-core	≤ 12	≤ 3.3	≤ 3.5	1	Diagram A
	≤ 1	≤ 42.4	≤ 50	4	Diagram B

Note: 600V Insulated unshielded Cable.

Diagram A

Please wind each wire 4 times around the core. The reactor must be put at inverter output as close as possible.

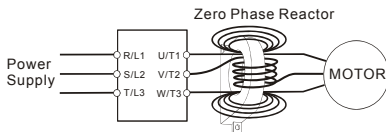
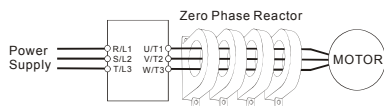

Diagram B

Please put all wires through 4 cores in series without winding.



Note 1: The table above gives approximate wire size for the zero phase reactors but the selection is ultimately governed by the type and diameter of cable fitted i.e. the cable must fit through the center hole of zero phase reactors.

Note 2: Only the phase conductors should pass through, not the earth core or screen.

Note 3: When long motor output cables are used an output zero phase reactor may be required to reduce radiated emissions from the cable.

B.6 DC Choke Recommended Values

230V DC Choke

Input voltage	kW	HP	DC Amps	Inductance (mh)
230Vac 50/60Hz 3-Phase	0.75	1	9	7.50
	1.5	2	12	4.00
	2.2	3	18	2.75
	3.7	5	25	1.75
	5.5	7.5	32	0.85
	7.5	10	40	0.75
	11	15	62	Built-in
	15	20	92	Built-in
	18.5	25	110	Built-in
	22	30	125	Built-in
	30	40	--	Built-in
	37	50	--	Built-in

460V DC Choke

Input voltage	kW	HP	DC Amps	Inductance (mh)
460Vac 50/60Hz 3-Phase	0.75	1	4	25.00
	1.5	2	9	11.50
	2.2	3	9	11.50
	3.7	5	12	6.00
	5.5	7.5	18	3.75
	7.5	10	25	4.00
	11	15	32	Built-in
	15	20	50	Built-in
	18.5	25	62	Built-in
	22	30	80	Built-in
	30	40	92	Built-in
	37	50	110	Built-in
	45	60	125	Built-in
	55	75	200	Built-in
75	100	240	Built-in	

B.7 Remote Controller RC-01

Dimensions are in millimeter

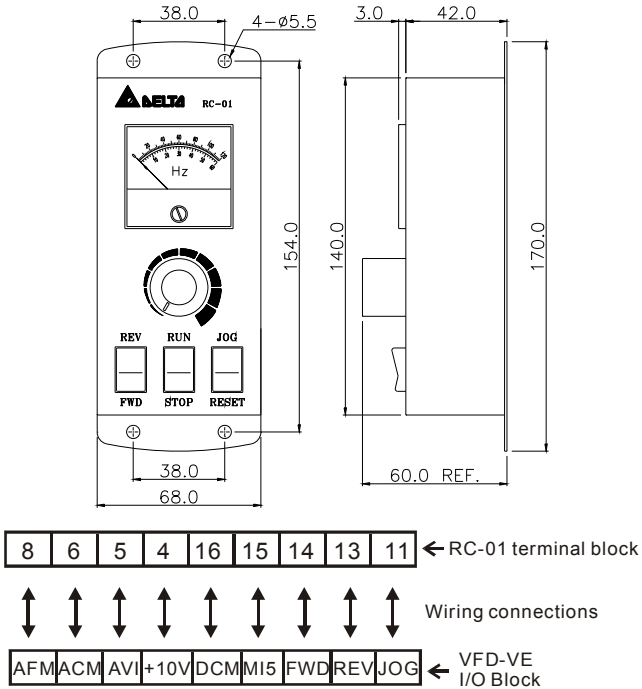

VFD-VE Programming:

Pr.00-20 set to 2

Pr.00-21 set to 1 (external controls)

Pr.02-00 set to 1 (setting Run/Stop and Fwd/Rev controls)

Pr.02-05 (MI5) set to 5 (External reset)

B.8 PG Card (for Encoder)

B.8.1 EMV-PG01X

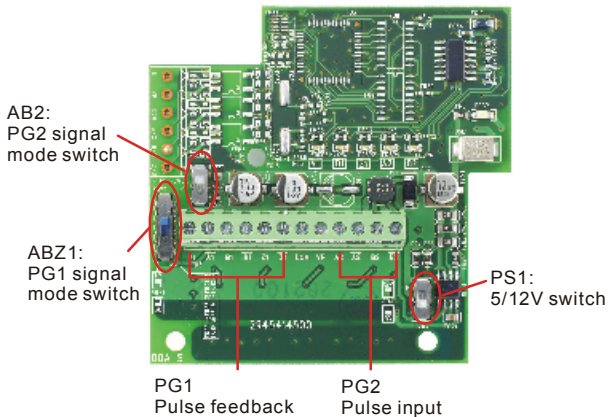

1. Terminals descriptions

Terminal Symbols	Descriptions
VP	Power source of EMV-PG01X (use PS1 to switch 12V/5V) Output Voltage: +5V/+12V±5% 200mA
DCM	Power source and input signal common
A1, $\overline{A1}$ B1, $\overline{B1}$ Z1, $\overline{Z1}$	Input signal. Input type is selected by ABZ1. It can be 1-phase or 2-phase input. Maximum 300kP/sec
A2, $\overline{A2}$ B2, $\overline{B2}$	Input signal. Input type is selected by AB2. It can be 1-phase or 2-phase input. Maximum 300kP/sec
⊕	Grounding

2. Wiring Notes

- a. Please use a shielded cable to prevent interference. Do not run control wires parallel to any high voltage AC power line (200 V and above).
- b. Recommended wire size 0.21 to 0.81mm² (AWG24 to AWG18).

3. Wire length (wire length and signal frequency are in inverse proportion)

Types of Pulse Generators	Maximum Wire Length	Wire Gauge
Output Voltage	50m	1.25mm ² (AWG16) or above
Open Collector	50m	
Line Driver	300m	
Complementary	70m	

4. Basic Wiring Diagram

wiring 1

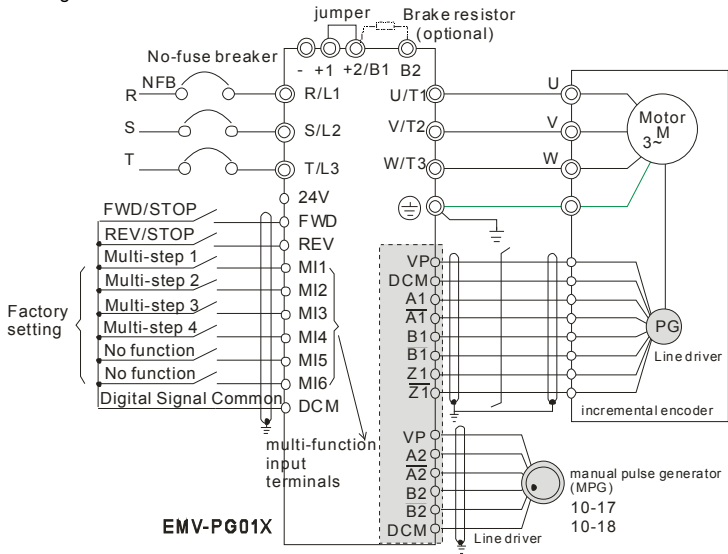

wiring 2

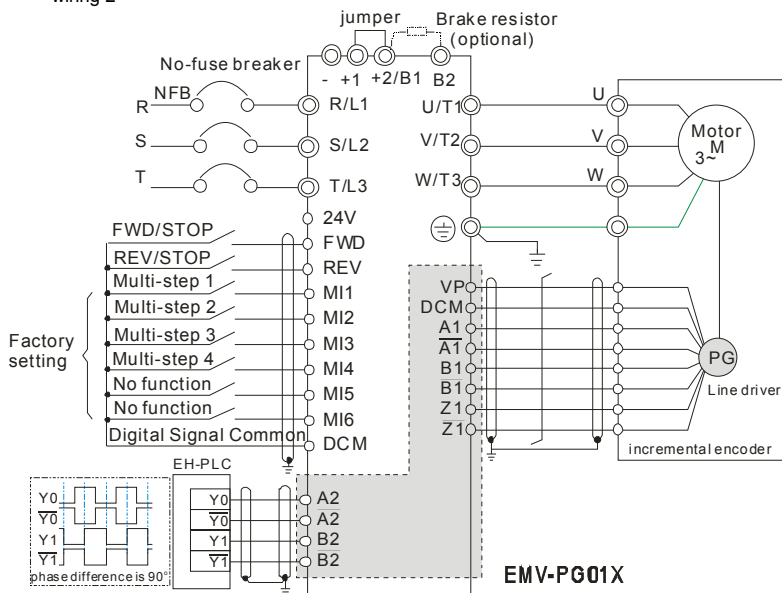

Example:

It is recommended to set it in TP mode when VFD-VE series inputs the pulse, i.e. inputs pulse from PLC or host controller into the A2, /A2, B2 and /B2 on the PG card of AC motor drive to prevent the signal received interference (if using input signal with open collector, please use the external power (such as PLC power) with a pull-high resistor).

The best wiring:

Applicable models:
EMV-PG01X
EMV-PG01O
EMV-PG01L

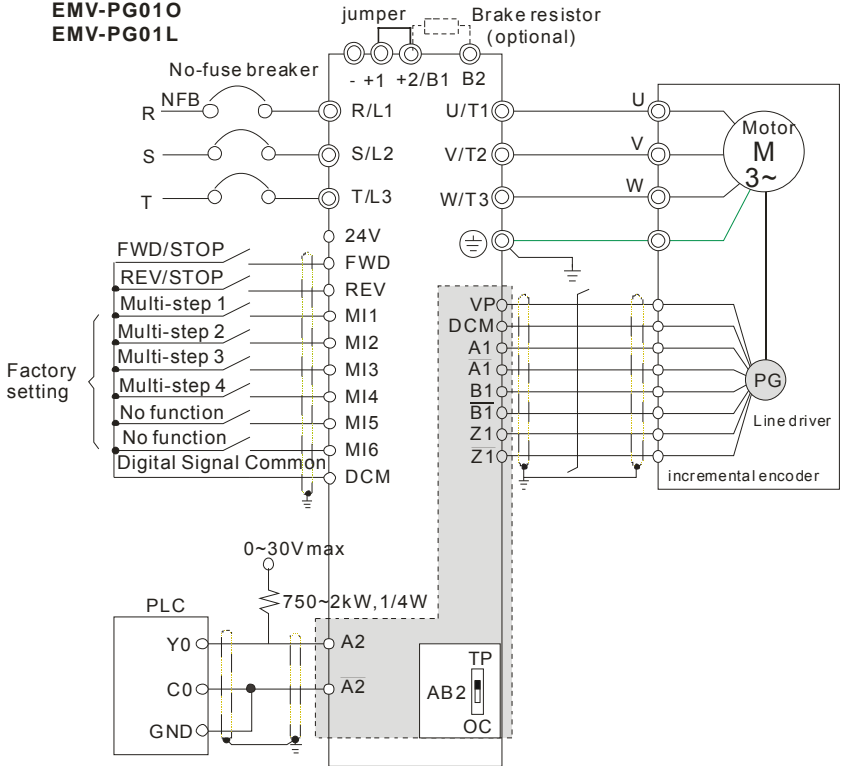

5. Types of Pulse Generators (Encoders)

Types of Pulse Generators	ABZ1+ PS1		AB2+PS1	
	5V	12V	5V	12V
<p>VOLTAGE</p>				

Types of Pulse Generators	ABZ1+ PS1		AB2+PS1	
	5V	12V	5V	12V
<p>Open collector</p>				
<p>Line driver</p>				
<p>Complementary</p>				

B.8.2 EMV-PG010

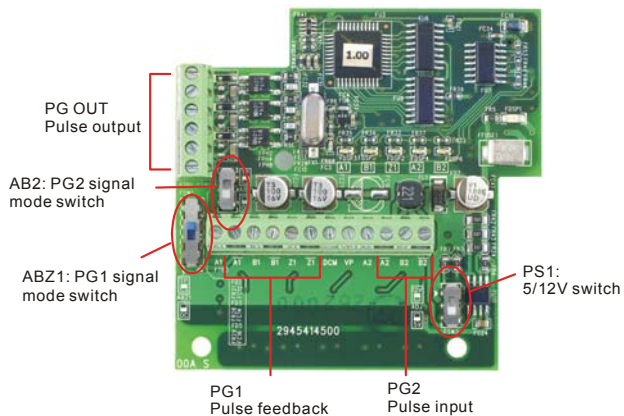

1. Terminals descriptions

Terminal Symbols	Descriptions
VP	Power source of EMV-PG010 (use PS1 to switch 12V/5V) Output Voltage: +5V/+12V±5% 200mA
DCM	Power source and input signal common
A1, $\overline{A1}$ B1, $\overline{B1}$ Z1, $\overline{Z1}$	Input signal from encoder. Input type is selected by ABZ1. It can be 1-phase or 2-phase input. Maximum 300kP/sec
A2, $\overline{A2}$ B2, $\overline{B2}$	Input signal from encoder. Input type is selected by AB2. It can be 1-phase or 2-phase input. Maximum 300kP/sec
A/O, B/O, Z/O	Output signal. It has division frequency function (Pr.10-16), open collector: max. output DC20V 50mA
	Grounding

2. Wiring Notes

- a. Please use a shielded cable to prevent interference. Do not run control wires parallel to any high voltage AC power line (200 V and above).
- b. Recommended wire size 0.21 to 0.81mm² (AWG24 to AWG18).

3. Wire length: (wire length and signal frequency are in inverse proportion)

Types of Pulse Generators	Maximum Wire Length	Wire Gauge
Output Voltage	50m	1.25mm ² (AWG16) or above
Open Collector	50m	
Line Driver	300m	
Complementary	70m	

4. Basic Wiring Diagram

wiring 1

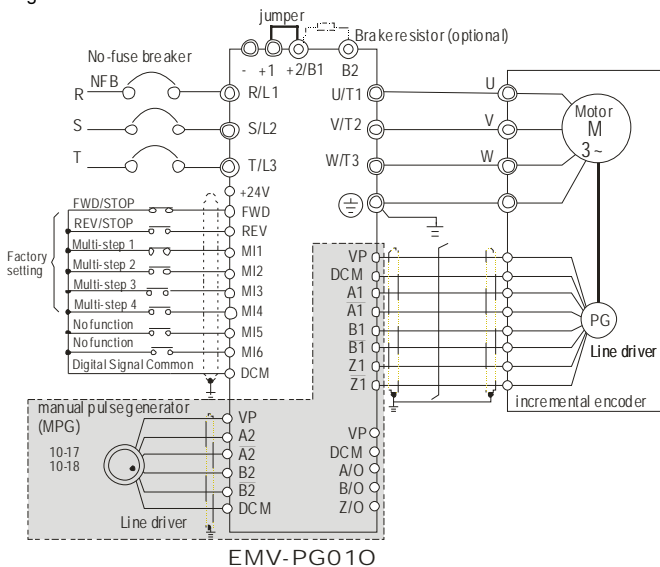



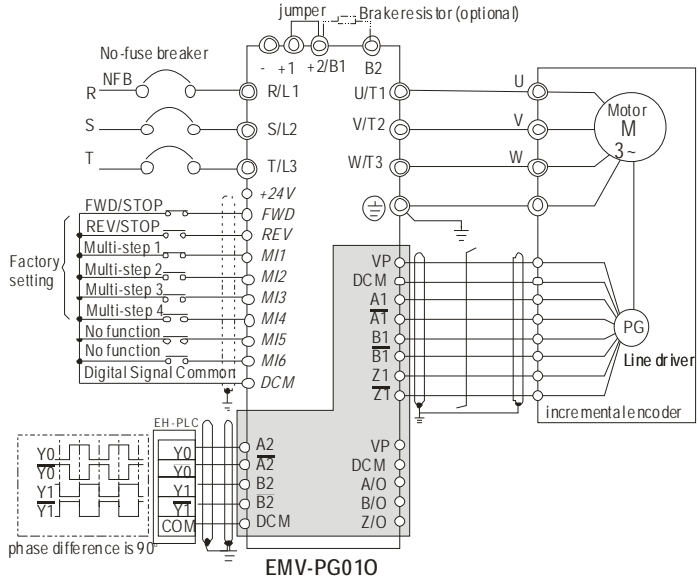



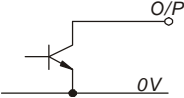
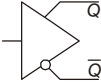

wiring 2

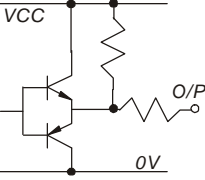

5. Types of Pulse Generators (Encoders)

Types of Pulse Generators	ABZ1+PS1		AB2+PS1	
	5V	12V	5V	12V
<p>VOLTAGE</p>				
Open collector				

<p>VCC</p> 				
<p>Line driver</p> 				
<p>Complementary</p> 				

B.8.3 EMV-PG01L

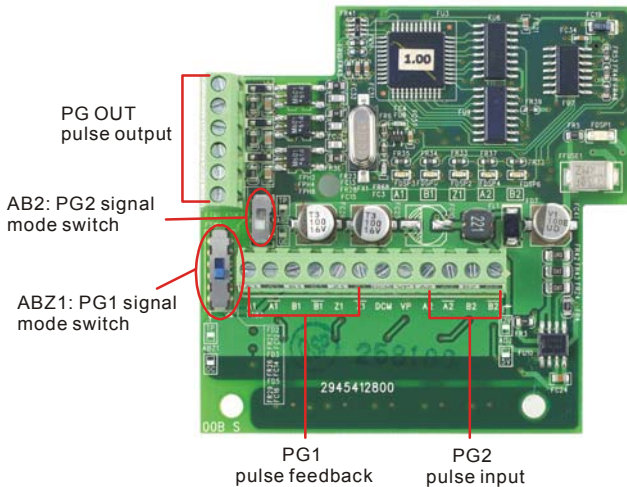

1. Terminals descriptions

Terminal Symbols	Descriptions
VP	Power source of EMV-PG01L Output Voltage: +5V±5% 200mA
DCM	Power source and input signal common
A1, $\overline{A1}$ B1, $\overline{B1}$ Z1, $\overline{Z1}$	Input signal. Input type is selected by ABZ1. It can be 1-phase or 2-phase input. Maximum 300kP/sec
A2, $\overline{A2}$ B2, $\overline{B2}$	Input signal. Input type is selected by AB2. It can be 1-phase or 2-phase input. Maximum 300kP/sec
A/O, B/O, Z/O	Output signal. It has division frequency function (Pr.10-16), Line driver: max. output DC5V 50mA
\oplus	Grounding

2. Wiring Notes

- a. Please use a shielded cable to prevent interference. Do not run control wires parallel to any high voltage AC power line (200 V and above).

b. Recommended wire size 0.21 to 0.81mm² (AWG24 to AWG18).

3. Wire length: (wire length and signal frequency are in inverse proportion)

Types of Pulse Generators	Maximum Wire Length	Wire Gauge
Output Voltage	50m	1.25mm ² (AWG16) or above
Open Collector	50m	
Line Driver	300m	
Complementary	70m	

4. Basic Wiring Diagram

wiring 1

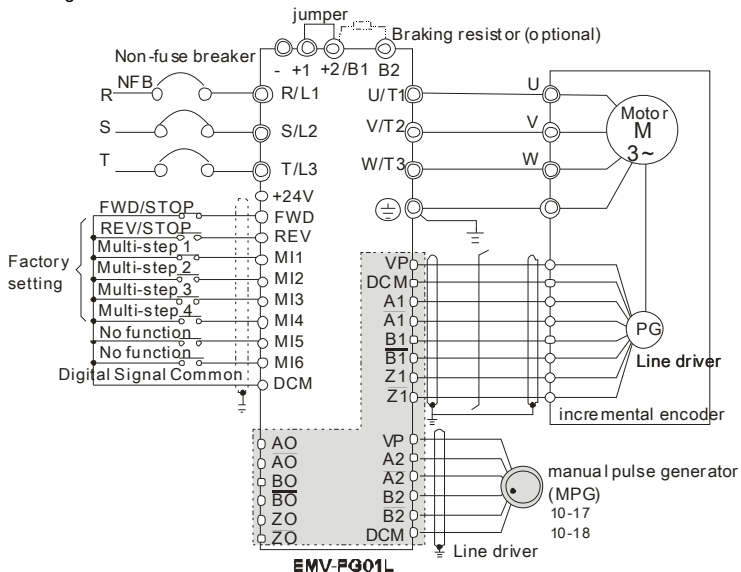



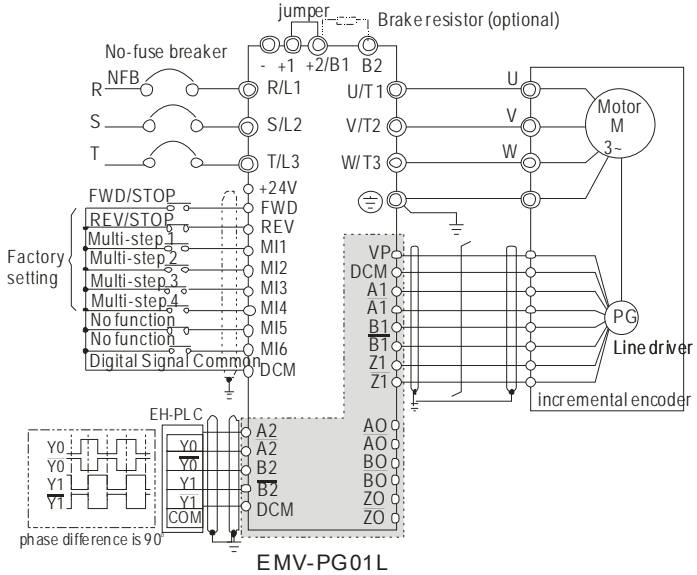

wiring 2

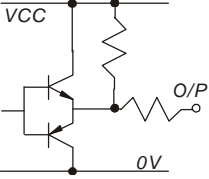

5. Types of Pulse Generators (Encoders)

Types of Pulse Generators	ABZ1	AB2
	5V	5V
<p>VOLTAGE</p>		
<p>Open collector</p>		

Types of Pulse Generators	ABZ1	AB2
	5V	5V
<p>Line driver</p> 		
<p>Complementary</p> 		

B.9 AMD-EMI Filter Cross Reference

AC Drives	Model Number	FootPrint
VFD007V43A-2, VFD015V43A-2, VFD022V43A-2	RF022B43AA	Y
VFD037V43A-2	RF037B43BA	Y
VFD055V43A-2, VFD075V43A-2, VFD110V43A-2, VFD110V43B-2	RF110B43CA	Y
VFD007V23A-2, VFD015V23A-2	10TDT1W4C	N
VFD022V23A-2, VFD037V23A-2	26TDT1W4C	N
VFD055V23A-2, VFD075V23A-2, VFD150V43A-2, VFD185V43A-2	50TDS4W4C	N
VFD110V23A-2, VFD150V23A-2, VFD220V43A-2, VFD300V43A-2, VFD370V43A-2	100TDS84C	N
VFD550V43A-2, VFD750V43A-2, VFD550V43C-2, VFD750V43C-2	200TDDS84C	N
VFD185V23A-2, VFD220V23A-2, VFD300V23A-2, VFD450V43A-2	150TDS84C	N
VFD370V23A-2	180TDS84C	N

Installation

All electrical equipment, including AC motor drives, will generate high-frequency/low-frequency noise and will interfere with peripheral equipment by radiation or conduction when in operation. By using an EMI filter with correct installation, much interference can be eliminated. It is recommended to use DELTA EMI filter to have the best interference elimination performance.

We assure that it can comply with following rules when AC motor drive and EMI filter are installed and wired according to user manual:

- **EN61000-6-4**
- **EN61800-3: 1996 + A11: 2000**
- **EN55011 (1991) Class A Group 1 (1st Environment, restricted distribution)**

General precaution

1. EMI filter and AC motor drive should be installed on the same metal plate.
2. Please install AC motor drive on footprint EMI filter or install EMI filter as close as possible to the AC motor drive.
3. Please wire as short as possible.

4. Metal plate should be grounded.
5. The cover of EMI filter and AC motor drive or grounding should be fixed on the metal plate and the contact area should be as large as possible.

Choose suitable motor cable and precautions

Improper installation and choice of motor cable will affect the performance of EMI filter. Be sure to observe the following precautions when selecting motor cable.

1. Use the cable with shielding (double shielding is the best).
2. The shielding on both ends of the motor cable should be grounded with the minimum length and maximum contact area.
3. Remove any paint on metal saddle for good ground contact with the plate and shielding.

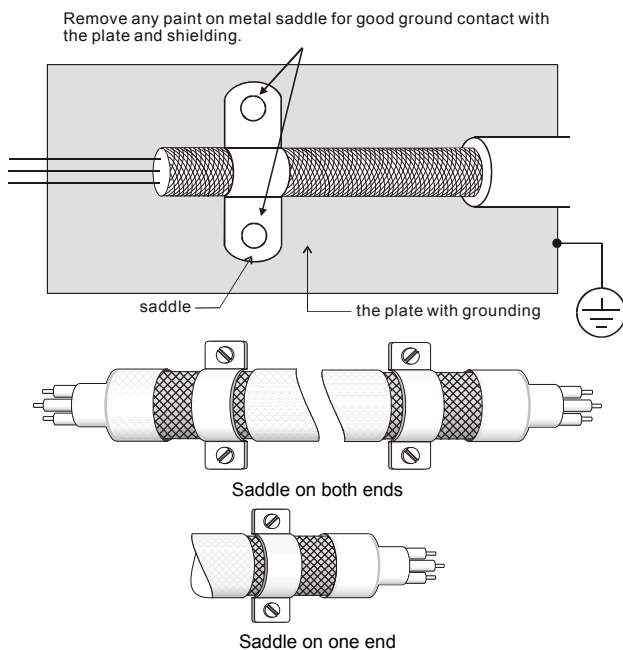

The length of motor cable

When motor is driven by an AC motor drive of PWM type, the motor terminals will experience surge voltages easily due to components conversion of AC motor drive and cable capacitance. When the motor cable is very long (especially for the 460V series), surge voltages may reduce insulation quality. To prevent this situation, please follow the rules below:

- Use a motor with enhanced insulation.
- Connect an output reactor (optional) to the output terminals of the AC motor drive
- The length of the cable between AC motor drive and motor should be as short as possible (10 to 20 m or less)
- For models 7.5hp/5.5kW and above:

Insulation level of motor	1000V	1300V	1600V
460VAC input voltage	66 ft (20m)	328 ft (100m)	1312 ft (400m)
230VAC input voltage	1312 ft (400m)	1312 ft (400m)	1312 ft (400m)

- For models 5hp/3.7kW and less:

Insulation level of motor	1000V	1300V	1600V
460VAC input voltage	66 ft (20m)	165 ft (50m)	165 ft (50m)
230VAC input voltage	328 ft (100m)	328 ft (100m)	328 ft (100m)

**NOTE**

When a thermal O/L relay protected by motor is used between AC motor drive and motor, it may malfunction (especially for 460V series), even if the length of motor cable is only 165 ft (50m) or less. To prevent it, please use AC reactor and/or lower the carrier frequency (Pr. 00-17 PWM carrier frequency).

**NOTE**

Never connect phase lead capacitors or surge absorbers to the output terminals of the AC motor drive.

- If the length is too long, the stray capacitance between cables will increase and may cause leakage current. It will activate the protection of over current, increase leakage current or not insure the correction of current display. The worst case is that AC motor drive may damage.
- If more than one motor is connected to the AC motor drive, the total wiring length is the sum of the wiring length from AC motor drive to each motor.

B.9.1 Dimensions

Dimensions are in millimeter and (inch)

Order P/N: RF015B21AA / RF022B43AA

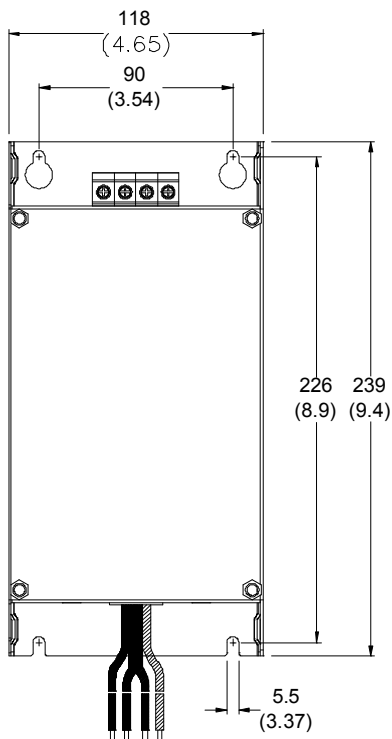
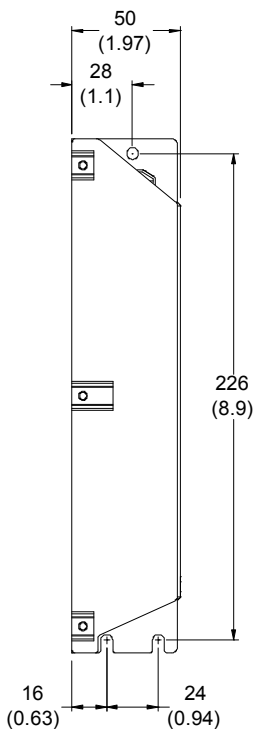
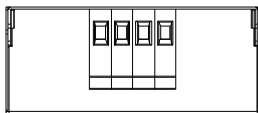

Order P/N: RF022B21BA / RF037B43BA

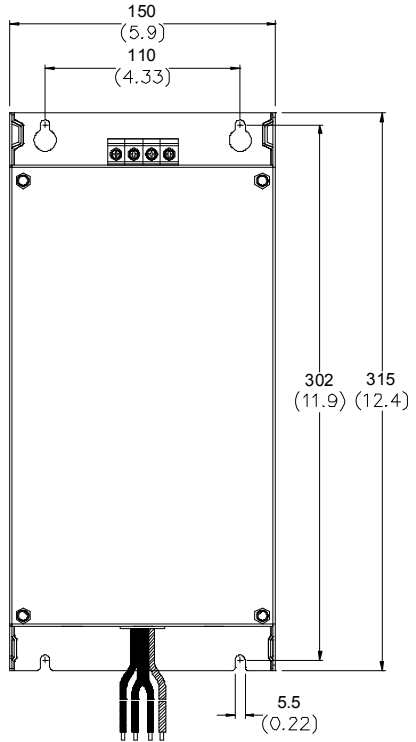
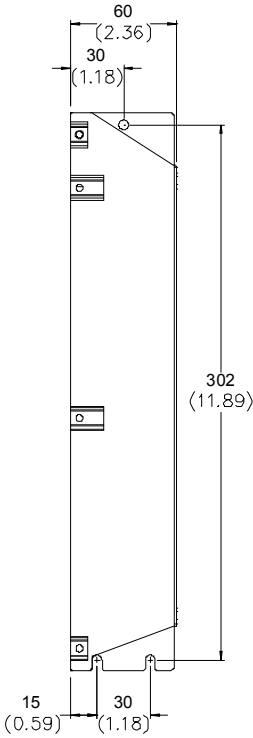
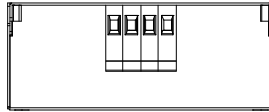

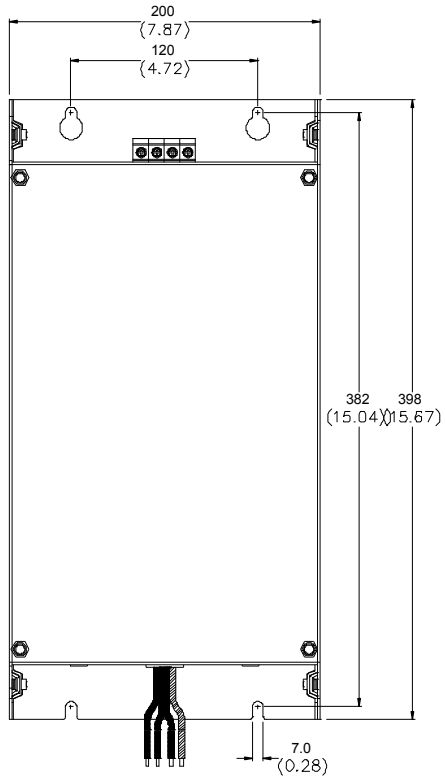
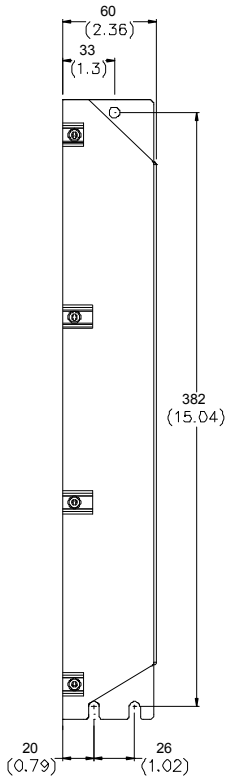
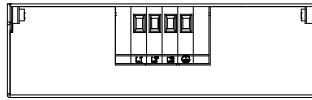

Order P/N: 10TDT1W4C

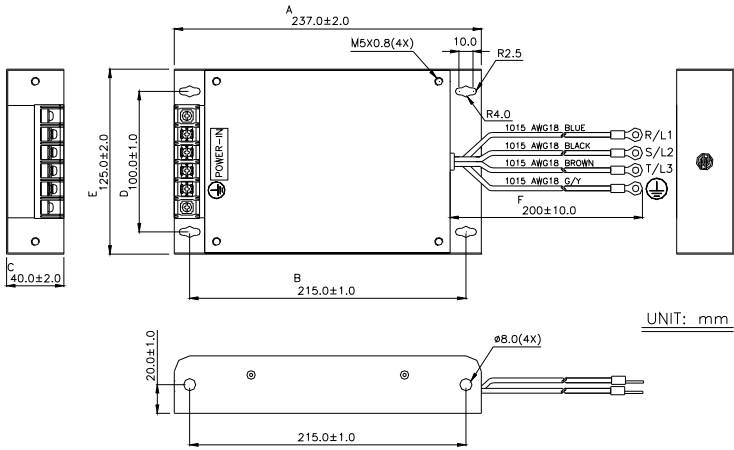

Order P/N: 26TDT1W4C

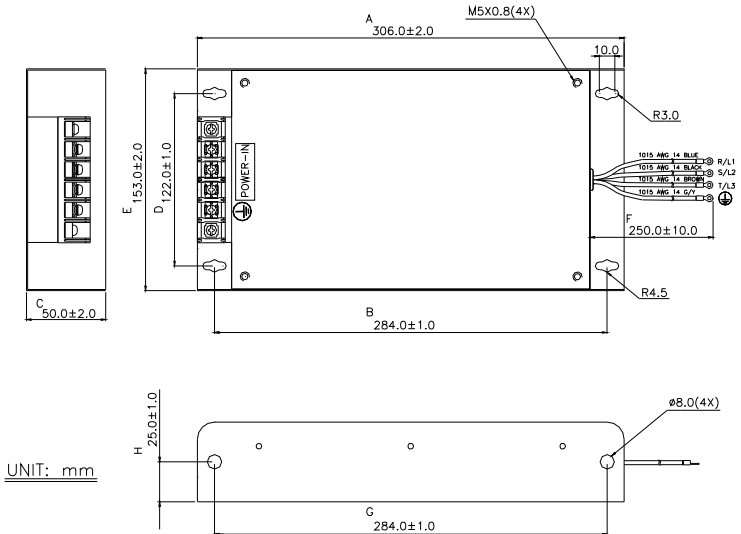

Order P/N: 50TDS4W4C

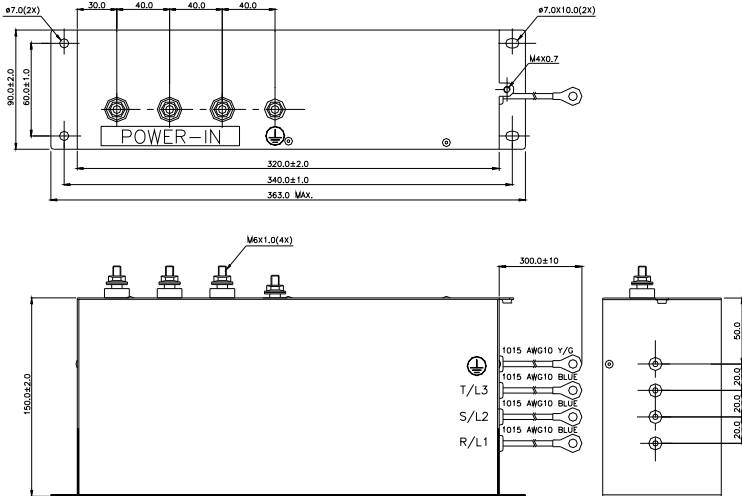

Order P/N: 100TDS84C

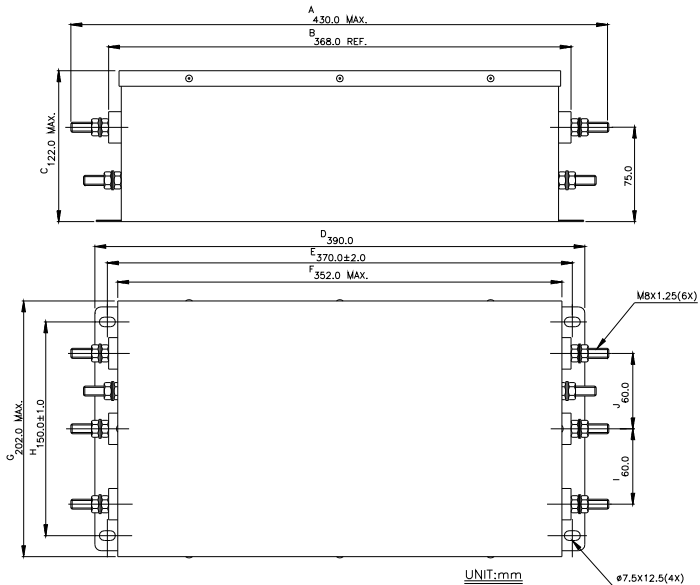

Order P/N: 200TDDS84C

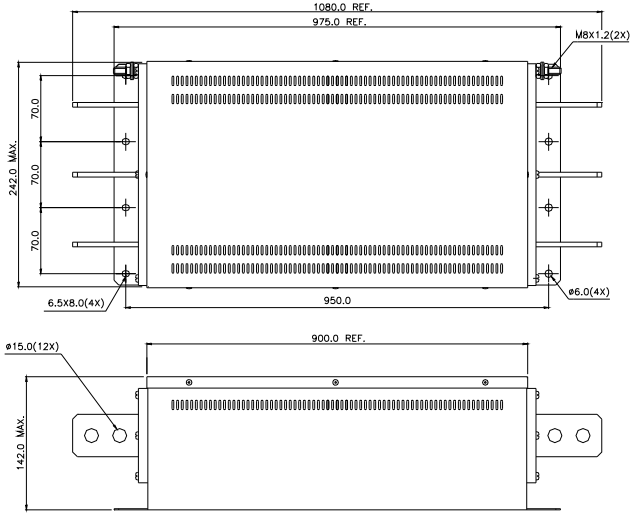

Order P/N: 150TDS84C

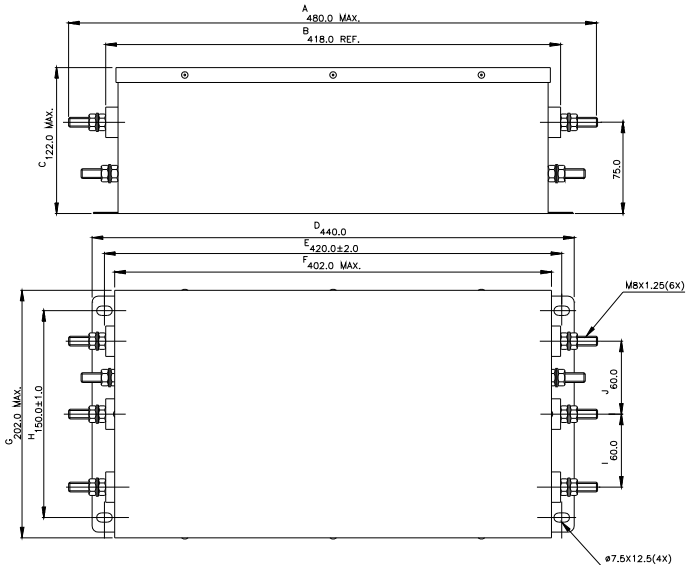

Order P/N: 180TDS84C

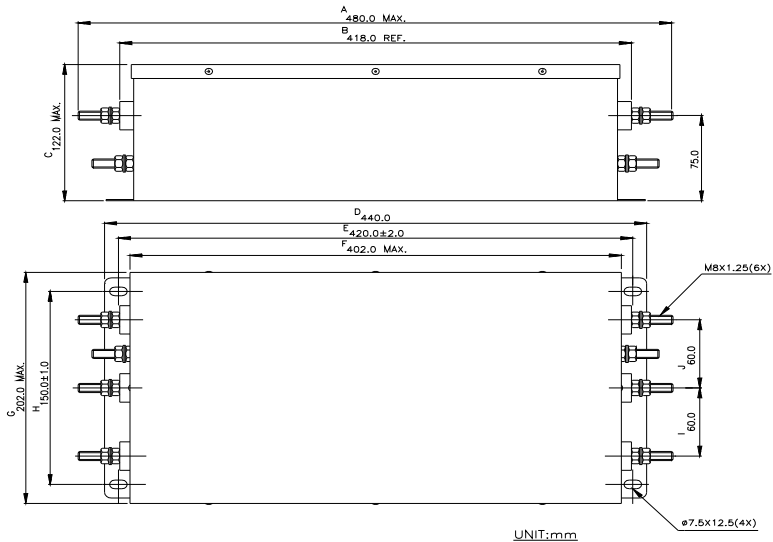

B.10 Multi-function I/O Extension Card

B.10.1 Functions

EMV-APP01 optional multi-function I/O extension card is exclusively designed for VFD-VE series and used with firmware version 2.04 and above. It communicates with the AC motor drive by RS-485 communication port (COM1). To make sure that the communication is normal, it needs to set the COM1 communication protocol to RTU mode (8, N, 1), i.e. set Pr.09-04 to 12 no matter what the baud rate switch is set.

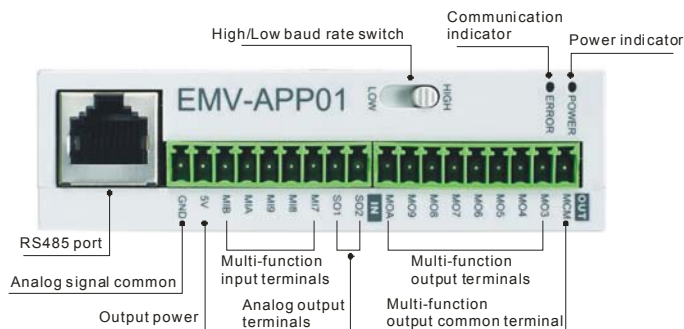



NOTE

Please operate by the following steps for switching the high/low baud rate,

1. make sure that RS-485 cable is disconnected before operation
2. switch the high/low baud rate
3. set Pr.09-01 to the corresponding baud rate to finish setting

If the RS-485 cable is connected before changing the high/low baud rate, the communication function will still be invalid even if the communication baud rate (Pr.09-01) is changed to the corresponding baud rate and the ERROR indicator is normal.

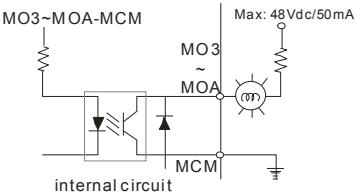
Terminals	Description
POWER	Power indicator. It will be ON when EMV-APP01 connects to the AC motor drive correctly.
ERROR	ERROR indicator. It will be ON when EMV-APP01 can communicate with the AC motor drive or it will blink.
HIGH/LOW	Baud rate switch for extension card: HIGH: set the baud rate to 115200 LOW: set the baud rate to 9600

Terminals	Description
5V	Output power 500mA Max
GND	<p>Analog signal common terminal</p> <p> NOTE</p> <p>This GND terminal is only used for 5V terminal on EMV-APP01. Please do NOT confuse with DCM terminal.</p>
SO1-MCM SO2-MCM	<p>Multi-function analog voltage output terminal 0~10.0V (output current: 2mA Max.)</p> <p>Analog output is set by Pr.03-21 and Pr.03-24.</p>
MI7~MIB	<p>Multi-function input terminals</p> <p>Please refer to Pr.02-23 to Pr.02-27 for MI7-GND~MIB-GND function selection. Take terminals MI7-GND for example, ON: the activation current is 6.5mA and OFF: leakage current tolerance is 10μA.</p>
MO3~MOA	<p>Multi-function output terminals (photocoupler)</p> <p>The AC motor drive outputs each monitor signal, such as during operation, frequency attained and overload, by transistor with open collector. Please refer to Pr.03-35 to Pr.03-42 for details.</p> 
MCM	<p>Multi-function output common terminal. Max: 48Vdc/50mA</p> <p> NOTE</p> <p>This MCM terminal is only used with MO3~MOA on EMV-APP01. Please do NOT confuse with terminal MCM.</p>

Appendix C How to Select the Right AC Motor Drive

The choice of the right AC motor drive for the application is very important and has great influence on its lifetime. If the capacity of AC motor drive is too large, it cannot offer complete protection to the motor and motor maybe damaged. If the capacity of AC motor drive is too small, it cannot offer the required performance and the AC motor drive maybe damaged due to overloading.

But by simply selecting the AC motor drive of the same capacity as the motor, user application requirements cannot be met completely. Therefore, a designer should consider all the conditions, including load type, load speed, load characteristic, operation method, rated output, rated speed, power and the change of load capacity. The following table lists the factors you need to consider, depending on your requirements.

Item		Related Specification			
		Speed and torque characteristics	Time ratings	Overload capacity	Starting torque
Load type	Friction load and weight load				
	Liquid (viscous) load Inertia load Load with power transmission	●			●
Load speed and torque characteristics	Constant torque	●			
	Constant output Decreasing torque Decreasing output		●		
Load characteristics	Constant load				
	Shock load	●		●	●
	Repetitive load	●	●	●	●
	High starting torque Low starting torque				
Continuous operation, Short-time operation Long-time operation at medium/low speeds			●	●	
Maximum output current (instantaneous) Constant output current (continuous)		●		●	
Maximum frequency, Base frequency		●			
Power supply transformer capacity or percentage impedance Voltage fluctuations and unbalance Number of phases, single phase protection Frequency				●	●
Mechanical friction, losses in wiring				●	●
Duty cycle modification			●		

C.1 Capacity Formulas

1. When one AC motor drive operates one motor

The starting capacity should be less than 1.5x rated capacity of AC motor drive

The starting capacity=

$$\frac{k \times N}{973 \times \eta \times \cos \varphi} \left(T_L + \frac{GD^2}{375} \times \frac{N}{t_A} \right) \leq 1.5 \times \text{the_capacity_of_AC_motor_drive(kVA)}$$

2. When one AC motor drive operates more than one motor

2.1 The starting capacity should be less than the rated capacity of AC motor drive

- Acceleration time ≤ 60 seconds

The starting capacity=

$$\frac{k \times N}{\eta \times \cos \varphi} [n_r + n_s(k_s - 1)] = P_{Cl} \left[1 + \frac{n_r}{n_r} (k_s - 1) \right] \leq 1.5 \times \text{the_capacity_of_AC_motor_drive(kVA)}$$

- Acceleration time ≥ 60 seconds

The starting capacity=

$$\frac{k \times N}{\eta \times \cos \varphi} [n_r + n_s(k_s - 1)] = P_{Cl} \left[1 + \frac{n_r}{n_r} (k_s - 1) \right] \leq \text{the_capacity_of_AC_motor_drive(kVA)}$$

2.2 The current should be less than the rated current of AC motor drive(A)

- Acceleration time ≤ 60 seconds

$$n_r + I_M \left[1 + \frac{n_s}{n_r} (k_s - 1) \right] \leq 1.5 \times \text{the_rated_current_of_AC_motor_drive(A)}$$

- Acceleration time ≥ 60 seconds

$$n_r + I_M \left[1 + \frac{n_s}{n_r} (k_s - 1) \right] \leq \text{the_rated_current_of_AC_motor_drive(A)}$$

2.3 When it is running continuously

- The requirement of load capacity should be less than the capacity of AC motor drive(kVA)
The requirement of load capacity=

$$\frac{k \times P_M}{\eta \times \cos \varphi} \leq \text{the_capacity_of_AC_motor_drive(kVA)}$$

- The motor capacity should be less than the capacity of AC motor drive

$$k \times \sqrt{3} \times V_M \times I_M \times 10^{-3} \leq \text{the_capacity_of_AC_motor_drive(kVA)}$$

- The current should be less than the rated current of AC motor drive(A)

$$k \times I_M \leq \text{the_rated_current_of_AC_motor_drive(A)}$$

Symbol explanation

P_M	: Motor shaft output for load (kW)
η	: Motor efficiency (normally, approx. 0.85)
$\cos \varphi$: Motor power factor (normally, approx. 0.75)
V_M	: Motor rated voltage(V)
I_M	: Motor rated current(A), for commercial power
k	: Correction factor calculated from current distortion factor (1.05-1.1, depending on PWM method)
P_{C1}	: Continuous motor capacity (kVA)
k_S	: Starting current/rated current of motor
n_T	: Number of motors in parallel
n_S	: Number of simultaneously started motors
GD^2	: Total inertia (GD^2) calculated back to motor shaft (kg m^2)
T_L	: Load torque
t_A	: Motor acceleration time
N	: Motor speed

C.2 General Precaution

Selection Note

1. When the AC Motor Drive is connected directly to a large-capacity power transformer (600kVA or above) or when a phase lead capacitor is switched, excess peak currents may occur in the power input circuit and the converter section may be damaged. To avoid this, use an AC input reactor (optional) before AC Motor Drive mains input to reduce the current and improve the input power efficiency.
2. When a special motor is used or more than one motor is driven in parallel with a single AC Motor Drive, select the AC Motor Drive current $\geq 1.25 \times (\text{Sum of the motor rated currents})$.
3. The starting and accel./decel. characteristics of a motor are limited by the rated current and the overload protection of the AC Motor Drive. Compared to running the motor D.O.L. (Direct On-Line), a lower starting torque output with AC Motor Drive can be expected. If higher starting torque is required (such as for elevators, mixers, tooling machines, etc.) use an AC Motor Drive of higher capacity or increase the capacities for both the motor and the AC Motor Drive.
4. When an error occurs on the drive, a protective circuit will be activated and the AC Motor Drive output is turned off. Then the motor will coast to stop. For an emergency stop, an external mechanical brake is needed to quickly stop the motor.

Parameter Settings Note

1. The AC Motor Drive can be driven at an output frequency up to 400Hz (less for some models) with the digital keypad. Setting errors may create a dangerous situation. For safety, the use of the upper limit frequency function is strongly recommended.
2. High DC brake operating voltages and long operation time (at low frequencies) may cause overheating of the motor. In that case, forced external motor cooling is recommended.
3. Motor accel./decel. time is determined by motor rated torque, load torque, and load inertia.
4. If the stall prevention function is activated, the accel./decel. time is automatically extended to a length that the AC Motor Drive can handle. If the motor needs to decelerate within a

certain time with high load inertia that can't be handled by the AC Motor Drive in the required time, either use an external brake resistor and/or brake unit, depending on the model, (to shorten deceleration time only) or increase the capacity for both the motor and the AC Motor Drive.

C.3 How to Choose a Suitable Motor

Standard motor

When using the AC Motor Drive to operate a standard 3-phase induction motor, take the following precautions:

1. The energy loss is greater than for an inverter duty motor.
2. Avoid running motor at low speed for a long time. Under this condition, the motor temperature may rise above the motor rating due to limited airflow produced by the motor's fan. Consider external forced motor cooling.
3. When the standard motor operates at low speed for long time, the output load must be decreased.
4. The load tolerance of a standard motor is as follows:

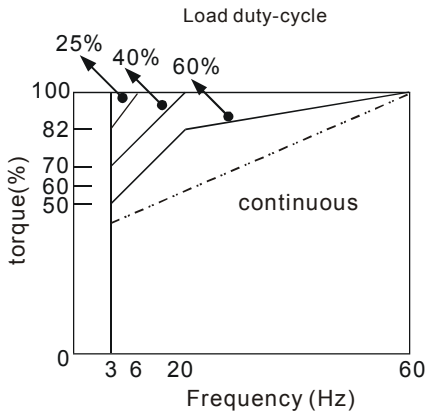

5. If 100% continuous torque is required at low speed, it may be necessary to use a special inverter duty motor.
6. Motor dynamic balance and rotor endurance should be considered once the operating speed exceeds the rated speed (60Hz) of a standard motor.

7. Motor torque characteristics vary when an AC Motor Drive instead of commercial power supply drives the motor. Check the load torque characteristics of the machine to be connected.
8. Because of the high carrier frequency PWM control of the VFD series, pay attention to the following motor vibration problems:
 - *Resonant mechanical vibration: anti-vibration (damping) rubbers should be used to mount equipment that runs at varying speed.*
 - *Motor imbalance: special care is required for operation at 50 or 60 Hz and higher frequency.*
 - *To avoid resonances, use the Skip frequencies.*
9. The motor fan will be very noisy when the motor speed exceeds 50 or 60Hz.

Special motors:

1. Pole-changing (Dahlander) motor:

The rated current is differs from that of a standard motor. Please check before operation and select the capacity of the AC motor drive carefully. When changing the pole number the motor needs to be stopped first. If over current occurs during operation or regenerative voltage is too high, please let the motor free run to stop (coast).
2. Submersible motor:

The rated current is higher than that of a standard motor. Please check before operation and choose the capacity of the AC motor drive carefully. With long motor cable between AC motor drive and motor, available motor torque is reduced.
3. Explosion-proof (Ex) motor:

Needs to be installed in a safe place and the wiring should comply with the (Ex) requirements. Delta AC Motor Drives are not suitable for (Ex) areas with special precautions.
4. Gear reduction motor:

The lubricating method of reduction gearbox and speed range for continuous operation will be different and depending on brand. The lubricating function for operating long time at low speed and for high-speed operation needs to be considered carefully.
5. Synchronous motor:

The rated current and starting current are higher than for standard motors. Please check before operation and choose the capacity of the AC motor drive carefully. When the AC

motor drive operates more than one motor, please pay attention to starting and changing the motor.

Power Transmission Mechanism

Pay attention to reduced lubrication when operating gear reduction motors, gearboxes, belts and chains, etc. over longer periods at low speeds. At high speeds of 50/60Hz and above, lifetime reducing noises and vibrations may occur.

Motor torque

The torque characteristics of a motor operated by an AC motor drive and commercial mains power are different.

Below you'll find the torque-speed characteristics of a standard motor (4-pole, 15kW):

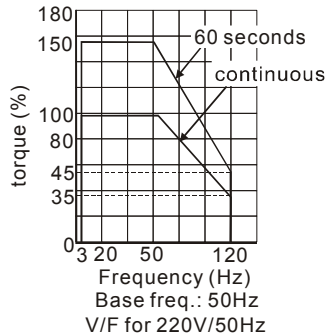
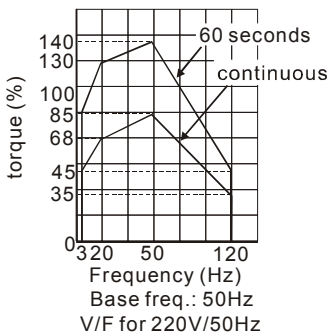
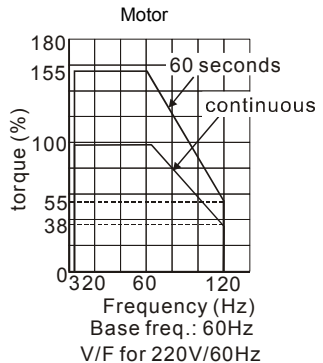
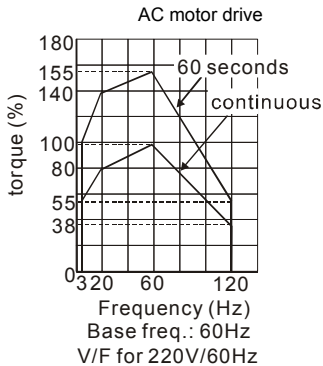

This page intentionally left blank.