

SIEMENS

SIMOREG DC MASTER 6RA70 Digital Chassis Converters

Catalog DA 21.1 · 2001



DC DRIVES
SIEMENS

Catalogs for "Large Drives"

DC Motors

DA 12



Order No.:
German: E20002-K4012-A101-A2
English: E20002-K4012-A101-A2-7600

DC Motors 1GG7, 1GH7, 1HS7 and 1HQ7

DA 12 Supplement
July 2001

Order No.:
German: E86060-K5112-E101-A1
English: E86060-K5112-E101-A1-7600

DC Drives Preferred Series up to 500 kW

DA 12.1



Order No.:
German: E20002-K4012-A111-A2
English: E20002-K4012-A111-A2-7600

DC Drives Preferred Series 215 kW to 1500 kW

DA 12.2



Order No.:
German: E20002-K4012-A121-A1
English: E20002-K4012-A121-A1-7600

SIMOREG 6RA70 DC MASTER Digital Chassis Converters

DA 21.1



Order No.:
German: E86060-K5121-A111-A1
English: E86060-K5121-A111-A1-7600

SIMOREG 6RA22 Analog Chassis Converters (available soon)

DA 21.2



Order No.:
German: E86060-K4021-A121-A1
English: E86060-K4021-A121-A1-7600

Spare Parts for SIMOREG Converters (Chassis Units)

DA 21 E



Order No.:
German: E20002-K4021-A900-A4
English: E20002-K4021-A900-A4-7600

SIMOREG Static Converter Cabinets

DA 22



Order No.:
German: E20002-K4022-A101-A3
English: E20002-K4022-A101-A3-7600

Automation and Drives

CA 01



Order No.:
German: E86060-D4001-A100-B5
English: E86060-D4001-A110-B4-7600

Internet

Visit Siemens Automation and Drives Group on the Internet
at <http://www.siemens.de/automation>

SIEMENS

SIMOREG DC MASTER 6RA70

Digital
Chassis Converters

Catalog DA 21.1 · 2001

Supersedes: Catalog DA 21 · 1999, Part 1

Overview

1

System Overview

2

Technical Data

3

Options

4

Planning Guide

5

SIMOREG CM

6

Selection and Ordering Data

7

Dimension Drawings

8

Documentation and Training

9

Appendix

A

Note!

The technical data is intended for general information.

Please observe the Operating Instructions and the references indicated on the products for installation, operation and maintenance.

© BERO, MICROMASTER, SIMADYN, SIMATIC, SIMATIC HMI, SIMODRIVE, SIMOLINK, SIMOREG, SIMOVERT, SITOP, STEP, STRUC, USS are Siemens registered trademarks.

All other products and systems names in this catalog are (registered) trademarks of their respective owners and must be treated accordingly.

- The technical data, selection and ordering data (Order Nos.), accessories and availability are subject to alteration.
- All dimensions in this catalog are stated in mm.

SIMOREG 6RA70 DC MASTER Overview



1/2

Application

1/4

Overview of types

1/4

Guide

1

SIMOREG® 6RA70 DC MASTER

Overview

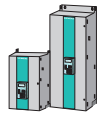

Application

1

Well-proven drive technology: Rugged, dynamic and low-priced

Depending on the application, DC drives are often the most economical drive solution.

They also have many advantages in terms of reliability, user-friendliness and operational response. A number of technical and commercial factors are as important now as they have been in the past for deployment of DC drives in many sectors of industry:

- Low-cost 4-quadrant operation
- Continuous duty at low speed
- Full torque even at low speeds
- High starting torque
- Wide speed range for constant power
- Minimal space requirements
- Reliability

Perfect for all requirements

In DC technology, anyone who is looking for optimal economy should start with the SIMOREG DC MASTER family – converters with top performance as well as integrated intelligence. They are known for maximum operational reliability and availability – world-wide in a wide range of different fields:

- Main drives for printing machines
- Rubber and plastics industry
- Traversing and lifting drives in the lifting gear industry
- Elevator and cable car drives
- Applications in paper manufacturing
- Cross-cutter drives in the steel industry
- Rolling mill drives
- Winding drives
- Loading machines for motor, turbine and gearbox test beds.

One complete family: SIMOREG DC MASTER

The SIMOREG DC MASTER family is available in every possible variation – for a power range from 6.3 kW to 1900 kW, for armature and field supply and for single/two or four-quadrant operation. And the SIMOREG DC MASTERS feature a highly dynamic response: Their current or torque rise time is significantly below 10 ms. You will always find the right variant for your application. And these are their most important characteristics:

- For total integration into every automation environment
- Modular expansion capability throughout
- From standard applications to high-performance solutions
- Redundant drive configurations up to 12,000 A thanks to intelligent parallel connection

- Rated input voltage from 400 V to 830 V
- Quick and easy start-up thanks to the fully electronic parameterization of all settings
- Uniform operating philosophy

SIMOREG DC MASTERS naturally also feature the unique characteristic of Siemens products: TIA – Totally Integrated Automation. You profit from the totally integrated Siemens world during project engineering and programming as well as with the common database and system-wide communication.



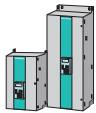

SIMOREG 6RA70 DC MASTER Overview

Application

Retrofit to make your existing systems fit again

You can also benefit from these advantages in existing systems.

With the SIMOREG CM converter, you can inject new life into an old system. The Control Module provides you with a low-cost and efficient retrofit solution – whether for re-equipping or upgrading.

International standards from Siemens

Internationally approved products are taken for granted at Siemens. SIMOREG products comply with all the most important standards – ranging from the EN European standard to IEC/VDE, CE marking, UL, cUL and CSA approvals make the SIMOREG DC MASTER a genuinely global player.

At your side worldwide

SIMOREG DC MASTER converters are not only global players in terms of their compliance with international standards. Within the context of the worldwide Siemens service network, service does not end with the finely-tuned logistics concept for short delivery times, fast order processing and prompt service. With over 180 service centers in more than 110 countries, we are accessible round the clock to overcome breakdowns and to offer individually tailored business services for all aspects of products and systems. As a professional service provider, our OnCall service provides technical expertise and logistics as well as all the other components necessary to ensure an efficient service visit.

Motors, the muscles of the DC system

SIMOREG DC MASTER converters in combination with the DC motor range are the winning team. The compact DC motors from Siemens have proved themselves worldwide wherever low-cost drive technology and maximum availability are required. They are rugged and have a long service life over a power range from 0.7 kW to 1550 kW. Whether self-cooled or externally-cooled, with or without a fan, to the IP 23, IP 54 or IP 55 degree of protection: The modular design permits any combination. And what is more: Our DC motors can be integrated into the world of automation via the motor interface designed for the SIMOREG DC MASTER – for continuous monitoring, accurate diagnosis and effective maintenance.



1

SIMOREG 6RA70 DC MASTER

Overview

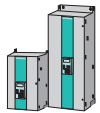

Type overview · Guide

Overview of types

1

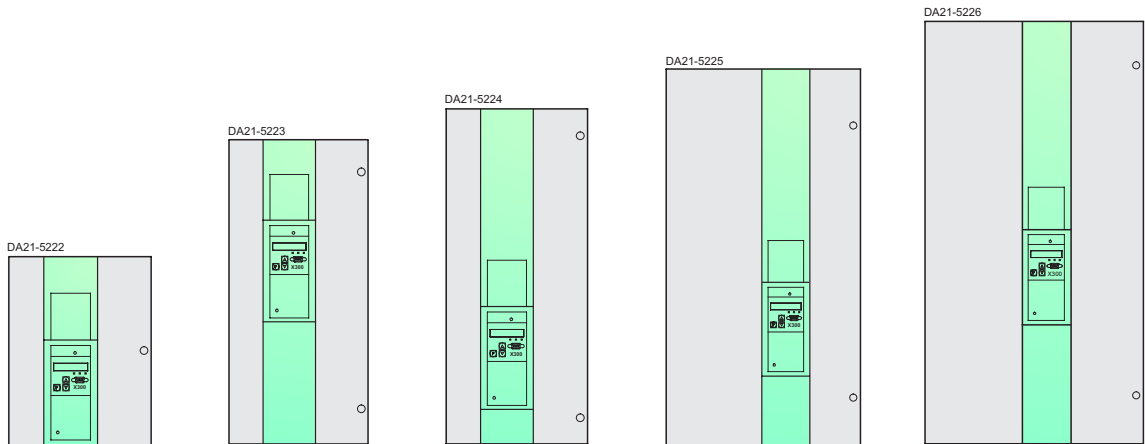

Rated supply voltage	3-ph. AC 400/460/575 V	3-ph. AC 400/460/575 V	3-ph. AC 400/460/575 V	3-ph. AC 400/460/575/690 V	3-ph. AC 400/460/575/690/830 V
Rated DC current armature	15 A – 280 A	400 A – 600 A	720 A – 850 A	900 A – 1200 A	1500 A – 2000 A
Rated DC current field	5 A – 15 A	25 A	30 A	30 A	40 A
Dimensions (H x W x D mm x mm x mm)	385 x 265 x 239-313	625 x 268 x 318	700 x 268 x 362	780 x 410 x 362	880 x 450 x 500

Guide

Section 2

You will find an overview of the performance and characteristics of the SIMOREG DC MASTER converters in [Section 2 of the system description](#). Everything that you always wanted to know about the market leader in DC drive technology or perhaps have forgotten again is presented here.

Section 3

Selecting a DC converter is easy. Make a note of the following data:

- Rated supply voltage or
- Rated DC voltage (armature voltage)
- Rated armature current
- Operating mode (1Q or 4Q)

Then select the appropriate converter from the tables in [Section 3, Technical Data](#). For voltages that differ from the standard ratings

simply select the next higher voltage class. The converters can be adjusted within the range 85 V to 830 V to any supply voltage by setting the appropriate parameters. The reduction factors that apply in the case of climatic conditions that differ from the standard (installation altitude above 1000 m and/or ambient temperature higher than 45 °C/40 °C) are also specified there. These tables also contain the complete set of technical data for the individual converter types.

Section 4

Everything that is necessary for expanding the functional scope or for integration in a drive system is described in [Section 4, Options](#). From a simple operator panel through communications and technology modules as far as rectifier modules for series connection, the expansion possibilities are almost endless.

Section 5

If you want to utilize the dynamic overload characteristics of the converters, you will find all the necessary information in [Section 5, Planning Guide](#). There are also notes and selection guidelines concerning the commutating reactors required as well as filters and other EMC topics.

Whether you want parallel connection, 12-pulse operation or redundant drive configurations – its easy with the SIMOREG DC MASTER.

Section 6

Retrofitting existing systems is becoming more and more interesting in the field of DC drives. For high power ratings in particular, it can prove sensible not to replace the power section in the system. But the customer still wants all the advantages of a modern DC drive. Our solution to this dilemma is described in [Section 6, SIMOREG CM](#).

Section 7

The data provided in [Section 7, Selection and Ordering Data](#) is probably sufficient to enable an experienced DC engineer to plan a complete converter solution. All the necessary data is summarized in this section.

Section 8

When you have found the right converter, you will certainly want to install it in a system. You will find the necessary instructions in [Section 8, Dimension Drawings](#).

Section 9

For all those who want to refresh their knowledge or who do not yet have any experience with DC drives, help is of course available. Whether at home with a training briefcase or in one of our training centers: The appropriate training aids or course structures are described in [Section 9, Documentation and Training](#).

SIMOREG 6RA70 DC MASTER System Overview



2

Overview

- 2/2 Power section and cooling
- 2/3 Parameterization devices

Design and mode of operation

- 2/5 Software structure
- 2/6 Closed-loop functions in armature circuit
- 2/8 Closed-loop functions in field circuit
- 2/8 Optimization run
- 2/8 Monitoring and diagnosis
- 2/9 Functions of inputs and outputs
- 2/11 Safety shutdown (E-STOP)
- 2/11 Serial interfaces
- 2/12 Control terminal block
- 2/12 Interface to motor

Terminal assignments

- 2/13 Terminal assignments for basic units

Open-loop and closed-loop control section

- 2/14 Block diagram of CUD1
- 2/15 Terminal assignments for CUD1

Block diagram

- 2/18 SIMOREG DC Master without fan
- 2/19 SIMOREG DC Master with fan

SIMOREG 6RA70 DC MASTER

System Overview

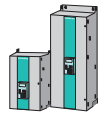

Overview

Power section and cooling

SIMOREG 6RA70 converters are fully digital, compact units for connection to a three-phase AC supply. They in turn supply the armature and field of variable-speed DC drives. The range of rated DC currents extends from 15 A to 2000 A, but can be expanded by connecting SIMOREG converters in parallel.

Converters for single-quadrant or four quadrant operation are available to suit individual applications. As the converters feature an integrated parameterization panel, they are autonomous and do not require any additional parameterization equipment. All open-loop and closed-loop control tasks as well as monitoring and auxiliary functions are performed by a microprocessor system. Setpoints and actual values can be applied in either analog or digital form.

SIMOREG 6RA70 converters are characterized by their compact, space-saving design. An electronics box containing the closed-loop control board is mounted in the converter door. This box also has space to hold additional boards for process-related expansion functions and serial interfaces. This design makes them especially easy to service since individual components are easily accessible.

External signals (binary inputs/output), analog inputs/outputs, pulse encoders, etc.) are connected by way of plug-in terminals. The converter software is stored in a flash EPROM. Software upgrades can easily be loaded via the serial interface of the basic unit.

Power section: Armature and field circuit

The armature circuit is a three-phase bridge connection:

- As a fully controlled B6C three-phase connection in converters for single-quadrant drives
- As two fully controlled (B6) A (B6) C three-phase connections in converters for four-quadrant drives.

The field circuit is a half-controlled B2HZ single-phase bridge connection.

For converters with 15 to 1200 A rated DC current, the power section for armature and field is constructed with isolated thyristor modules. The heat sink is therefore at floating potential.

For converters with rated currents ≥ 1500 A, the power section for armature and field is constructed with disc-type thyristors and heat sinks at voltage potential. All connecting terminals for the power section are accessible from the front.

Cooling

Converters with rated DC currents up to 125 A are self-cooled, while converters with rated DC currents of 210 A and higher have forced-air cooling (fan assembly).

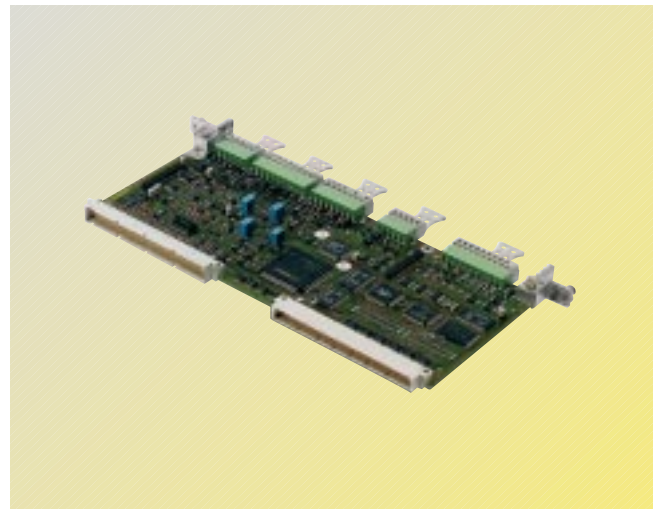

Fig. 2/1
Basic electronics board

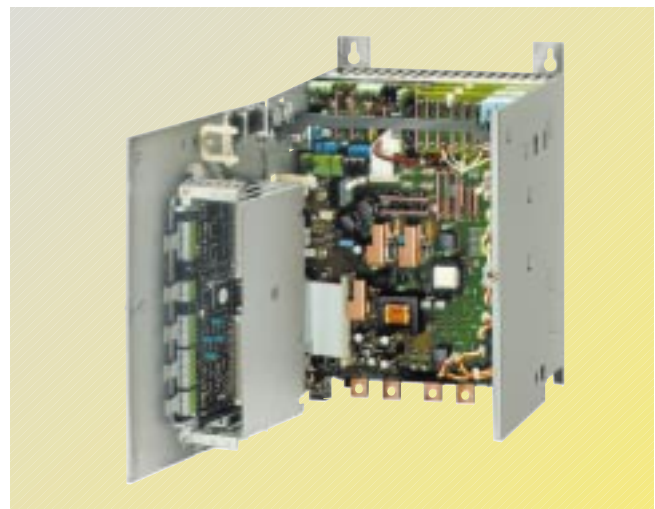

Fig. 2/2
SIMOREG 6RA70, 15 A/30 A



Fig. 2/3
SIMOREG 6RA70, 2000 A



Parameterization devices

PMU simple operator panel

All units feature a PMU panel mounted in the converter door. The PMU consists of a five-digit, seven-segment display, three LEDs as status indicators and three parameterization keys.

The PMU is also equipped with connector X300 with a USS interface in compliance with the RS232 or RS485 standard.

The panel provides all the facilities required during start-up for making adjustments or settings and displaying measured values. The following functions are assigned to the three panel keys:

- **P (select) key**
Switches over between parameter number and parameter value and vice versa, acknowledges fault messages.
- **UP key**
Selects a higher parameter number in parameter mode or raises the set and displayed parameter value in value mode. Also selects a higher index on indexed parameters.
- **DOWN key**
Selects a lower parameter number in parameter mode or reduces the set and displayed parameter value in value mode. Also selects a lower index on indexed parameters.
- **LED functions**
 - **Ready:** Ready to operate, lights up in the "Wait for operation enable" state.
 - **Run:** In operation, lights up when operation is enabled.
 - **Fault:** Disturbance, lights up in "Active fault" status, flashes when alarm is active.

The quantities output on the five-digit, seven-segment display are easy to understand, e.g.,

- Percentage of rated value
- Servo gain factor
- Seconds
- Amperes or
- Volts

OP1S converter operator panel

The OP1S optional converter operator panel can be mounted either in the converter door or externally, e.g. in the cubicle door. For this purpose, it can be connected up by means of a 5 m long cable. Cables of up to 200 m in length can be used if a separate 5 V supply is available. The OP1S is connected to the SIMOREG via connector X300.

The OP1S can be installed as an economic alternative to control cubicle measuring instruments which display physical measured quantities.

The OP1S features an LCD with 4 x 16 characters for displaying parameter names in plain text. English, German, French, Spanish and Italian can be selected as the display languages. The OP1S can store parameter sets for easy downloading to other devices.

- **Keys on OP1S:**
 - Select key (P)
 - UP key ¹⁾
 - DOWN key
 - Reversing key ¹⁾
 - ON key ¹⁾
 - OFF key ¹⁾
 - Inching key (Jog) ¹⁾
 - Numeric keys (0 to 9)
- **LEDs on OP1S:**
 - **Green:** Lights up in "Run", flashes in "Ready"
 - **Red:** Lights up with "Fault", flashes with "Alarm"
- **RESET key ¹⁾**

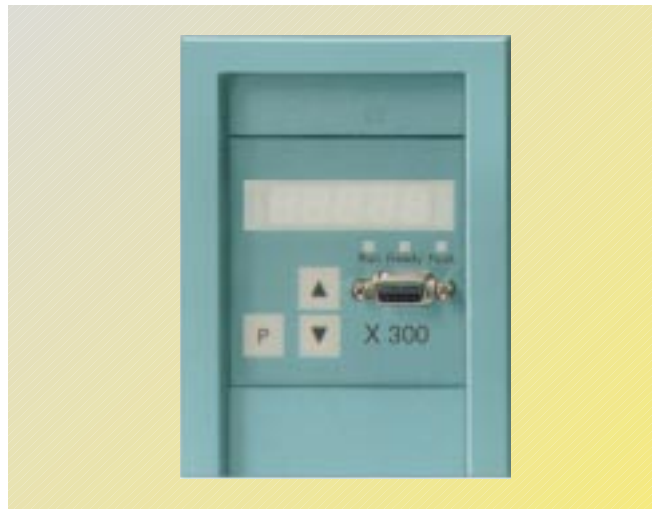

Fig. 2/4
PMU operation and parameterization unit



Fig. 2/5
OP1S user-friendly operator control panel

1) This function must be activated with parameters and is freely selectable.

SIMOREG 6RA70 DC MASTER

System Overview



Overview

Parameterization devices

Parameterization via PC

To allow start-up and trouble-shooting using a PC, the Drive-Monitor software is supplied with the converters.

The PC is linked to the SIMOREG via the USS interface on the basic unit.

The software provides the following functions:

- Menu-assisted access to parameters.
- Reading and writing of parameter sets.
- Copying of existing parameter sets to other converters of the same type.
- Output of parameter sets to a printer.

- Operation via control words (binary commands such as ON/OFF instructions, etc.) and specification of setpoints.
- Monitoring via status words (checkback information about converter status) and readout of actual values.
- Reading of fault messages and alarms.
- Readout of trace buffer contents (oscilloscope function integrated in SIMOREG).



Fig. 2/6

2

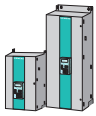

SIMOREG 6RA70 DC MASTER

System Overview

Design and mode of operation

Software structure

Software structure

Two powerful microprocessors (C163 and C167) perform all closed-loop and drive control functions for the armature and field circuits. Closed-loop control functions are implemented in the software as program modules that are "wired up" via parameters.

Connectors

All important quantities in the closed-loop control system can be accessed via connectors. They correspond to measuring points and can be accessed as digital values. 14 bits (16,384 steps) correspond to 100% in the standard normalization. These values can be used for other purposes in the converters, e.g. to control a setpoint or change a limit. They can also be output via the operator panel, analog outputs and serial interfaces.

The following quantities are available via connectors:

- Analog inputs and outputs
- Inputs of actual-value sensing circuit
- Inputs and outputs of ramp-function generator, limitations, gating unit, controllers, freely available software modules
- Digital fixed setpoints
- General quantities such as operating status, motor temperature, thyristor temperature, alarm memory, fault memory, operating hours meter, processor capacity utilization.

Binectors

Binectors are digital control signals which can assume a value of "0" or "1". They are employed, for example, to inject a setpoint or execute a control function. Binectors can also be output via the operator panel, binary outputs or via serial interfaces.

The following states can be accessed via binectors:

- Status of binary inputs
- Fixed control bits
- Status of controllers, limitations, faults, ramp-function generator, control words, status words.

Intervention points

The inputs of software modules are defined at intervention points using the associated parameters. At the intervention point for connector signals, the connector number of the desired signal is entered in the relevant parameter so as to define which signal must act as the input quantity. It is therefore possible to use both analog inputs and signals from interfaces as well as internal variables to specify setpoints, additional setpoints, limitations, etc.

The number of the binector to act as the input quantity is entered at the intervention point for binector signals. A control function can therefore be executed or a control bit output by means of either binary inputs, control bits of the serial interfaces or control bits generated in the closed-loop control.

Switchover of parameter sets

Four copies of parameters with numbers ranging from P100 to P599 as well as some others are stored in the memory. Binectors can be used to select the active parameter set. This function allows, for example, up to four different motors to be operated alternately or four different gear changes to be implemented on one converter. The setting values for the following functions can be switched over:

- Definition of motor and pulse encoder
- Optimization of closed-loop control
- Current and torque limitation
- Conditioning of speed controller actual value
- Speed controller
- Closed-loop field current control
- Closed-loop e.m.f. control
- Ramp-function generator
- Speed limitation
- Monitors and limit values
- Digital setpoints
- Technology controller
- Motorized potentiometer
- Friction compensation
- Flywheel effect compensation
- Speed controller adaptation.

Switchover of BICO data sets

The BICO data set can be switched over by the control word (binector input). It is possible to select which connector or binector quantity must be applied at the intervention point. The control structure or control quantities can therefore be flexibly adapted.

Motorized potentiometer

The motorized potentiometer features control functions "Raise", "Lower", "Clockwise/Counterclockwise" and "Manual/Auto" and has its own ramp-function generator with mutually independent ramp time settings and a selectable rounding factor. The setting range (minimum and maximum output quantities) can be set by means of parameters. Control functions are specified via binectors.

In Automatic mode ("Auto" setting), the motorized potentiometer input is determined by a freely selectable quantity (connector number). It is possible to select whether the ramping times are effective or whether the output is switched directly through to the output.

In the "Manual" setting, the setpoint is adjusted with the "Raise setpoint" and "Lower setpoint" functions. It is also possible to define whether the output must be set to zero or the last value stored in the event of a power failure. The output quantity is freely available at a connector, e.g. for use at a main setpoint, additional setpoint or limitation.

SIMOREG 6RA70 DC MASTER

System Overview

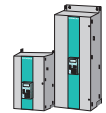

Design and mode of operation

Closed-loop functions in armature circuit

Speed setpoint

The source for the speed setpoint and additional setpoints can be freely selected through parameter settings, i.e. the setpoint source can be programmed as:

- Analog values
0 to ± 10 V, 0 to ± 20 mA, 4 to 20 mA
- Integrated motorized potentiometer
- Binectors with functions: Fixed setpoint, inch, crawl
- Serial interfaces on basic unit
- Supplementary boards

The normalization is such that 100 % setpoint (product of main setpoint and additional setpoints) corresponds to the maximum motor speed.

The speed setpoint can be limited to a minimum or maximum value by means of a parameter setting or connector. Furthermore, "adding points" are included in the software to allow, for example, additional setpoints to be injected before or after the ramp-function generator. The "setpoint enable" function can be selected with a binector. After smoothing by a parameterizable filter (PT1 element), the total setpoint is transferred to the setpoint input of the speed controller. The ramp-function generator is effective at the same time.

Actual speed value

One of four sources can be selected as the actual speed signal.

- *Analog tachometer*
The voltage of the tachogenerator at maximum speed can be between 8 and 250 V. The voltage/maximum speed normalization is set in a parameter.

- *Pulse encoder*

The type of pulse encoder, the number of marks per revolution and the maximum speed are set via parameters. The evaluation electronics are capable of processing encoder signals (symmetrical: With additional inverted track or asymmetrical: Referred to ground) up to a maximum differential voltage of 27 V.

The rated voltage range (5 V or 15 V) for the encoder is set in a parameter. With a rated voltage of 15 V, the SIMOREG converter can supply the voltage for the pulse encoder. 5 V encoders require an external supply. The pulse encoder is evaluated on the basis of three tracks: track 1, track 2 and zero marker. Pulse encoders without a zero marker may also be installed. The zero marker allows an actual position to be acquired. The maximum frequency of the encoder signals must not exceed 300 kHz. Pulse encoders with at least 1024 pulses per revolution are recommended (to ensure smooth running at low speeds).

- *Operation without tachometer and with closed-loop e.m.f. control*

No actual value sensor is needed if the closed-loop e.m.f. control function is employed. Instead, the converter output voltage is measured in the SIMOREG. The measured armature voltage is compensated by the internal voltage drop in the motor (I*R compensation). The degree of compensation is automatically determined during the current controller optimization run. The accuracy of this control method is determined by the temperature-dependent change in resistance in the motor armature circuit and equals

approximately 5%. In order to achieve greater accuracy, it is advisable to repeat the current controller optimization run when the motor is warm. Closed-loop e.m.f. control can be employed if the accuracy requirements are not particularly high, if there is no possibility of installing an encoder and if the motor is operated in the armature voltage control range.

Important: The drive cannot be operated in e.m.f.-dependent field-weakening mode when this control method is employed.

- *Freely selectable actual speed signal*

Any connector number can be selected as the actual speed signal for this operating mode. This setting is selected in most cases if the actual speed sensor is implemented on a technological supplementary board.

Before the actual speed value is transferred to the speed controller, it can be smoothed by means of a parameterizable smoothing (PT1 element) and two adjustable band filters. The band filters are used mainly to filter out resonant frequencies caused by mechanical resonance. The resonant frequency and the filter quality can be selected.

Ramp-function generator

The ramp-function generator converts the specified setpoint after a step change into a setpoint signal that changes constantly over time. Ramp-up and ramp-down times can be set independently of one another. The ramp-function generator also features a lower and upper transition rounding (jerk limitation) which take effect at the beginning and end of the ramp time respectively.

All time settings for the ramp-function generator are mutually independent.

Three parameter sets are provided for the ramp-function generator times. These can be selected via binary selectable inputs or a serial interface (via binectors). The generator parameters can be switched over while the drive is in operation. The value of parameter set 1 can also be weighted multiplicatively via a connector (to change generator data by means of a connector). When ramp-function generator time settings of zero are entered, the speed setpoint is applied directly to the speed controller.

Speed controller

The speed controller compares the speed setpoint and actual value and if these two quantities deviate, it applies a corresponding current setpoint to the current controller (operating principle: Closed-loop speed control with subordinate current controller). The speed controller is a PI controller with an additional selectable D component. A switchable speed droop can also be parameterized. All controller characteristics can be set independently of one another. The value of K_p (gain) can be adapted as the function of a connector signal (external or internal).



Closed-loop functions in armature circuit

The P gain of the speed controller can be adapted as a function of actual speed, actual current, setpoint/actual value deviation or winding diameter. To achieve a better dynamic response in the speed control loop, a feedforward control function can be applied. For this purpose, a torque setpoint quantity can be added after the speed controller as a function of friction or drive moment of inertia. The friction and moment of inertia compensation values can be calculated in an automatic optimization run.

The output quantity of the speed controller directly after enabling can be set via a parameter.

Depending on how parameters are set, the speed controller can be bypassed and the converter can be operated under torque or current control. Furthermore, it is possible to switch between closed-loop speed control and closed-loop torque control in operation by means of the selection function "Master/slave switchover". The function can be selected as a binector via a binary assignable-function terminal or a serial interface. The torque setpoint is applied by means of a selectable connector and can thus be supplied by an analog assignable-function terminal or a serial interface.

In "slave drive" operation (under torque or current control), a limiting controller is operating. It can intervene on the basis of an adjustable, parameterized speed limit in order to prevent the drive from accelerating too far. In this case, the drive is limited to an adjustable speed deviation.

Torque limitation

Depending on parameterization, the speed controller output acts as either the torque setpoint or current setpoint. In closed-loop torque control mode, the speed controller output is weighted with machine flux Φ and then transferred as a current setpoint to the current limitation. Torque-control mode is usually used in conjunction with field weakening so that the maximum motor torque can be limited independently of speed.

The following functions are available:

- Independent setting of positive and negative torque limits via parameters.
- Switchover of torque limit via a binector as a function of a parameterizable changeover speed.
- Free input of torque limit by means of a connector, e.g. via an analog input or serial interface.

The lowest input quantity is always applied as the current torque limit. Additional torque setpoints can be added after the torque limit.

Current limitation

The purpose of the current limitation set after the torque limit is to protect the converter and motor. The lowest input quantity is always applied as the current limit.

The following current limit values can be set:

- Independent setting of positive and negative current limits via parameters (setting of maximum motor current).

- Free input of current limit by means of a connector, e.g. via an analog input or serial interface.
- Separate setting of current limit via parameters for shut-down and fast stop.
- Speed-dependent current limitation: Parameters can be set to implement an automatically triggered speed-dependent reduction in the current limitation at high speeds (commutation limit curve of motor).
- P_t monitoring of the power section: The temperature of the thyristors is calculated for all current values. When the thyristor limit temperature is reached, the converter current is either reduced to rated DC current or the converter is shut down with a fault message, depending on how the appropriate response parameter is set. This function is provided to protect the thyristors.

Current controller

The current controller is a PI controller with mutually independent P gain and reset time settings. The P or I component can also be deactivated (to obtain a pure P controller or a pure I controller). The actual current is acquired on the three-phase AC side by means of current transformers and applied to the current controller after A/D conversion via a resistive load and a rectifying circuit. The resolution is 10 bits for converter rated current. The current limiting output is applied as the current setpoint.

The current controller output transfers the firing angle to the gating unit, the feedforward control function acts in parallel.

Feedforward control

The feedforward control function in the current control loop improves the dynamic response of the control. This allows rise times of between 6 and 9 ms to be achieved in the current control loop. The feedforward control operates as a function of the current setpoint and motor e.m.f. and ensures that the necessary firing angle is transferred speedily to the gating unit in both intermittent and continuous DC operation or when the torque direction is reversed.

Auto-reversing module

The auto-reversing module (only on converters for four-quadrant drives) acts in conjunction with the current control loop to define the logical sequence of all processes required to reverse the torque direction. One torque direction can be disabled by a parameter setting if necessary.

Gating unit

The gating unit generates the gate pulses for the power section thyristors in synchronism with the line voltage. Synchronization is implemented independently of the rotating field and electronics supply and is measured on the power section. The gating pulse position timing is determined by the output values of the current controller and feedforward control. The firing angle setting limit can be set in a parameter.

The gating unit is automatically adjusted to the connected line frequency within a frequency range of 45 Hz to 65 Hz.

Adaptation to the line frequency within a frequency range of 23 Hz to 110 Hz via separate parameterization is available [on request](#).

SIMOREG 6RA70 DC MASTER

System Overview



Design and mode of operation

Closed-loop functions in field circuit

E.m.f. controller

The e.m.f. controller compares the e.m.f. (induced motor voltage) setpoint and the actual value and specifies the setpoint for the field current controller. This provides e.m.f.-dependent closed-loop field-weakening control.

The e.m.f. controller operates as a PI controller, the P and I components can be set independently of one another. The controller can also be operated as a pure P or pure I controller. A feedforward control also operates in parallel with the e.m.f. controller. This applies feedforward control as a function of speed to the field current setpoint by means of an automatically recorded field characteristic (see optimization runs). An adding point is located after the e.m.f. controller at which additional field current setpoints can be entered via a connector, e.g. analog input or serial interface. The limitation for the field current setpoint is then applied. The maximum and minimum setpoint limits can be set independently of one another. The limitation is implemented via a parameter or connector. The minimum is applied as the upper limit and the maximum is applied for the lower limit.

Field current controller

The current controller for the field is a PI controller with independent settings for K_p and T_n . It can also be operated as a pure P or pure I controller. A feedforward control operates in parallel with the field current controller. This calculates and sets the firing angle for the field circuit as a function of current setpoint and line voltage. The feedforward control supports the current controller and ensures a dynamic response in the field circuit.

Gating unit

The gating unit generates the gate pulses for the power section thyristors in synchronism with the line voltage in the field circuit. Synchronization is measured on the power section and is not therefore dependent on the electronics supply. The gating pulse position timing is determined by the output values of the current controller and feedforward control. The firing angle setting limit can be set in a parameter. The gating unit is automatically adjusted to the connected line frequency within a frequency range of 45 Hz to 65 Hz.

Optimization run

6RA70 converters are supplied with parameters set to the factory settings. Automatic optimization runs can be selected by means of special key numbers to support setting of the controllers.

The following controller functions can be set in an automatic optimization run:

- Current controller optimization run for setting current controllers and feedforward controls (armature and field circuit).
- Speed controller optimization run for setting characteristic data for the speed controller.
- Automatic recording of friction and moment of inertia compensation for feedforward control of speed controller.
- Automatic recording of the field characteristic for an e.m.f.-dependent closed-loop field-weakening control and automatic optimization of the e.m.f. controller in field-weakening operation.

Furthermore, all parameters set automatically during optimization runs can be altered afterwards on the operator panel.

Monitoring and diagnosis

Display of operational data

The operating status of the converter is displayed via parameter r000. Approximately 50 parameters are provided for displaying measured values. An additional 300 signals from the closed-loop control can be selected in the software (connectors) for output on the display unit. Examples of displayable measured values: Setpoints, actual values, status of binary inputs/outputs, line voltage, line frequency, firing angle, inputs/outputs of analog terminals, display of limitations.

Trace function

The trace function can be selected to store up to 8 measured quantities with 128 measuring points each. A measured quantity or the activation of a fault message can be parameterized as a trigger condition. It is possible to record the pre-event and post-event history by programming a trigger delay. The sampling time for the measured value memory can be parameterized to between 3 and 300 ms.

Measured values can be output via the operator panels or serial interfaces.

2



Fig. 2/7
SIMOREG converter family



Monitoring and diagnosis

Fault messages

A number is allocated to each fault message. The time at which the event occurred is also stored with the fault message. This allows the cause of the fault to be pinpointed promptly. The most recent eight fault messages are stored with fault number, fault value and hours count for diagnostic purposes.

When a fault occurs

- The binary output function "Fault" is set to LOW (selectable function),
- The drive is switched off (controller disable and current $I = 0$, pulse disable, relay "Line contactor CLOSED" drops out) and
- An "F" with a fault number appears on the display, the "Fault" LED lights up.

Fault messages can be acknowledged on the operator panel, via a binary assignable-function terminal or a serial interface. When a fault has been acknowledged, the system switches to the "Starting lockout" status. "Starting lockout" is cancelled by OFF (L signal at terminal 37).

Automatic restart: The system can be restarted automatically within a parameterizable time period of 0 to 2s. If this time is set to zero, a fault message is activated immediately (on power failure) without a restart. Automatic restart can be parameterized in connection with the following fault messages: Phase failure (field or armature), undervoltage, overvoltage, failure of electronics power supply, undervoltage on parallel SIMOREG unit.

Fault/error messages are divided into the following categories:

- **Line fault:** Phase failure, fault in field circuit, undervoltage, overvoltage, line frequency < 45 or > 65 Hz
- **Interface fault:** Basic unit interfaces to supplementary boards are malfunctioning
- **Drive fault:** Monitor for speed controller, current controller, e.m.f. controller, field current controller has responded, drive blocked, no armature current
- **Electronic motor overload protection (I^2t monitor for motor) has responded)**
- **Tacho-generator monitor and overspeed signal**
- **Start-up error**
- **Fault on electronics board**
- **Fault message from thyristor check:** This fault message will only occur if the thyristor check is activated via the appropriate parameter. The check function ascertains whether the thyristors are capable of blocking and firing
- **Fault messages from motor sensors (with terminal expansion option):** Monitoring of brush length, bearing condition, air flow, motor temperature has responded
- **External faults via binary assignable-function terminals.**

Fault messages can be deactivated individually. The default setting for some fault messages is "deactivated" so they need to be activated in the appropriate parameter.

Alarms

Special states that do not lead to drive shutdown are indicated by alarms. Alarms do not need to be acknowledged, but are automatically reset when the cause of the problem has been eliminated.

When one or several alarms occur

- The binary output function "Alarm" is set to LOW (selectable function) and
- The alarm is indicated by a flashing "Fault" LED.

Alarms are divided into the following categories:

- **Motor overtemperature:** The calculated I^2t value of the motor has reached 100 %
- **Alarms from motor sensors (with terminal expansion option only):** Monitoring of bearing condition, motor fan, motor temperature has responded
- **Drive alarms:** Drive blocked, no armature current
- **External alarms via binary assignable-function terminals**
- **Alarms from supplementary boards.**

Functions of inputs and outputs

Analog selectable inputs

After conversion to a digital value, the quantity at the analog inputs can be flexibly adjusted in terms of normalization, filtering, sign selection and offset via parameters. Since these values are available as connectors, the analog inputs can also act as a main setpoint or an additional setpoint or limitation.

Analog outputs

The actual current is output as a real-time quantity at terminal 12. The output can be parameterized as a bipolar quantity or absolute value, with selectable polarity.

Selectable analog outputs are provided for the output of other analog signals. They can be output in the form of a bipolar signal or absolute value. The normalization, offset, polarity and a filtering time can also be parameterized. The required output quantities are selected by means of connector numbers specified at intervention points. Possible outputs are, for example, actual speed, ramp-function generator output, current setpoint, line voltage, etc.

SIMOREG 6RA70 DC MASTER

System Overview

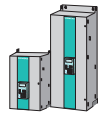

Design and mode of operation

Functions of inputs and outputs

Binary inputs

- **Switch-on/Shutdown (OFF1) via terminal 37.**
This terminal function is ANDed with the control bit of the serial interface. With an H signal applied to terminal 37, the main contactor (terminal 109/110) is energized via an internal sequence control. If an H signal is applied to terminal 38 (enable operation), then the controllers are enabled. The drive accelerates at the speed setpoint up to operating speed. With an L signal at terminal 37, the drive is decelerated along the deceleration ramp down to speed $n < n_{\min}$ and when the brake control delay has expired, the controllers are disabled and the main contactor is de-energized when $I = 0$. The field current is then reduced to its standstill value (parameterizable) after a parameterizable delay following main contactor dropout has expired.
- **Enable operation via terminal 38**
This function is ANDed with the control bit of the serial interface. The controllers are enabled with an H signal applied to terminal 38. With an L signal at terminal 38, the controllers are disabled and, at $I = 0$, the pulses are disabled too. The "Enable operation" signal has high priority, i.e. if it changes to "L" during operation, the effect is always $I = 0$, causing the drive to coast to a standstill.

Binary selectable inputs:

Further binary input terminals are provided for optional function selections. A binector number is assigned to each assignable-function terminal for use for control functions.

Examples of binary input functions:

- **Voltage disconnect (OFF 2):** With an OFF 2 (L signal), the controllers are disabled instantaneously, the armature circuit current is reduced and when $I = 0$, the main contactor is de-energized. The drive coasts down in an uncontrolled manner.
- **Fast stop (OFF 3):** With a fast stop (low) signal, the speed setpoint at the speed controller input is set to zero and the drive is braked along the current limit (separate current limit can be parameterized for fast stop). When $n < n_{\min}$ is input, on expiry of the brake control delay time, $I = 0$ is input and the main contactor is deactivated.
- **INCH:** The inching function is available with an L signal at terminal 37, an H signal at terminal 38 and activation of inching mode. In active inching mode, the main contactor is energized and the drive is accelerated to a parameterized inching setpoint. When the inching signal is cancelled, the drive is braked down to $n < n_{\min}$; the controllers are then disabled and the main contactor is de-energized after a parameterizable delay (0 to 60 s) has elapsed. It is also possible to select whether the ramp function generator must be active in inching mode or whether a ramp-up time = ramp-down time = 0 should be applied.

Binary outputs

Selectable signaling functions are available at binary output terminals (open emitter output). Any binector quantity, chosen by the appropriate selection parameter, can be output at each terminal. The polarity of the output signal and a settable delay (0 to 15 s) can also be parameterized.

Examples of binary output functions:

- **Fault:** An L signal is output when a fault message is active.
- **Alarm:** An L signal is output when an alarm is active.
- **$n < n_{\min}$:** An H signal is output at speeds of less than n_{\min} . This signal is used, for example, to activate a "zero speed" message.
- **Switch-on command for a mechanical brake:** A motor brake can be activated via this signal.

When the drive is switched on with the "Drive ON" function and "Enable operation" signal, an H signal is output to release the brake; output of the internal controller enable signal is delayed for a parameterizable period (corresponding to mechanical release time). When the drive is stopped via the "Shutdown" or "fast stop" function, an L signal to close the brake is output when a speed of $n < n_{\min}$ is reached. At the same time, the internal controller enable signal remains active for a parameterizable time period (corresponding to mechanical brake closing time). $I = 0$ is then input, the pulses are disabled and the main contactor is de-energized.

A further operating mode can be selected for the "Close brake" signal (L signal at binary selectable output). With this option, there is no delay until $n < n_{\min}$ is reached when "Internal controller disable" is applied (drive is at zero current), but instead, the (operating) brake is activated at speeds greater than n_{\min} .

An internal controller disable signal is output in response to fault messages, voltage disconnection or cancellation of the "Enable operation" signal at terminal 38 during operation.

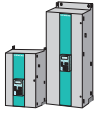

SIMOREG 6RA70 DC MASTER System Overview

Design and mode of operation

2

Safety shutdown (E-STOP)

The task of the E-STOP function is to open the relay contacts (terminals 109/110) for energizing the main contactor within about 15 ms, independently of semiconductor components and the functional status of the microprocessor board (basic electronics). If the basic electronics are operating correctly, the closed-loop control outputs an $I = 0$ command to de-energize the main contactor. When an E-STOP command is given, the drive coasts to a standstill.

The E-STOP function can be triggered by one of the following methods:

- Switch operation: E-STOP is activated when the switch between terminals 105 and 106 opens.
- Pushbutton operation: Opening an NC contact between terminals 106 and 107 triggers the E-STOP function and stores the shutdown operation. Closing an NO contact between terminals 106 and 108 resets the function.

When the E-STOP function is reset, the drive switches to the "Starting lockout" state. This status needs to be acknowledged through activation of the "Shutdown" function, e.g. by opening terminal 37.

Note: The E-STOP function is not an EMERGENCY STOP function according to EN 60204-1.

Serial interfaces

The following serial interfaces are available:

- One serial interface on connector X300 on the PMU for a USS protocol to the RS 232 or RS 485 standard. For connection of optional OP1S operator panel or for PC-based DriveMonitor.
- One serial interface at terminals of the basic electronics board, two-wire or four-wire RS485 for USS protocol or peer-to-peer connection.
- One serial interface at terminals of the terminal expansion board (option), two-wire or four-wire RS485 for USS protocol or peer-to-peer connection.
- PROFIBUS-DP on a supplementary card (option).
- SIMOLINK[®] on a supplementary card (optional) with fiber-optic connection.

Physical characteristics of interfaces

- RS 232: ± 12 V interface for point-to-point operation.
- RS 485: 5 V normal mode interface, noise-proof, for an additional bus connection with a maximum of 31 bus nodes.

USS protocol

Disclosed SIEMENS protocol, easy to program on external systems, e.g. on a PC, any master interfaces can be used. The drives operate as slaves on a master. The drives are selected via a slave number.

The following data can be exchanged via the USS protocol:

- PKW data for writing and reading parameters.
- PZD data (process data) such as control words, setpoints, status words, actual values.

Connector numbers are entered in parameters to select the transmit data (actual values), the receive data (setpoints) represent connector numbers that can be programmed to act at any intervention points.

Peer-to-peer protocol

The peer-to-peer protocol is used to link one converter to another. With this mode, data are exchanged between converters, e.g. to build a setpoint cascade, via a serial interface. Since a serial interface is employed as a four-wire line, it is possible to receive data from the upstream converter, condition them (e.g. through multiplicative weighting) and then send them to the downstream converter. Only one serial interface is used for the whole operation.

The following data can be exchanged between converters:

- Transmission of control words and actual values.
- Receipt of status words and setpoints.

Up to five data words are transmitted in each direction. Data are exchanged on the basis of connector numbers and intervention points.

The serial interfaces can be operated simultaneously. For example, the first interface can be used as an automation link (USS protocol) for open-loop control, diagnostics and specification of the master setpoint. A second interface operates in conjunction with the peer-to-peer protocol to act as a setpoint cascade.

SIMOREG 6RA70 DC MASTER

System Overview

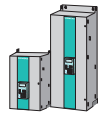

Design and mode of operation

Control terminal block

Terminals on microprocessor board (basic electronics)

- P10 reference voltage, 10 mA load rating
N10 reference voltage, 10 mA load rating
- 2 analog inputs via differential amplifiers, resolution can be set between 10 and ± 14 bits, 0 to ± 10 V, 0 to ± 20 mA, 4 to 20 mA
- 1 analog input for motor temperature sensor using PTC or KTY84
- Realtime analog output to ground for actual current value, 5 V for rated converter current, max. 2 mA
- 2 analog outputs to ground, 0 to ± 10 V, ± 11 bit resolution, max. 2 mA
- Pulse encoder evaluation for 5 or 24 V encoder, 2 tracks and zero mark, maximum frequency 300 kHz
- P15 power supply, 200 mA for pulse encoder
- 4 binary inputs to ground, 2 with selectable function
- 2 binary inputs to ground, open emitter P24, 100 mA load rating
- One serial interface, two-wire or four-wire RS 485, max. 187.5 kbd
- P24 power supply for driving binary inputs
- 9 terminals for converter ground

Connectors on PMU simple operator panel

- Connector X300 for connection of OP1S, two-wire RS 232 or RS 485, max. 187.5 kbd USS interface

Terminals on gating board

- Analog tachometer 8 to 250 V for maximum speed
- E-STOP

Terminals on optional terminal expansion board

- 4 binary selectable inputs via optocouplers, can also be used as interface to motor
- 4 binary selectable inputs to ground
- 2 analog inputs to ground, ± 10 bit resolution
- 1 analog input for evaluation of motor temperature via PTC or KTY84
- 2 P24 binary inputs to ground, open emitter, 100 mA load rating
- 2 analog outputs to ground, ± 10 V, 2 mA load rating, ± 11 -bit resolution
- 1 serial interface, two-wire and four-wire RS 485, max. 187.5 kbd
- 1 parallel interface (2 connectors) for parallel connection of SIMOREG
- P24 power supply for driving binary inputs
- 8 terminals for converter ground

Interface to motor

Monitoring of motor temperature

The motor temperature can be monitored by either PTC thermistors or linear temperature sensors (KTY84-130). These can be connected via an input on the basic converter electronics board and an input on the optional terminal expansion board. An alarm or fault message can be parameterized for PTC thermistors. Two thresholds, one for alarm and one for shutdown, can be entered for a KTY84-130. Limit values are input and displayed in $^{\circ}\text{C}$.

A temperature switch can also be evaluated via the optional terminal expansion board. A parameterizable alarm or fault message is output when the monitor responds (binary switching signal). Signals are evaluated via the binary selectable input (Terminal 214) on the optional terminal expansion board.

Monitoring of brush length

The brush length is monitored via floating microswitches; the shortest brush in each case is evaluated. If the brush has worn out, the microswitch opens, causing an alarm or fault message (parameterizable) to be output. Signals are evaluated via the binary selectable input (Terminal 211) on the optional terminal expansion board.

Monitoring of air flow in motor fan

A ventcaptor (type 3201.03) is installed in the ventilation circuit of the motor fan for this purpose. An alarm or fault message is output when the monitor responds. Signals are evaluated via the binary selectable input (Terminal 213) on the optional terminal expansion board.

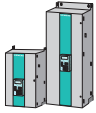

SIMOREG 6RA70 DC MASTER System Overview

Terminal assignments

2

Terminal assignments for basic units

Type	Terminal design	Function	Terminal	Connection values/comments
Power section:	Converters with • 15 and 30 A: KDS10 PCB feed-through screw-type terminal (max. cross-section 10 mm ² , stranded) • 60 to 280 A: 1U1, 1V1, 1W1: Through-hole for M8 (3 x 20 copper bus) 1C1, 1D1: Through-hole for M8 (5 x 20 copper bus) • 400 to 600 A: 1U1, 1V1, 1W1: Through-hole for M10 (5 x 30 copper bus) 1C1, 1D1: Through-hole for M10 (5 x 35 copper bus) • 720 to 850 A: Through-hole for M12 (5 x 60 copper bus) • 900 to 1200 A: Through-hole for M12 (10 x 60 copper bus) • 1500 to 2000 A: 1U1, 1V1, 1W1: Through-hole for M12 (10 x 80 copper bus) 1C1, 1D1: Through-hole for M12 (10 x 50 copper bus) The converters are designed for a permanent power supply connection according to DIN VDE 0160 Section 6.5.2.1. PE conductor connection: Minimum cross-section 10 mm ² The conductor cross-sections must be determined according to the applicable regulations, e.g. DIN VDE 100 Part 523, DIN VDE 0276 Part 1000).	Armature line input	1U1 1V1 1W1	See technical data
		Protective conductor PE	⊕	
Field circuit	• 15 to 850 A: MKDS PCB terminal block (screw-type terminal) max. cross-section 4 mm ² stranded • 900 to 2000 A: G10/4 converter terminal (screw-type) max. cross-section 10 mm ² stranded	Mains connection	XF1-2/3U1 XF1-1/3W1	2-ph. AC 400 to 460 V (+15%/–20%)
		Field winding connection	XF2-2/3C XF2-1/3D	325 V rated DC voltage with 2-ph. AC 400 V mains connection
Electronics power supply ¹⁾	• Plug-in terminal max. cross-section 1.5 mm ² stranded	Incoming supply	XP/5U1	2-ph. AC 380 to 460 V (+15%/–25%); I _n = 1 A (–35% for 1 min) or 1-ph. AC 190 to 230 V (+15%/–25%); I _n = 2 A
Fan ²⁾	Plug-in terminal (screw-terminal) Max. cross-section 4 mm ² stranded	Incoming supply	4U1 4V1 4W	3-ph. AC 400 V (±15%) For further information, see technical data
		Protective conductor PE	⊕	
Analog inputs, tachometer inputs	Plug-in terminal Max. cross-section 2.5 mm ²	Tacho connection 8 to 270 V Analog ground M	XT/103 XT/104	±270 V; > 143 kΩ Signs can be reversed and signals switched through by means of binary input functions.
Safety shutdown (E-STOP)	MSTB2.5 plug-in terminal Max. cross-section 2.5 mm ²	Supply for safety shutdown	XS/106	24 V DC, max. load 50 mA, short-circuit-proof, evaluation via fault message F018
		Safety shutdown – Switch – Pushbutton – Reset	XS/105 ³⁾ XS/107 ³⁾ XS/108 ³⁾	I _e = 20 mA NC contact I _e = 30 mA NO contact I _e = 10 mA

1) Note: For converters with a power section supply voltage that lies outside the tolerance range (note max. permissible power section supply voltage), the electronics power supply, field circuit mains connection and fan connection

must be adapted to AC 400 V via a transformer. An autotransformer is recommended for power section supply voltages up to 500 V. An isolating transformer must be used for power section supply voltages over 500 V. This isolating

transformer must have a center tap that is connected to protective earth PE.
2) On forced-ventilated converters ≥ 400 A

3) Note: Either terminal 105 or terminals 107 and 108 may be used. Terminal 105 is connected to terminal 106 in the delivery state.

SIMOREG 6RA70 DC MASTER

System Overview

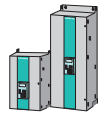

Open-loop and closed-loop control section

Block diagram of CUD1

2

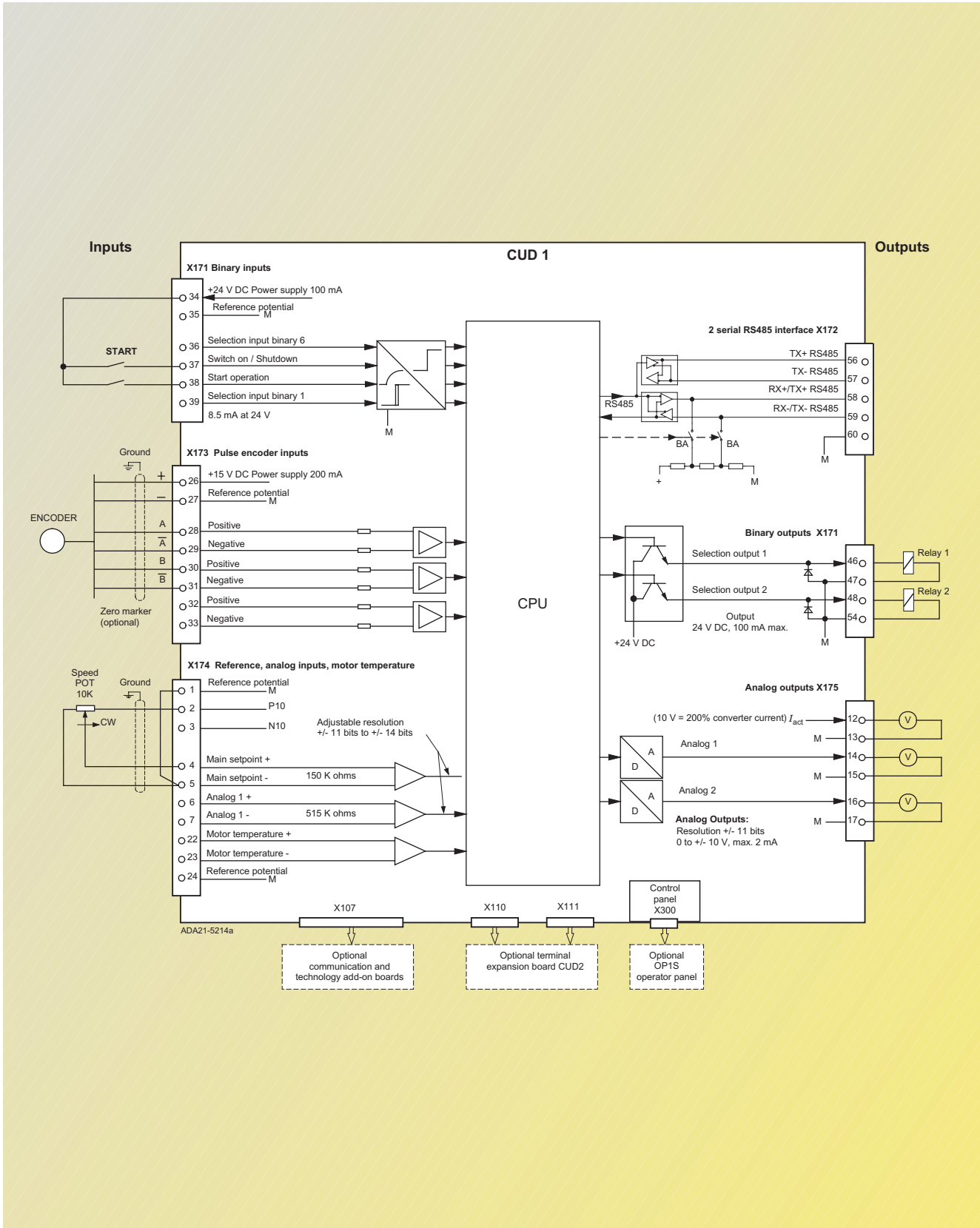

Fig. 2/8
Block diagram of CUD1 with customized connections



SIMOREG 6RA70 DC MASTER System Overview

Open-loop and closed-loop control section

Terminal assignments for CUD1

Type	Terminal design	Function	Terminal	Connection values/comments
Analog inputs, reference voltage	Plug-in (screw-type) terminal Max. cross-section 1.5 mm ²	Reference – M – P10 – N10	X174/1 X174/2 X174/3	±1% at 25° C (stability 0.1% per 10 °K); 10 mA short-circuit-proof
		Selectable input: – Main setpoint + – Main setpoint -	X174/4 X174/5	Differential input Parameter settings: ±10 V; 150 kΩ ¹⁾ Resolution can be parameterized up to approx. 555 µV (±14 bits) 0 to 20 mA; 300 Ω 4 to 20 mA; 300 Ω
Pulse encoder input	Plug-in (screw-type) terminal Max. cross-section 1.5 mm ²	Supply (+13.7 V to +15.2 V)	X173/26	200 mA; short-circuit-proof (electronic protection)
		Pulse encoder ground M	X173/27	
Other analog inputs	Plug-in terminal (screw-terminal) Max. cross-section 1.5 mm ²	Track 1: – Positive terminal	X173/28	Load: ≤ 5.25 mA at 15 V (w/o switching losses, see "Cable, cable length, shield connection") ²⁾
		– Negative terminal	X173/29	
		Track 2: – Positive terminal	X173/30	Switching hysteresis: ³⁾ Pulse/pause ratio: 1:1
		– Negative terminal	X173/31	
Zero marker: – Positive terminal	X173/32	Level of input pulses: ²⁾ Track offset: See Page 5/19, Table 5 ²⁾ Pulse frequency: See Page 5/19, Table 6 ²⁾ Cable length: ³⁾		
– Negative terminal	X173/33			
Other analog inputs	Plug-in terminal (screw-terminal) Max. cross-section 1.5 mm ²	Motor temperature: – Positive terminal	X174/22	Sensor acc. to P146, index 1 Sensor acc. to P146, index 1 PTC or KTY84-130
		– Negative terminal	X174/23	
		Analog ground M	X147/24	

2

1) Resolution can be parameterized up to approx. 555 µV (±14 bits)

2) See Section "Characteristic data of pulse tachometer electronics"

SIMOREG 6RA70 DC MASTER

System Overview

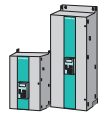

Open-loop and closed-loop control section

Terminal assignments for CUD1

Type	Terminal design	Function	Terminal	Connection values/comments
Analog outputs	Plug-in terminal (screw-terminal) Max. cross-section 1.5 mm ²	Actual current Analog ground M	X175/12 X175/13	0 ± 10 V corresponds to 0 ± 200% converter rated DC current Max. load 2 mA, short-circuit-proof
		Analog selectable output 1 Analog mass M	X175/14 X175/15	0 ± 10 V, max. 2 mA, short-circuit-proof Resolution ± 11 bits
		Analog selectable output 2 Analog mass M	X175/16 X175/17	0 ± 10 V, max. 2 mA, short-circuit-proof Resolution ± 11 bits
Binary control inputs	Plug-in terminal (screw-terminal) Max. cross-section 1,5 mm ²	Supply	X171/34	24 V DC, max. load 100 mA, internal supply referred to internal ground
		Digital ground M	X171/35	
		Switch-on/shutdown	X171/37	<ul style="list-style-type: none"> • H signal: Switch-on ¹⁾ Line contactor CLOSED + (with H signal at terminal 38) acceleration along ramp-function generator ramp to operating speed • L signal: Shutdown ¹⁾ Deceleration along ramp-function generator ramp to $n < n_{\min}$ (P370) + controller disable + line contactor OPEN.
		Enable operation	X171/38	<ul style="list-style-type: none"> • H signal: Controller enabled ¹⁾ • L signal: Controller disabled ¹⁾ The L signal also acts at a higher level on "Inch" and "Crawl".
		Binary selectable input 1	X171/39	¹⁾
Binary selectable input 6 (fault acknowledgement)	X171/36	The group message is acknowledged on a posi- tive edge. The converter remains in the fault state until the fault has been eliminated and ac- knowledged and then switches to the "Starting lockout" state. The "Starting lockout" state can be reset by applying an L signal to terminal 37. ¹⁾		

1) H signal: +13 to +33 V *
L signal: -33 to +3 V
or terminal open *

* for binary control inputs
8.5 mA at 24 V

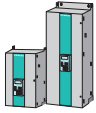

SIMOREG 6RA70 DC MASTER System Overview

Open-loop and closed-loop control section

Terminal assignments for CUD1

Type	Terminal design	Function	Terminal	Connection values/comments
Binary control outputs	Plug-in terminal (screw-terminal) Max. cross-section 1.5 mm ²	Ground M: – Binary selectable outputs	X171/47	<ul style="list-style-type: none"> • H signal: No fault ¹⁾ • L signal: Fault ¹⁾ Short-circuit-proof 100 mA ¹⁾
		– Binary selectable outputs	X171/54	
		Selectable output "Fault"	X171/46	
		Binary selectable output 2	X171/48	
		Relay for line contactor: – Common potential – NO contact	XR/109 XR/110	Short-circuit-proof 100 mA ¹⁾ Load rating: ≤ 250 V AC, 4 A; cos φ = 1 ≤ 250 V AC, 2 A; cos φ = 0.4 ≤ 30 V DC, 2 A
Serial interface 1 RS 232/X300 ²⁾ ³⁾ ⁴⁾		Housing earth	X300/1 ⁵⁾	
		Receive cable RS 232 standard (V.24)	X300/2 ⁵⁾	
		Send and receive cable two-wire RS 485, pos. diff. input/output	X300/4 ⁵⁾	
		$\overline{\text{BOOT}}$, control signal for software update	X300/4 ⁵⁾ ⁸⁾	
		Ground	X300/5 ⁵⁾	
		5 V voltage supply for OP1S	X300/6 ⁵⁾	
		Send cable RS 232 standard (V.24)	X300/7 ⁵⁾	
		Send and receive cable two-wire RS 485, neg. diff. input/output	X300/8 ⁵⁾	
		Ground	X300/9 ⁵⁾	
Serial interface 2 RS 485 ⁶⁾ ⁷⁾	Plug-in terminal (screw-terminal) Max. cross-section 1.5 mm ²	TX+	X172/56	RS 485, 4-wire send cable, positive differential input RS 485, 4-wire send cable, negative differential input RS 485, 4-wire receive cable, positive differential input, 2-wire send/receive cable, positive differential input RS 485, 4-wire receive cable, negative differen- tial input, 2-wire send/receive cable, negative differential input Ground
		TX-	X172/57	
		RX+/TX+	X172/58	
		RX-/TX-	X172/59	
		M X172/60		

2

1) H signal: +16 to +30 V
L signal: 0 to +2 V

2) 9-pin SUBMIN D socket

3) Cable length:
– Up to 15 m acc. to EIA
RS 232-C standard
– Up to 30 m capacitive load
max. 2.5 nF
(cable and receiver)

4) A serial connection to a PLC or
PC can be made using connector
X300 on the PMU. This allows the
converter to be controlled and
operated from a central control
center or room.

5) Connector pin

6) Cable length:
– For baud rate of = 187.5 kbd:
600 m
– For baud rate of ≤ 93.75 kbd:
1200 m

7) please observe DIN 19245 Part1.
In particular, the potential differ-
ence between the data reference
potentials M of all interfaces must

not exceed -7 V/+12 V. If this can-
not be guaranteed, then equipo-
tential bonding must be provided.

8) For SIMOREG 6RA70, no func-
tion.

SIMOREG 6RA70 DC MASTER

System Overview

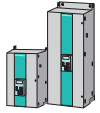

Block diagram

SIMOREG 6RA70, 15 A to 125 A without fan

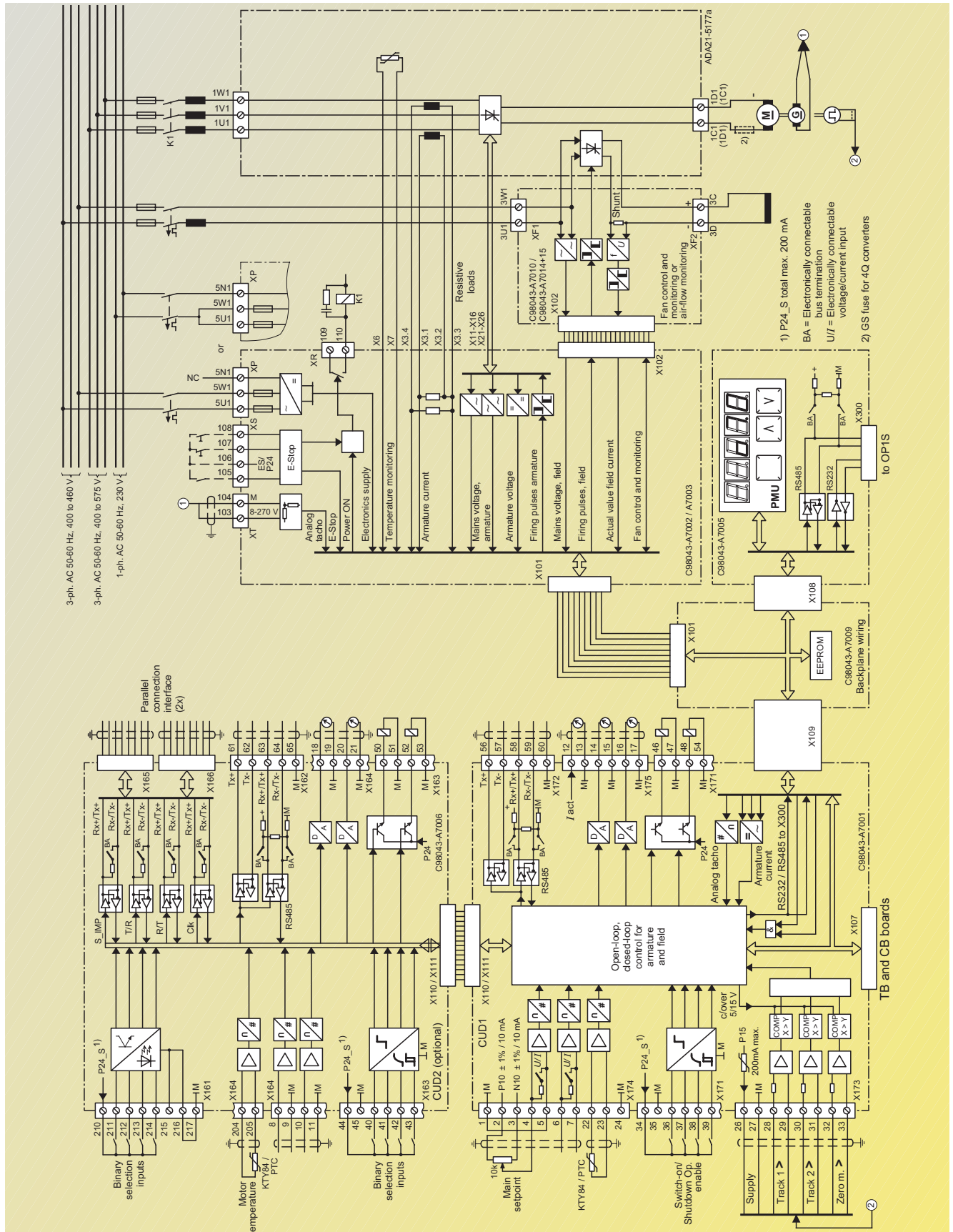
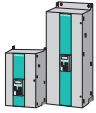

Fig. 2/9



SIMOREG 6RA70 DC MASTER System Overview

Block diagram

SIMOREG 6RA70 with fan

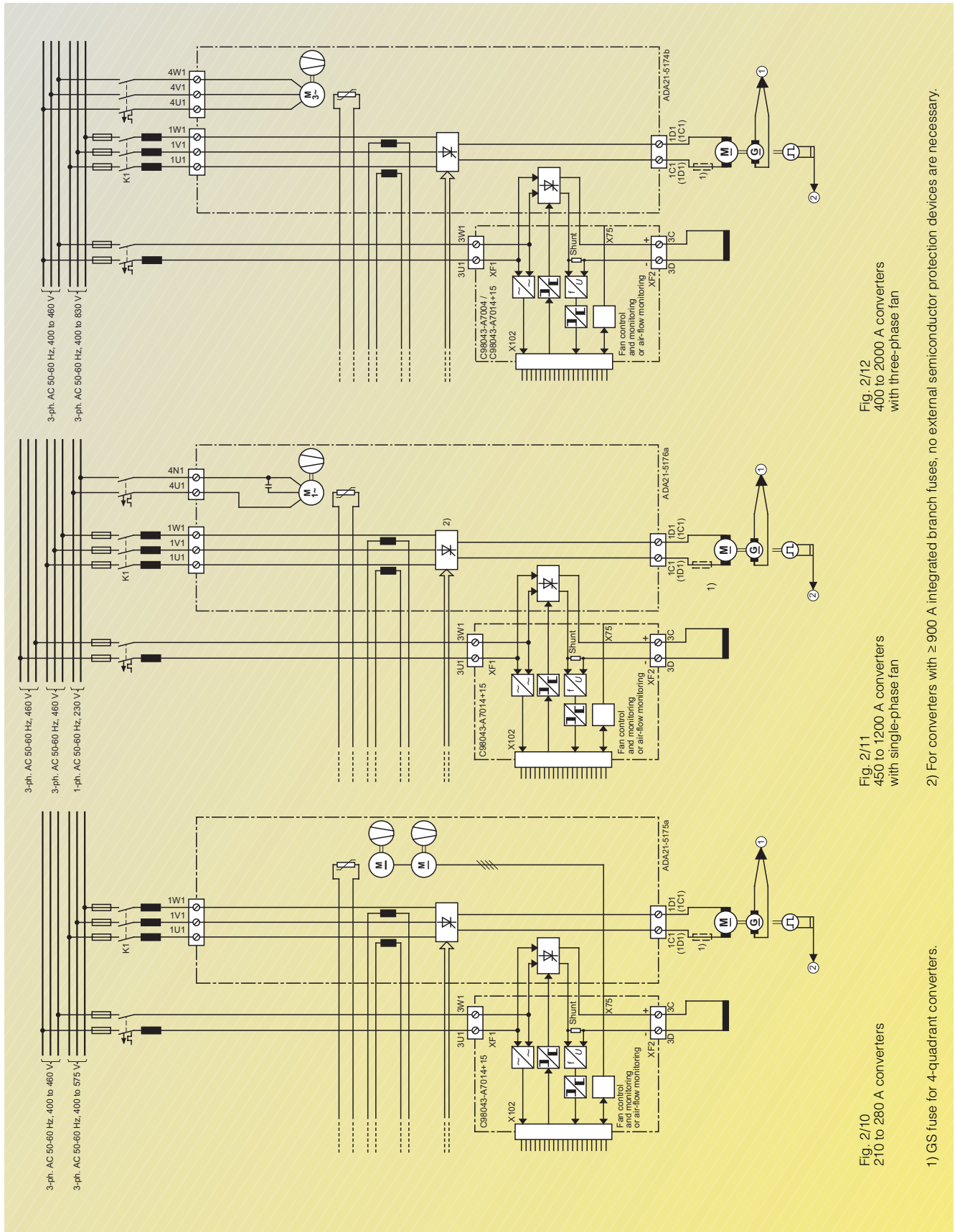

Fig. 2/10
210 to 280 A converters

Fig. 2/11
450 to 1200 A converters
with single-phase fan

Fig. 2/12
400 to 2000 A converters
with three-phase fan

1) GS fuse for 4-quadrant converters.
2) For converters with ≥ 900 A integrated branch fuses, no external semiconductor protection devices are necessary.

SIMOREG 6RA70 DC MASTER

System Overview

Notes

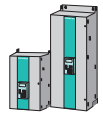

2

SIMOREG 6RA70 DC MASTER

Technical Data



3/2

General technical data

Converters for single-quadrant operation

3/3	3-ph. AC 400 V, 30 A to 125 A
3/4	3-ph. AC 400 V, 210 A to 600 A
3/5	3-ph. AC 400 V, 850 A to 2000 A
3/6	3-ph. AC 460 V, 30 A to 125 A
3/7	3-ph. AC 460 V, 210 A to 600 A
3/8	3-ph. AC 460 V, 850 A to 1200 A
3/9	3-ph. AC 575 V, 60 A to 600 A
3/10	3-ph. AC 575 V, 800 A to 2000 A
3/11	3-ph. AC 690 V, 720 A to 2000 A
3/12	3-ph. AC 830 V, 900 A to 1900 A

Converters for four-quadrant operation

3/13	3-ph. AC 400 V, 15 A to 125 A
3/14	3-ph. AC 400 V, 210 A to 600 A
3/15	3-ph. AC 400 V, 850 A to 2000 A
3/16	3-ph. AC 460 V, 30 A to 125 A
3/17	3-ph. AC 460 V, 210 A to 600 A
3/18	3-ph. AC 460 V, 850 A to 1200 A
3/19	3-ph. AC 575 V, 60 A to 600 A
3/20	3-ph. AC 575 V, 850 A to 2000 A
3/21	3-ph. AC 690 V, 760 A to 2000 A
3/22	3-ph. AC 830 V, 950 A to 1900 A

3

SIMOREG 6RA70 DC MASTER

Technical Data



Converters

General technical data

Type of cooling Converters ≤ 125 A rated armature current: Permissible ambient air temperature during operation Converters ≥ 210 A rated armature current: Permissible ambient air temperature during operation Permissible ambient air temperature during storage and transport	Self-ventilated 0 °C to 45 °C (reduction curves apply for +45 °C < T < +60 °C, Page 3/3 onwards) Enhanced air cooling with installed fan 0 °C to 40 °C (reduction curves apply for +40 °C < T < +50 °C, Page 3/3 onwards) -25 °C to +70 °C
Installation altitude	≤ 1000 m above sea level (100 % load rating) > 1000 m to 5000 m above sea level (reduction curves: see detailed data for converters)
Control stability	$\Delta n = 0.006\%$ of the rated motor speed, valid for pulse encoder operation and digital setpoint $\Delta n = 0.1\%$ of the rated motor speed, valid for analog tachometer and analog setpoint ²⁾
Humidity class	Relative air humidity ≤ = 95 %, dewing not permissible ¹⁾
Climate class	Class 3K3 acc. to DIN IEC 60 721-3-3
Insulation	Pollution severity 2 acc. to DIN VDE 0110-1 (HD 625.1 S: 1996) Dewing not permissible
Oversvoltage category	Category III acc. to DIN VDE 0110-1 for power section and power supply Category II acc. to DIN VDE 0110-1 for electronics
Oversvoltage resistance	Class 1 acc. to DIN VDE 0160
Degree of protection	IP 00 acc. to EN 60 529
Safety class	Class I acc. to DIN VDE 0106, Part 1
Shock-hazard protection	Acc. to DIN VDE 0106 Part 100 (VBG4) and DIN VDE 0113 Part 5
RI suppression	No RI suppression acc. to EN 61 800-3
MTBF	> 200,000 h acc. to SN 29500
Mechanical rigidity	Acc. to DIN IEC 60 068-2-6
For stationary use constant amplitude: • of acceleration • of displacement For transport constant amplitude: • of displacement • of acceleration	0.075 mm in frequency range 10 Hz to 58 Hz 9.8 ms ⁻² (1 x g) in frequency range > 58 Hz to 500 Hz 3.5 mm in frequency range 5 Hz to 9 Hz 9.8 ms ⁻² (1 x g) in frequency range > 9 Hz to 500 Hz
Approvals	UL _C UL ³⁾ CSA ³⁾ UL File No.: E203250 Archive File Number: LR 21927, Project Number: 158535-1218407 ⁴⁾
Applicable standards	DIN VDE 0106 Part 100 DIN VDE 0110 Part 1 EN 60146-1-1 / DIN VDE 0558 T11 EN 50178 / DIN VDE 0160 EN 61800-3 EN 60068-2-6 acc. to degree of severity 12 (SN29010 Part 1) Protection against electric shock; location of actuators near live parts. Insulation coordination for electrical equipment in low-voltage installations. Semiconductor converters General requirements and line-commutated converters Regulations for the equipment of electrical power installations with electronic equipment. Variable-speed drives, Part 3, EMC product standard including special test procedures Mechanical stress

1) 75 % at 17 °C annual mean
95 % at 24 °C max.

2) Conditions:
The control stability (PI control) is referred to the rated motor speed and applies when the SIMOREG converter is warm. The following conditions are applicable:
 - Temperature changes of ±10 °K
 - Line voltage changes corresponding to +10% / -5% of the rated input voltage
 - Temperature coefficient of temperature-compensated tachogenerators 0.15 % per 10 °K (applies only to analog tachogenerator)
 - Constant setpoint (14-bit resolution)

3) Not for converters with 690 V and 830 V rated voltage.

4) Available soon – from October 2001.

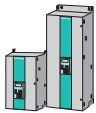

SIMOREG 6RA70 DC MASTER

Technical Data

Converters for single-quadrant operation

3-ph. AC 400 V, 30 A to 125 A, 1Q

Type	6RA70□□-6DS22				
	18	25	28	31	
Rated supply voltage armature ¹⁾	V	3-ph. AC 400 (+15 % / -20 %)			
Rated input current armature ²⁾	A	25	50	75	104
Rated supply voltage electronics supply	V	2-ph. AC 380 (-25 %) to 460 (+15 %); $I_N = 1$ A or 1-ph. AC 190 (-25 %) to 230 (+15 %); $I_N = 2$ A (-35 % for 1 min)			
Rated supply voltage field ¹⁾	V	2-ph. AC 400 (+15 % / -0%) ⁶⁾			
Rated frequency	Hz	45 to 65 ⁷⁾			
Rated DC voltage ¹⁾	V	485			
Rated DC current	A	30	60	90	125
Overload capability ⁵⁾		Max. 1.8 times rated DC current			
Rated output	kW	14.5	29	44	61
Power loss at rated DC current (approx.)	W	163	240	347	400
Rated DC voltage field ¹⁾	V	Max. 325			
Rated DC current field	A	5	10		
Operational ambient temperature	°C	0 to 45 at I_{rated} ³⁾ self-cooled			
Storage and transport temperature	°C	-25 to +70			
Installation altitude above sea level		≤ 1000 m at rated DC current ⁴⁾			
Dimensions (H x W x D)	mm	385 x 265 x 239	385 x 265 x 283		
See dimension drawing on Page		8/2			
Weight (approx.)	kg	11	14	16	16

3

1) The armature/field supply voltage can be less than the rated supply voltage armature/field (set with Parameter P078; for converters with 400 V rated voltage, input voltages of up to 85 V are permissible). The output voltage is reduced accordingly. The specified output DC voltage can be guaranteed up to undervoltages 5 % below the supply voltage (rated supply voltage armature/field).

2) Values apply to output rated DC current.

3) Load factor K1 (DC current) as a function of the coolant temperature (see P077 Operating Instructions, Section 11).
 $K1 > 1$ only permissible where $K1 * K2 \leq 1st$.
 overall reduction factor $K = K1 * K2$ (for K2 see Footnote 4).

Ambient or coolant temperature	Load factor K1	
	In devices with self-cooling	In devices with enhanced cooling
≤ +30 °C	1.18	1.10
+35 °C	1.12	1.05
+40 °C	1.06	1.00
+45 °C	1.00	0.95
+50 °C	0.94	0.90 ^{a)}
+55 °C	0.88	
+60 °C	0.82 ^{b)}	

a) In spite of derating, converters of ≥ 400 A with enhanced cooling may be operated at an ambient or coolant temperature of 50 °C only if the rated supply voltage of the converter fan is safely within the limited tolerance range of 400 V +10% -15%.

b) Not permissible when T400 or OP1S are used.

4) Load values K2 as a function of installation altitude (see P077 Operating Instructions, Section 11); overall reduction factor $K = K1 * K2$ (for K1 see Footnote 3).

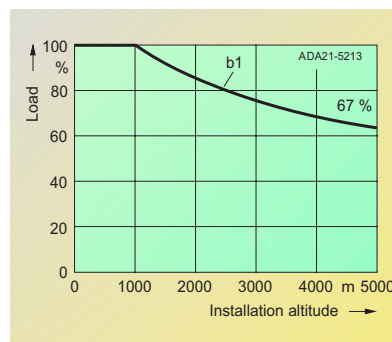

Curve b1: Reduction factor of load values (DC current) at installation altitudes above 1000 m.

Installation altitude m	1000	2000	3000	4000	5000
Reduction factor K2	1.0	0.835	0.74	0.71	0.67

The supply voltages for all electric circuits apply for site altitudes up to 5000 m for basic insulation, with the exception of converters for 830 V rated supply voltage:
 up to 4000 m 830 V
 up to 4500 m 795 V
 up to 5000 m 727 V

5) See Section 5.

6) 2-ph. AC 460 (+15% / -20%) is also permissible.

7) Operation in the extended frequency range of 23 Hz to 110 Hz is possible on request.

SIMOREG 6RA70 DC MASTER

Technical Data

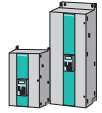

Converters for single-quadrant operation

3-ph. AC 400 V, 210 A to 600 A, 1Q

Type	6RA70□□-6DS22				
	75	78	81	85	
Rated supply voltage armature ¹⁾	V	3-ph. AC 400 (+15 % / -20 %)			
Rated input current armature ²⁾	A	175	233	332	498
Rated supply voltage electronics supply	V	2-ph. AC 380 (-25%) to 460 (+15%); $I_n=1$ A or 1-ph. AC 190 (-5%) to 230 (+15%); $I_n=2$ A (-35% for 1 min)			
Rated supply voltage fan	V	24 V DC internal		3-ph. AC 400 (±15%) 50 Hz 3-ph. AC 460 (±10%) 60 Hz	
Nominal fan current	A			0.3 ⁷⁾	
Air flow rate	m ³ /h	100		570	
Fan noise level	dBA	40		73	
Rated supply voltage field ¹⁾	V	2-ph. AC 400 (+15 % / -20%) ⁶⁾			
Rated frequency	Hz	45 to 65 ⁹⁾			
Rated DC voltage ¹⁾	V	485			
Rated DC current	A	210	280	400	600
Overload capability ⁵⁾		Max. 1.8 times rated DC current			
Rated output	kW	102	136	194	291
Power loss at rated DC current (approx.)	W	676	800	1328	1798
Rated DC voltage field ¹⁾	V	Max. 325			
Rated DC current field	A	15		25	
Operational ambient temperature	°C	0 to 40 at I_{rated} ³⁾ separately cooled			
Storage and transport temperature	°C	-25 to +70			
Installation altitude above sea level		≤ 1000 m at rated DC current ⁴⁾			
Dimensions (H x W x D)	mm	385 x 265 x 283		625 x 268 x 318	
See dimension drawing on Page		8/2		8/3	
Weight (approx.)	kg	16	17	30	

3

1) The armature/field supply voltage can be less than the rated supply voltage armature/field (set with Parameter P078; for converters with 400 V rated voltage, input voltages of up to 85 V are permissible). The output voltage is reduced accordingly. The specified output DC voltage can be guaranteed up to undervoltages 5 % below the supply voltage (rated supply voltage armature/field).

2) Values apply to output rated DC current.

3) Load factor K1 (DC current) as a function of the coolant temperature (see P077 Operating Instructions, Section 11).
K1 > 1 only permissible where $K1 * K2 \leq 1st.$
overall reduction factor $K = K1 * K2$
(for K2 see Footnote 4).

Ambient or coolant temperature	Load factor K1	
	In devices with self-cooling	In devices with enhanced cooling
≤ +30 °C	1.18	1.10
+35 °C	1.12	1.05
+40 °C	1.06	1.00
+45 °C	1.00	0.95
+50 °C	0.94	0.90 ^{a)}
+55 °C	0.88	
+60 °C	0.82 ^{b)}	

a) In spite of derating, converters of ≥ 400 A with enhanced cooling may be operated at an ambient or coolant temperature of 50 °C only if the rated supply voltage of the converter fan is safely within the limited tolerance range of 400 V +10% -15%.

b) Not permissible when T400 or OP1S are used.

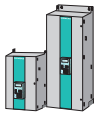

SIMOREG 6RA70 DC MASTER

Technical Data

Converters for single-quadrant operation

3-ph. AC 400 V, 850 A to 2000 A, 1Q

Type	6RA70□□-6DS22		6RA70□□-4DS22	
	87	91	93	95
Rated supply voltage armature ¹⁾	V 3-ph. AC 400 (+15% / -20%)			
Rated input current armature ²⁾	A 705	995	1326	1658
Rated supply voltage electronics supply	V 2-ph. AC 380 (-25%) to 460 (+15%); $I_n=1$ A or 1-ph. AC 190 (-25%) to 230 (+15%); $I_n=2$ A (-35% for 1 min)			
Rated supply voltage fan	V 3-ph. AC 400 (±15%) 50 Hz 3-ph. AC 460 (±10%) 60 Hz	3-ph. AC 400 (±10%) 50 Hz 3-ph. AC 460 (±10%) 60 Hz	3-ph. AC 400 (±10%) 50 Hz 3-ph. AC 460 (±10%) 60 Hz	3-ph. AC 400 (±10%) 50 Hz 3-ph. AC 460 (±10%) 60 Hz
Nominal fan current	A 0.3 ⁷⁾	1.0 ⁸⁾	1.25 ⁸⁾	1.25 ⁸⁾
Air flow rate	m ³ /h 570	1300	1300	2400
Fan noise level	dBA 73	83	87	83
Rated supply voltage field ¹⁾	V 2-ph. AC 400 (+15% / -20%) ⁶⁾			
Rated frequency	Hz 45 to 65 ⁹⁾			
Rated DC voltage ¹⁾	V 485			
Rated DC current	A 850	1200	1600	2000
Overload capability ⁵⁾	Max. 1.8 times rated DC current			
Rated output	kW 412	582	776	970
Power loss at rated DC current (approx.)	W 2420	4525	5710	6810
Rated DC voltage field ¹⁾	V Max. 325			
Rated DC current field	A 30		40	
Operational ambient temperature	°C 0 to 40 at I_{rated} ³⁾ separately cooled			
Storage and transport temperature	°C -25 to +70			
Installation altitude above sea level	≤ 1000 m at rated DC current ⁴⁾			
Dimensions (H x W x D)	mm 700 x 268 x 362	780 x 410 x 362	880 x 450 x 500	
See dimension drawing on Page	8/4		8/5	
Weight (approx.)	kg 40	80	125	

3

- 4) Load values K2 as a function of installation altitude (see P077 Operating Instructions, Section 11);
Overall reduction factor $K = K1 * K2$
(for K1 see Footnote 3).

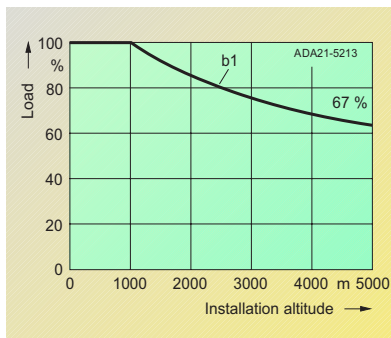

Curve b1: Reduction factor of load values (DC current) at installation altitudes above 1000 m.

Installation altitude m	1000	2000	3000	4000	5000
Reduction factor K2	1.0	0.835	0.74	0.71	0.67

The supply voltages for all electric circuits are possible for site altitudes up to 5000 m with basic insulation, with the exception of converters for 830 V rated supply voltage:
up to 4000 m 830 V
up to 4500 m 795 V
up to 5000 m 727 V

- 5) See Section 5.
6) 2-ph. AC 460 (+15% / -20%) is also permissible.
7) For UL systems, a Siemens motor protection circuit-breaker Type 3RV1011-0DA1 or 3RV1011-0EA1, adjusted to 0.3 A for the fan motor Type R2D220-AB02-19 must be installed in 6RA7081, 6RA7085 and 6RA7087 converters with a rated voltage of 400 V or 575 V.
8) For UL systems, a Siemens motor protection circuit-breaker Type 3RV1011-0KA1 or 3RV1011-1AA1, adjusted to 1.25 A for the fan motor Type RH28M-2DK.3F.1R must be installed in 6RA7090, 6RA7091, 6RA7093 and 6RA7095 converters with a rated voltage of 400 V or 575 V.
9) Operation in the extended frequency range of 23 Hz to 110 Hz is possible on request.

SIMOREG 6RA70 DC MASTER

Technical Data

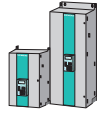

Converters for single-quadrant operation

3-ph. AC 460 V, 30 A to 125 A, 1Q

Type	6RA70□□-6FS22				
	18	25	28	31	
Rated supply voltage armature ¹⁾	V	3-ph. AC 460 (+15 % / -20 %)			
Rated input current armature ²⁾	A	25	50	75	104
Rated supply voltage electronics supply	V	2-ph. AC 380 (-25%) to 460 (+15%); $I_n=1$ A or 1-ph. AC 190 (-25%) to 230 (+15%); $I_n=2$ A (-35% for 1 min)			
Rated supply voltage field ¹⁾	V	2-ph. AC 460 (+15 % / -20 %)			
Rated frequency	Hz	45 to 65 ⁹⁾			
Rated DC voltage ¹⁾	V	550			
Rated DC current	A	30	60	90	125
Overload capability ⁵⁾		Max. 1.8 times rated DC current			
Rated output	kW	16.5	33	49.5	68.7
Power loss at rated DC current (approx.)	W	172	248	363	417
Rated DC voltage field ¹⁾	V	Max. 375			
Rated DC current field	A	5	10		
Operational ambient temperature	°C	0 to 45 at I_{rated} ³⁾ self-cooled			
Storage and transport temperature	°C	-25 to +70			
Installation altitude above sea level		≤ 1000 m at rated DC current ⁴⁾			
Dimensions (H x W x D)	mm	385 x 265 x 239	385 x 265 x 313		
See dimension drawing on Page		8/2	8/9		
Weight (approx.)	kg	11	15	17	17

3

1) The armature/field supply voltage can be less than the rated supply voltage armature/field (set with Parameter P078; for converters with 400 V rated voltage, input voltages of up to 85 V are permissible). The output voltage is reduced accordingly. The specified output DC voltage can be guaranteed up to undervoltages 5 % below the supply voltage (rated supply voltage armature/field).

2) Values apply to output rated DC current.

3) Load factor K1 (DC current) as a function of the coolant temperature (see P077 Operating Instructions, Section 11).
K1 > 1 only permissible where $K1 * K2 \leq 1st.$
overall reduction factor $K = K1 * K2$
(for K2 see Footnote 4).

Ambient or coolant temperature	Load factor K1	
	In devices with self-cooling	In devices with enhanced cooling
≤ +30 °C	1.18	1.10
+35 °C	1.12	1.05
+40 °C	1.06	1.00
+45 °C	1.00	0.95
+50 °C	0.94	0.90 ^{a)}
+55 °C	0.88	
+60 °C	0.82 ^{b)}	

a) In spite of derating, converters of ≥ 400 A with enhanced cooling may be operated at an ambient or coolant temperature of 50 °C only if the rated supply voltage of the converter fan is safely within the limited tolerance range of 400 V +10% -15%.

b) Not permissible when T400 or OP1S are used.

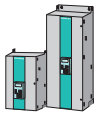

SIMOREG 6RA70 DC MASTER

Technical Data

Converters for single-quadrant operation

3-ph. AC 460 V, 210 A to 600 A, 1Q

Type	6RA70□□-6FS22			
	75	78	82	85
Rated supply voltage armature ¹⁾	V 3-ph. AC 460 (+15 % / -20 %)			
Rated input current armature ²⁾	A 175	233	374	498
Rated supply voltage electronics supply	V 2-ph. AC 380 (-25%) to 460 (+15%); $I_n=1$ A or 1-ph. AC 190 (-25%) to 230 (+15%); $I_n=2$ A (-35% for 1 min)			
Rated supply voltage fan	V 24 V DC internal		1-ph. AC 230 (±10%) 50 Hz 60 Hz	
Nominal fan current	A		0.55	0.55
Air flow rate	m ³ /h 100		570	570
Fan noise level	dBA 40		73	76
Rated supply voltage field ¹⁾	V 2-ph. AC 460 (+15 % / -20 %)			
Rated frequency	Hz 45 to 65 ⁹⁾			
Rated DC voltage ¹⁾	V 550			
Rated DC current	A 210	280	450	600
Overload capability ⁵⁾	Max. 1.8 times rated DC current			
Rated output	kW 115	154	247	330
Power loss at rated DC current (approx.)	W 700	792	1519	1845
Rated DC voltage field ¹⁾	V Max. 375			
Rated DC current field	A 15		25	
Operational ambient temperature	°C 0 to 40 at I_{rated} ³⁾ separately cooled			
Storage and transport temperature	°C -25 to +70			
Installation altitude above sea level	≤ 1000 m at rated DC current ⁴⁾			
Dimensions (H x W x D)	mm 385 x 265 x 313		625 x 268 x 318	
See dimension drawing on Page	8/9		8/10	
Weight (approx.)	kg 17	18	32	

3

4) Load values K2 as a function of installation altitude (see P077 Operating Instructions, Section 11);
Overall reduction factor $K = K1 * K2$
(for K1 see Footnote 3).

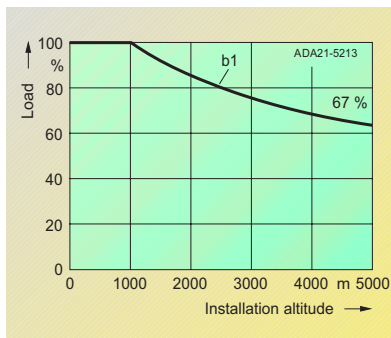

Curve b1: Reduction factor of load values (DC current) at installation altitudes above 1000 m.

Installation altitude m	1000	2000	3000	4000	5000
Reduction factor K2	1.0	0.835	0.74	0.71	0.67

The supply voltages for all electric circuits are possible for site altitudes up to 5000 m with basic insulation, with the exception of converters for 830 V rated supply voltage:
up to 4000 m 830 V
up to 4500 m 795 V
up to 5000 m 727 V

5) See Section 5.

9) Operation in the extended frequency range of 23 Hz to 110 Hz is possible on request.

SIMOREG 6RA70 DC MASTER

Technical Data



Converters for single-quadrant operation

3-ph. AC 460 V, 850 A to 1200 A, 1Q

Type	6RA70□□-6FS22			
	87		91	
Rated supply voltage armature ¹⁾	V	3-ph. AC 460 (+15 % / -20 %)		
Rated input current armature ²⁾	A	705		995
Rated supply voltage electronics supply	V	2-ph. AC 380 (-25%) to 460 (+15%); $I_n=1$ A or 1-ph. AC 190 (-25%) to 230 (+15%); $I_n=2$ A (-35% for 1 min)		
Rated supply voltage fan	V	1-ph. AC 230 (±10%) 50 Hz	60 Hz	1-ph. AC 230 (±10%) 50 Hz
Nominal fan current	A	0.55	0.55	2.6
Air flow rate	m ³ /h	570	570	1300
Fan noise level	dBA	73	76	82
Rated supply voltage field ¹⁾	V	2-ph. AC 460 (+15 % / -20 %)		
Rated frequency	Hz	45 to 65 ⁹⁾		
Rated DC voltage ¹⁾	V	550		
Rated DC current	A	850		1200
Overload capability ⁵⁾		Max. 1.8 times rated DC current		
Rated output	kW	467		660
Power loss at rated DC current (approx.)	W	2514		4620
Rated DC voltage field ¹⁾	V	Max. 375		
Rated DC current field	A	30		
Operational ambient temperature	°C	0 to 40 at I_{rated} ³⁾		
Storage and transport temperature	°C	-25 to +70		
Installation altitude above sea level		≤ 1000 m at rated DC current ⁴⁾		
Dimensions (H x W x D)	mm	700 x 268 x 362		780 x 410 x 362
See dimension drawing on Page		8/10		8/4
Weight (approx.)	kg	42		80

3

1) The armature/field supply voltage can be less than the rated supply voltage armature/field (set with Parameter P078; for converters with 400 V rated voltage, input voltages of up to 85 V are permissible). The output voltage is reduced accordingly. The specified output DC voltage can be guaranteed up to undervoltages 5 % below the supply voltage (rated supply voltage armature/field).

2) Values apply to output rated DC current.

3) Load factor K1 (DC current) as a function of the coolant temperature (see P077 Operating Instructions, Section 11).
K1 > 1 only permissible where $K1 * K2 \leq 1st.$
overall reduction factor $K = K1 * K2$
(for K2 see Footnote 4).

Ambient or coolant temperature	Load factor K1	
	In devices with self-cooling	In devices with enhanced cooling
≤ +30 °C	1.18	1.10
+35 °C	1.12	1.05
+40 °C	1.06	1.00
+45 °C	1.00	0.95
+50 °C	0.94	0.90 ^{a)}
+55 °C	0.88	
+60 °C	0.82 ^{b)}	

a) In spite of derating, converters of ≥ 400 A with enhanced cooling may be operated at an ambient or coolant temperature of 50 °C only if the rated supply voltage of the converter fan is safely within the limited tolerance range of 400 V +10% -15%.

b) Not permissible when T400 or OP1S are used.

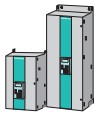

SIMOREG 6RA70 DC MASTER

Technical Data

Converters for single-quadrant operation

3-ph. AC 575 V, 60 A to 600 A, 1Q

Type	6RA70□□-6GS22				
	25	31	75	81	85
Rated supply voltage armature ¹⁾	V 3-ph. AC 575 (+10% / -20%)				
Rated input current armature ²⁾	A 50	104	175	332	498
Rated supply voltage electronics supply	V 2-ph. AC 380 (-25%) to 460 (+15%); $I_n=1$ A or 1-ph. AC 190 (-25%) to 230 (+15%); $I_n=2$ A (-35% for 1 min)				
Rated supply voltage fan	V		24 V DC internal	3-ph. AC 400 (±15%) 50 Hz 3-ph. AC 460 (±10%) 60 Hz	
Nominal fan current	A			0.3 ⁸⁾	
Air flow rate	m ³ /h		100	570	
Fan noise level	dBA		40	73	
Rated supply voltage field ¹⁾	V 2-ph. AC 460 (+15% / -20%)				
Rated frequency	Hz 45 to 65 ⁹⁾				
Rated DC voltage ¹⁾	V 690				
Rated DC current	A 60	125	210	400	600
Overload capability ⁵⁾	Max. 1.8 times rated DC current				
Rated output	kW 41	86	145	276	414
Power loss at rated DC current (approx.)	W 265	454	730	1550	1955
Rated DC voltage field ¹⁾	V Max. 375				
Rated DC current field	A 10		15	25	
Operational ambient temperature	°C 0 to 45 at I_{rated} ³⁾ self-cooled		0 to 40 at I_{rated} ³⁾ separately cooled		
Storage and transport temperature	°C -25 to +70				
Installation altitude above sea level	≤ 1000 m at rated DC current ⁴⁾				
Dimensions (H x W x D)	mm 385 x 265 x 283			625 x 268 x 318	
See dimension drawing on Page	8/2			8/3	
Weight (approx.)	kg 14	16	30		

3

- 4) Load values K2 as a function of the installation altitude (see P077 Operating Instructions, Section 11);
Overall reduction factor $K = K_1 * K_2$
(for K_1 see Footnote 3)

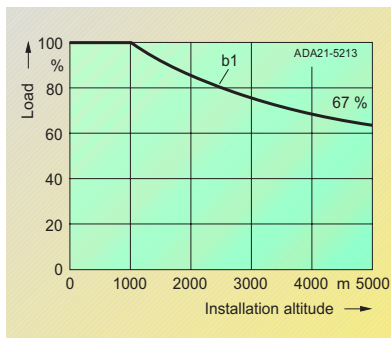

Curve b1: Reduction factor of load values (DC current) at installation altitudes above 1000 m.

Installation altitude m	1000	2000	3000	4000	5000
Reduction factor K2	1.0	0.835	0.74	0.71	0.67

The supply voltages for all electric circuits are possible for site altitudes up to 5000 m with basic insulation, with the exception of converters for 830 V rated supply voltage:
up to 4000 m 830 V
up to 4500 m 795 V
up to 5000 m 727 V

- 5) See Section 5.

- 9) Operation in the extended frequency range of 23 Hz to 110 Hz is possible on request.

SIMOREG 6RA70 DC MASTER

Technical Data

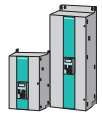

Converters for single-quadrant operation

3-ph. AC 575 V, 800 A to 2000 A, 1Q

Type	6RA70□□-6GS22			6RA70□□-4GS22	
	87	90	93	95	
Rated supply voltage armature ¹⁾	V 3-ph. AC 575 (+10% / -20%)				
Rated input current armature ²⁾	A 663	829	1326	1658	
Rated supply voltage electronics supply	V 2-ph. AC 380 (-25%) to 460 (+15%); $I_n=1$ A or 1-ph. AC 190 (-25%) to 230 (+15%); $I_n=2$ A (-35% for 1 min)				
Rated supply voltage fan	V 3-ph. AC 400 (±15%) 50 Hz 3-ph. AC 460 (±10%) 60 Hz		3-ph. AC 400 (±10%) 50 Hz 3-ph. AC 460 (±10%) 60 Hz		3-ph. AC 400 (±10%) 50 Hz 3-ph. AC 460 (±10%) 60 Hz
Nominal fan current	A 0.3 ⁷⁾	1.0 ⁸⁾	1.25 ⁸⁾	1.0 ⁸⁾	1.25 ⁸⁾
Air flow rate	m ³ /h 570	1300	1300	2400	2400
Fan noise level	dBA 73	83	87	83	87
Rated supply voltage field ¹⁾	V 2-ph. AC 460 (+15% / -20%)				
Rated frequency	Hz 45 to 65 ⁹⁾				
Rated DC voltage ¹⁾	V 690				
Rated DC current	A 800	1000	1600	2000	
Overload capability ⁵⁾	Max. 1.8 times rated DC current				
Rated output	kW 552	690	1104	1380	
Power loss at rated DC current (approx.)	W 2638	4130	5942	7349	
Rated DC voltage field ¹⁾	V Max. 375				
Rated DC current field	A 30			40	
Operational ambient temperature	°C 0 to 40 at I_{rated} ³⁾ separately cooled				
Storage and transport temperature	°C -25 to +70				
Installation altitude above sea level	≤ 1000 m at rated DC current ⁴⁾				
Dimensions (H x W x D)	mm 700 x 268 x 362	780 x 410 x 362	880 x 450 x 500		
See dimension drawing on Page	8/4		8/5		
Weight (approx.)	kg 40	80	125		

1) The armature/field supply voltage can be less than the rated supply voltage armature/field (set with Parameter P078; for converters with 400 V rated voltage, input voltages of up to 85 V are permissible). The output voltage is reduced accordingly. The specified output DC voltage can be guaranteed up to undervoltages 5 % below the supply voltage (rated supply voltage armature/field).

2) Values apply to output rated DC current.

3) Load factor K1 (DC current) as a function of the coolant temperature (see P077 Operating Instructions, Section 11).
K1 > 1 only permissible where $K1 * K2 \leq 1st.$
overall reduction factor $K = K1 * K2$
(for K2 see Footnote 4).

Ambient or coolant temperature	Load factor K1	
	In devices with self-cooling	In devices with enhanced cooling
≤ +30 °C	1.18	1.10
+35 °C	1.12	1.05
+40 °C	1.06	1.00
+45 °C	1.00	0.95
+50 °C	0.94	0.90 ^{a)}
+55 °C	0.88	
+60 °C	0.82 ^{b)}	

a) In spite of derating, converters of ≥ 400 A with enhanced cooling may be operated at an ambient or coolant temperature of 50 °C only if the rated supply voltage of the converter fan is safely within the limited tolerance range of 400 V +10% -15%.

b) Not permissible when T400 or OP1S are used.

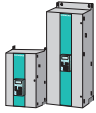

SIMOREG 6RA70 DC MASTER

Technical Data

Converters for single-quadrant operation

3-ph. AC 690 V, 720 A to 2000 A, 1Q

Type	6RA70□□-6KS22			6RA70□□-4KS22	
	86	88		93	95
Rated supply voltage armature ¹⁾	V 3-ph. AC 690 (+10% / -20%)				
Rated input current armature ²⁾	A 597	788		1244	1658
Rated supply voltage electronics supply	V 2-ph. AC 380 (-25%) to 460 (+15%); $I_n=1$ A or 1-ph. AC 190 (-25%) to 230 (+15%); $I_n=2$ A (-35% for 1 min)				
Rated supply voltage fan	V 3-ph. AC 400 (±15%) 50 Hz 3-ph. AC 460 (±10%) 60 Hz		3-ph. AC 400 (±10%) 50 Hz 3-ph. AC 460 (±10%) 60 Hz		3-ph. AC 400 (±10%) 50 Hz 3-ph. AC 460 (±10%) 60 Hz
Nominal fan current	A 0.3 ⁷⁾	1.0 ⁸⁾	1.25 ⁸⁾	1.0 ⁸⁾	1.25 ⁸⁾
Air flow rate	m ³ /h 570	1300	1300	2400	2400
Fan noise level	dBA 73	83	87	83	87
Rated supply voltage field ¹⁾	V 2-ph. AC 460 (+15% / -20%)				
Rated frequency	Hz 45 to 65 ⁹⁾				
Rated DC voltage ¹⁾	V 830				
Rated DC current	A 720	950		1500	2000
Overload capability ⁵⁾	Max. 1.8 times rated DC current				
Rated output	kW 598	789		1245	1660
Power loss at rated DC current (approx.)	W 2720	4380		6706	8190
Rated DC voltage field ¹⁾	V Max. 375				
Rated DC current field	A 30			40	
Operational ambient temperature	°C 0 to 40 at I_{rated} ³⁾ separately cooled				
Storage and transport temperature	°C -25 to +70				
Installation altitude above sea level	≤ 1000 m at rated DC current ⁴⁾				
Dimensions (H x W x D)	mm 700 x 268 x 362	780 x 410 x 362		880 x 450 x 500	
See dimension drawing on Page	8/4			8/5	
Weight (approx.)	kg 40	80		125	

3

- 4) Load values K2 as a function of the installation altitude (see P077 Operating Instructions, Section 11); Overall reduction factor $K = K1 * K2$ (for K1 see Footnote 3).

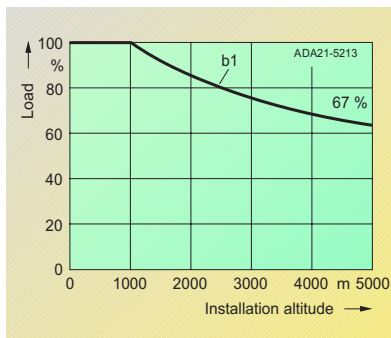

Curve b1: Reduction factor of load values (DC current) at installation altitudes above 1000 m.

Installation altitude m	1000	2000	3000	4000	5000
Reduction factor K2	1.0	0.835	0.74	0.71	0.67

The supply voltages for all electric circuits are possible for site altitudes up to 5000 m with basic insulation, With the exception of converters for 830 V rated supply voltage:
 up to 4000 m 830 V
 up to 4500 m 795 V
 up to 5000 m 727 V

- 5) See Section 5.
 6) 2-ph. AC 460 (+15% / -20%) is also permissible.
 7) For UL systems, a Siemens motor protection circuit-breaker Type 3RV1011-0DA1 or 3RV1011-0EA1, adjusted to 0.3 A for the fan motor Type R2D220-AB02-19 must be installed in 6RA7081, 6RA7085 and 6RA7087 converters with a rated voltage of 400 V or 575 V.
 8) For UL systems, a Siemens motor protection circuit-breaker Type 3RV1011-0KA1 or 3RV1011-1AA1, adjusted to 1.25 A for the fan motor Type RH28M-2DK.3F.1R must be installed in 6RA7090, 6RA7091, 6RA7093 and 6RA7095 converters with a rated voltage of 400 V or 575 V.
 9) Operation in the extended frequency range of 23 Hz to 110 Hz is possible on request.

SIMOREG 6RA70 DC MASTER

Technical Data

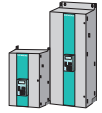

Converters for single-quadrant operation

3-ph. AC 830 V, 900 A to 1900 A, 1Q

Type	6RA70□□-6LS22		6RA70□□-4LS22		
		88	93	95	
Rated supply voltage armature ¹⁾	V	3-ph. AC 830 (+10% / -20%)			
Rated input current armature ²⁾	A	746	1244	1575	
Rated supply voltage electronics supply	V	2-ph. AC 380 (-25%) to 460 (+15%); $I_n=1$ A or 1-ph. AC 190 (-25%) to 230 (+15%); $I_n=2$ A (-35% for 1 min)			
Rated supply voltage fan	V	3-ph. AC 400 (±10%) 50 Hz	3-ph. AC 400 (±10%) 50 Hz		
		3-ph. AC 460 (±10%) 60 Hz	3-ph. AC 460 (±10%) 60 Hz		
Nominal fan current	A	50 Hz	60 Hz	50 Hz	60 Hz
		1.0 ⁸⁾	1.25 ⁸⁾	1.0 ⁸⁾	1.25 ⁸⁾
Air flow rate	m ³ /h	1300	1300	2400	2400
Fan noise level	dBA	83	87	83	87
Rated supply voltage field ¹⁾	V	2-ph. AC 460 (+15% / -20%)			
Rated frequency	Hz	45 to 65 ⁹⁾			
Rated DC voltage ¹⁾	V	1000			
Rated DC current	A	900	1500	1900	
Overload capability ⁵⁾		Max. 1.8 times rated DC current			
Rated output	kW	900	1500	1900	
Power loss at rated DC current (approx.)	W	4638	6778	8700	
Rated DC voltage field ¹⁾	V	Max. 375			
Rated DC current field	A	30	40		
Operational ambient temperature	°C	0 to 40 at I_{rated} ³⁾ separately cooled			
Storage and transport temperature	°C	-25 to +70			
Installation altitude above sea level		≤ 1000 m at rated DC current ⁴⁾			
Dimensions (H x W x D)	mm	780 x 410 x 362	880 x 450 x 500		
See dimension drawing on Page		8/4	8/5		
Weight (approx.)	kg	80	125		

3

1) The armature/field supply voltage can be less than the rated supply voltage armature/field (set with Parameter P078; for converters with 400 V rated voltage, input voltages of up to 85 V are permissible). The output voltage is reduced accordingly. The specified output DC voltage can be guaranteed up to undervoltages 5 % below the supply voltage (rated supply voltage armature/field).

2) Values apply to output rated DC current.

3) Load factor K1 (DC current) as a function of the coolant temperature (see P077 Operating Instructions, Section 11).
K1 > 1 only permissible where $K1 * K2 \leq 1st.$
overall reduction factor $K = K1 * K2$
(for K2 see Footnote 4).

Ambient or coolant temperature	Load factor K1	
	In devices with self-cooling	In devices with enhanced cooling
≤ +30 °C	1.18	1.10
+35 °C	1.12	1.05
+40 °C	1.06	1.00
+45 °C	1.00	0.95
+50 °C	0.94	0.90 ^{a)}
+55 °C	0.88	
+60 °C	0.82 ^{b)}	

a) In spite of derating, converters of ≥ 400 A with enhanced cooling may be operated at an ambient or coolant temperature of 50 °C only if the rated supply voltage of the converter fan is safely within the limited tolerance range of 400 V +10% -15%.

b) Not permissible when T400 or OP1S are used.

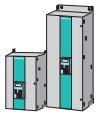

SIMOREG 6RA70 DC MASTER

Technical Data

Converters for four-quadrant operation

3-ph. AC 400 V, 15 A to 125 A, 4Q

Type	6RA70□□-6DV62				
	13	18	25	28	31
Rated supply voltage armature ¹⁾	V 3-ph. AC 400 (+15 % / -20 %)				
Rated input current armature ²⁾	A 13	25	50	75	104
Rated supply voltage electronics supply	V 2-ph. AC 380 (-25 %) to 460 (+15 %); $I_n = 1$ A or 1-ph. AC 190 (-25 %) to 230 (+15 %); $I_n = 2$ A (-35 % for 1 min)				
Rated supply voltage field ¹⁾	V 2-ph. AC 400 (+15 % / -20%) ⁶⁾				
Rated frequency	Hz 45 to 65 ⁹⁾				
Rated DC voltage ¹⁾	V 420				
Rated DC current	A 15	30	60	90	125
Overload capability ⁵⁾	Max. 1.8 times rated DC current				
Rated output	kW 6.3	12.6	25	38	52.5
Power loss at rated DC current (approx.)	W 117	163	240	312	400
Rated DC voltage field ¹⁾	V Max. 325				
Rated DC current field	A 3	5	10		
Operational ambient temperature	°C 0 to 45 at I_{rated} ³⁾ self-cooled				
Storage and transport temperature	°C -25 to +70				
Installation altitude above sea level	≤ 1000 m at rated DC current ⁴⁾				
Dimensions (H x W x D)	mm 385 x 265 x 239		385 x 265 x 283		
See dimension drawing on Page	8/6				
Weight (approx.)	kg 11	11	14	14	16

3

- 4) Load values K2 as a function of installation altitude (see P077 Operating Instructions, Section 11);
Overall reduction factor $K = K1 * K2$
(for K1 see Footnote 3).

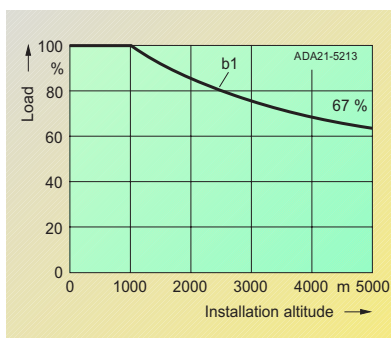

Curve b1: Reduction factor of load values (DC current) at installation altitudes above 1000 m.

Installation altitude m	1000	2000	3000	4000	5000
Reduction factor K2	1.0	0.835	0.74	0.71	0.67

The supply voltages for all electric circuits are possible for site altitudes up to 5000 m with basic insulation, with the exception of converters for 830 V rated supply voltage:
up to 4000 m 830 V
up to 4500 m 795 V
up to 5000 m 727 V

- 5) See Section 5.
6) 2-ph. AC 460 (+15% / -20%) is also permissible.
8) For UL systems, a Siemens motor protection circuit-breaker Type 3RV1011-0KA1 or 3RV1011-1AA1, adjusted to 1.25 A for the fan motor Type RH28M-2DK.3F.1R must be installed in 6RA7090, 6RA7091, 6RA7093 and 6RA7095 converters with a rated voltage of 400 V or 575 V.
9) Operation in the extended frequency range of 23 Hz to 110 Hz is possible on request.

SIMOREG 6RA70 DC MASTER

Technical Data

Converters for four-quadrant operation



3-ph. AC 400 V, 210 A to 600 A, 4Q

Type	6RA70□□□-6DV62				
	75	78	81	85	
Rated supply voltage armature ¹⁾	V	3-ph. AC 400 (+15 % / -20 %)			
Rated input current armature ²⁾	A	175	233	332	498
Rated supply voltage electronics supply	V	2-ph. AC 380 (-25%) to 460 (+15%); $I_n=1$ A or 1-ph. AC 190 (-25%) to 230 (+15%); $I_n=2$ A (-35% for 1 min)			
Rated supply voltage fan	V	24 V DC internal		3-ph. AC 400 (±15%) 50 Hz 3-ph. AC 460 (±10%) 60 Hz	
Nominal fan current	A			0.3 ⁷⁾	
Air flow rate	m ³ /h	100		570	
Fan noise level	dBA	40		73	
Rated supply voltage field ¹⁾	V	2-ph. AC 400 (+15 % / -20%) ⁶⁾			
Rated frequency	Hz	45 to 65 ⁹⁾			
Rated DC voltage ¹⁾	V	420			
Rated DC current	A	210	280	400	600
Overload capability ⁵⁾		Max. 1.8 times rated DC current			
Rated output	kW	88	118	168	252
Power loss at rated DC current (approx.)	W	676	800	1328	1800
Rated DC voltage field ¹⁾	V	Max. 325			
Rated DC current field	A	15		25	
Operational ambient temperature	°C	0 to 40 at I_{rated} ³⁾ separately cooled			
Storage and transport temperature	°C	-25 to +70			
Installation altitude above sea level		≤ 1000 m at rated DC current ⁴⁾			
Dimensions (H x W x D)	mm	385 x 265 x 283		625 x 268 x 318	
See dimension drawing on Page		8/6		8/7	
Weight (approx.)	kg	16	17	30	

3

1) The armature/field supply voltage can be less than the rated supply voltage armature/field (set with Parameter P078; for converters with 400 V rated voltage, input voltages of up to 85 V are permissible). The output voltage is reduced accordingly. The specified output DC voltage can be guaranteed up to undervoltages 5 % below the supply voltage (rated supply voltage armature/field).

2) Values apply to output rated DC current.

3) Load factor K1 (DC current) as a function of the coolant temperature (see P077 Operating Instructions, Section 11).
K1 > 1 only permissible where $K1 * K2 \leq 1st.$
overall reduction factor $K = K1 * K2$
(for K2 see Footnote 4).

Ambient or coolant temperature	Load factor K1	
	In devices with self-cooling	In devices with enhanced cooling
≤ +30 °C	1.18	1.10
+35 °C	1.12	1.05
+40 °C	1.06	1.00
+45 °C	1.00	0.95
+50 °C	0.94	0.90 ^{a)}
+55 °C	0.88	
+60 °C	0.82 ^{b)}	

a) In spite of derating, converters of ≥ 400 A with enhanced cooling may be operated at an ambient or coolant temperature of 50 °C only if the rated supply voltage of the converter fan is safely within the limited tolerance range of 400 V +10% -15%.

b) Not permissible when T400 or OP1S are used.

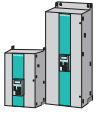

SIMOREG 6RA70 DC MASTER

Technical Data

Converters for four-quadrant operation

3-ph. AC 400 V, 850 A to 2000 A, 4Q

Type	6RA70□□-6DV62			6RA70□□-4DV62	
	87	91	93	95	
Rated supply voltage armature ¹⁾	V 3-ph. AC 400 (+15% / -20%)				
Rated input current armature ²⁾	A 705	995	1326	1658	
Rated supply voltage electronics supply	V 2-ph. AC 380 (-25%) to 460 (+15%); $I_n=1$ A or 1-ph. AC 190 (-25%) to 230 (+15%); $I_n=2$ A (-35% for 1 min)				
Rated supply voltage fan	V 3-ph. AC 400 (±15%) 50 Hz 3-ph. AC 460 (±10%) 60 Hz		3-ph. AC 400 (±10%) 50 Hz 3-ph. AC 460 (±10%) 60 Hz		3-ph. AC 400 (±10%) 50 Hz 3-ph. AC 460 (±10%) 60 Hz
Nominal fan current	A 0.3 ⁷⁾	1.0 ⁸⁾	1.25 ⁸⁾	1.0 ⁸⁾	1.25 ⁸⁾
Air flow rate	m ³ /h 570	1300	1300	2400	2400
Fan noise level	dBA 73	83	87	83	87
Rated supply voltage field ¹⁾	V 2-ph. AC 400 (+15% / -0%) ⁶⁾				
Rated frequency	Hz 45 to 65 ⁹⁾				
Rated DC voltage ¹⁾	V 420				
Rated DC current	A 850	1200	1600	2000	
Overload capability ⁵⁾	Max. 1.8 times rated DC current				
Rated output	kW 357	504	672	840	
Power loss at rated DC current (approx.)	W 2420	4525	5708	6810	
Rated DC voltage field ¹⁾	V Max. 325				
Rated DC current field	A 30			40	
Operational ambient temperature	°C 0 to 40 at I_{rated} ³⁾ separately cooled				
Storage and transport temperature	°C -25 to +70				
Installation altitude above sea level	≤ 1000 m at rated DC current ⁴⁾				
Dimensions (H x W x D)	mm 700 x 268 x 362	780 x 410 x 362	880 x 450 x 500		
See dimension drawing on Page	8/7	8/8			
Weight (approx.)	kg 45	85	145		

3

4) Load values K2 as a function of the installation altitude (see P077 Operating Instructions, Section 11); Overall reduction factor $K = K1 * K2$ (for K1 see Footnote 3).

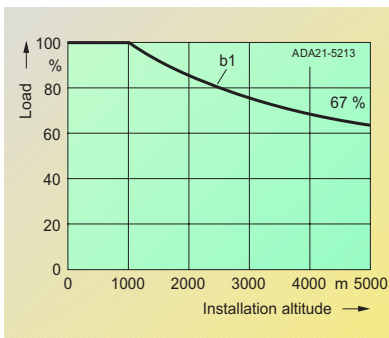

Curve b1: Reduction factor of load values (DC current) at installation altitudes above 1000 m.

Installation altitude m	1000	2000	3000	4000	5000
Reduction factor K2	1.0	0.835	0.74	0.71	0.67

The supply voltages for all electric circuits are possible for site altitudes up to 5000 m with basic insulation, with the exception of converters for 830 V rated supply voltage:
 up to 4000 m 830 V
 up to 4500 m 795 V
 up to 5000 m 727 V

5) See Section 5.

6) 2-ph. AC 460 (+15% / -20%) is also permissible.

7) For UL systems, a Siemens motor protection circuit-breaker Type 3RV1011-0DA1 or 3RV1011-0EA1, adjusted to 0.3 A for the fan motor Type R2D220-AB02-19 must be installed in 6RA7081, 6RA7085 and 6RA7087 converters with a rated voltage of 400 V or 575 V.

8) For UL systems, a Siemens motor protection circuit-breaker Type 3RV1011-0KA1 or 3RV1011-1AA1, adjusted to 1.25 A for the fan motor Type RH28M-2DK.3F.1R must be installed in 6RA7090, 6RA7091, 6RA7093 and 6RA7095 converters with a rated voltage of 400 V or 575 V.

9) Operation in the extended frequency range of 23 Hz to 110 Hz is possible on request.

SIMOREG 6RA70 DC MASTER

Technical Data

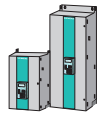

Converters for four-quadrant operation

3-ph. AC 460 V, 30 A to 125 A, 4Q

Type	6RA70□□-6FV62			
	18	25	28	31
Rated supply voltage armature ¹⁾	V 3-ph. AC 460 (+15 % / -20 %)			
Rated input current armature ²⁾	A 25	50	75	104
Rated supply voltage electronics supply	V 2-ph. AC 380 (-25 %) to 460 (+15 %); I _n = 1 A or 1-ph. AC 190 (-25 %) to 230 (+15 %); I _n = 2 A (-35 % for 1 min)			
Rated supply voltage field ¹⁾	V 2-ph. AC 460 (+15 % / -20 %)			
Rated frequency	Hz 45 to 65 ⁹⁾			
Rated DC voltage ¹⁾	V 480			
Rated DC current	A 30	60	90	125
Overload capability ⁵⁾	Max. 1.8 times rated DC current			
Rated output	kW 14.4	28.8	43	60
Power loss at rated DC current (approx.)	W 172	248	328	417
Rated DC voltage field ¹⁾	V Max. 375			
Rated DC current field	A 5	10		
Operational ambient temperature	°C 0 to 45 at I _{rated} ³⁾ self-cooled			
Storage and transport temperature	°C -25 to +70			
Installation altitude above sea level	≤ 1000 m at rated DC current ⁴⁾			
Dimensions (H x W x D)	mm 385 x 265 x 239	385 x 265 x 313		
See dimension drawing on Page	8/6	8/11		
Weight (approx.)	kg 11	15	15	17

1) The armature/field supply voltage can be less than the rated supply voltage armature/field (set with Parameter P078; for converters with 400 V rated voltage, input voltages of up to 85 V are permissible). The output voltage is reduced accordingly. The specified output DC voltage can be guaranteed up to undervoltages 5 % below the supply voltage (rated supply voltage armature/field).

2) Values apply to output rated DC current.

3) Load factor K1 (DC current) as a function of the coolant temperature (see P077 Operating Instructions, Section 11).
K1 > 1 only permissible where K1 * K2 ≤ 1st. overall reduction factor K = K1 * K2 (for K2 see Footnote 4).

Ambient or coolant temperature	Load factor K1	
	In devices with self-cooling	In devices with enhanced cooling
≤ +30 °C	1.18	1.10
+35 °C	1.12	1.05
+40 °C	1.06	1.00
+45 °C	1.00	0.95
+50 °C	0.94	0.90 ^{a)}
+55 °C	0.88	
+60 °C	0.82 ^{b)}	

a) In spite of derating, converters of ≥ 400 A with enhanced cooling may be operated at an ambient or coolant temperature of 50 °C only if the rated supply voltage of the converter fan is safely within the limited tolerance range of 400 V +10% -15%.

b) Not permissible when T400 or OP1S are used.

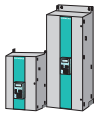

SIMOREG 6RA70 DC MASTER

Technical Data

Converters for four-quadrant operation

3-ph. AC 460 V, 210 A to 600 A, 4Q

Type	6RA70□□-6FV62			
	75	78	82	85
Rated supply voltage armature ¹⁾	V 3-ph. AC 460 (+15 % / -20 %)			
Rated input current armature ²⁾	A 175	233	374	498
Rated supply voltage electronics supply	V 2-ph. AC 380 (-25%) to 460 (+15%); $I_n=1$ A or 1-ph. AC 190 (-25%) to 230 (+15%); $I_n=2$ A (-35% for 1 min)			
Rated supply voltage fan	V 24 V DC internal		1-ph. AC 230 (±10%)	
Nominal fan current	A		0.55	0.55
Air flow rate	m ³ /h 100		570	570
Fan noise level	dBA 40		73	76
Rated supply voltage field ¹⁾	V 2-ph. AC 460 (+15 % / -20 %)			
Rated frequency	Hz 45 to 65 ⁹⁾			
Rated DC voltage ¹⁾	V 480			
Rated DC current	A 210	280	450	600
Overload capability ⁵⁾	Max. 1.8 times rated DC current			
Rated output	kW 100	134	216	288
Power loss at rated DC current (approx.)	W 700	792	1519	1845
Rated DC voltage field ¹⁾	V Max. 375			
Rated DC current field	A 15		25	
Operational ambient temperature	°C 0 to 40 at I_{rated} ³⁾ separately cooled			
Storage and transport temperature	°C -25 to +70			
Installation altitude above sea level	≤ 1000 m at rated DC current ⁴⁾			
Dimensions (H x W x D)	mm 385 x 265 x 313		625 x 268 x 318	
See dimension drawing on Page	8/11		8/12	
Weight (approx.)	kg 17	18	32	

3

4) Load values K2 as a function of the installation altitude (see P077 Operating Instructions, Section 11);
Overall reduction factor $K = K1 * K2$
(for K1 see Footnote 3).

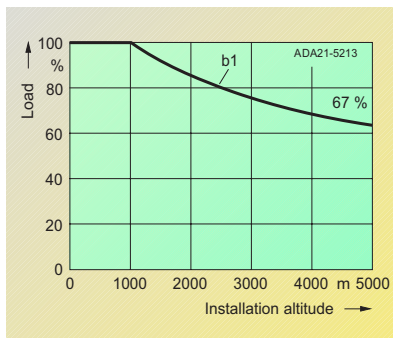

Curve b1: Reduction factor of load values (DC current) at installation altitudes above 1000 m.

Installation altitude m	1000	2000	3000	4000	5000
Reduction factor K2	1.0	0.835	0.74	0.71	0.67

The supply voltages for all electric circuits are possible for site altitudes up to 5000 m with basic insulation, with the exception of converters for 830 V rated supply voltage:
up to 4000 m 830 V
up to 4500 m 795 V
up to 5000 m 727 V

5) See Section 5.

9) Operation in the extended frequency range of 23 Hz to 110 Hz is possible on request.

SIMOREG 6RA70 DC MASTER

Technical Data

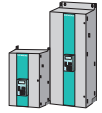

Converters for four-quadrant operation

3-ph. AC 460 V, 850 A to 1200 A, 4Q

Type	6RA70□□-6FV62			
	87		91	
Rated supply voltage armature ¹⁾	V	3-ph. AC 460 (+15 % / -20 %)		
Rated input current armature ²⁾	A	705	995	
Rated supply voltage electronics supply	V	2-ph. AC 380 (-25%) to 460 (+15%); $I_n=1$ A or 1-ph. AC 190 (-25%) to 230 (+15%); $I_n=2$ A (-35% for 1 min)		
Rated supply voltage fan	V	1-ph. AC 230 (±10%) 50 Hz	60 Hz	1-ph. AC 230 (±10%) 50 Hz
Nominal fan current	A	0.55	0.55	2.6
Air flow rate	m ³ /h	570	570	1300
Fan noise level	dBA	73	76	82
Rated supply voltage field ¹⁾	V	2-ph. AC 460 (+15 % / -20 %)		
Rated frequency	Hz	45 to 65 ⁹⁾		
Rated DC voltage ¹⁾	V	480		
Rated DC current	A	850		1200
Overload capability ⁵⁾		Max. 1.8 times rated DC current		
Rated output	kW	408	576	
Power loss at rated DC current (approx.)	W	2514	4620	
Rated DC voltage field ¹⁾	V	Max. 375		
Rated DC current field	A	30		
Operational ambient temperature	°C	0 to 40 at I_{rated} ³⁾ separately cooled		
Storage and transport temperature	°C	-25 to +70		
Installation altitude above sea level		≤ 1000 m at rated DC current ⁴⁾		
Dimensions (H x W x D)	mm	700 x 268 x 362	780 x 410 x 362	
See dimension drawing on Page		8/12	8/8	
Weight (approx.)	kg	47	85	

3

1) The armature/field supply voltage can be less than the rated supply voltage armature/field (set with Parameter P078; for converters with 400 V rated voltage, input voltages of up to 85 V are permissible). The output voltage is reduced accordingly. The specified output DC voltage can be guaranteed up to undervoltages 5 % below the supply voltage (rated supply voltage armature/field).

2) Values apply to output rated DC current.

3) Load factor K1 (DC current) as a function of the coolant temperature (see P077 Operating Instructions, Section 11).
K1 > 1 only permissible where $K1 * K2 \leq 1st.$
overall reduction factor $K = K1 * K2$
(for K2 see Footnote 4).

Ambient or coolant temperature	Load factor K1	
	In devices with self-cooling	In devices with enhanced cooling
≤ +30 °C	1.18	1.10
+35 °C	1.12	1.05
+40 °C	1.06	1.00
+45 °C	1.00	0.95
+50 °C	0.94	0.90 ^{a)}
+55 °C	0.88	
+60 °C	0.82 ^{b)}	

a) In spite of derating, converters of ≥ 400 A with enhanced cooling may be operated at an ambient or coolant temperature of 50 °C only if the rated supply voltage of the converter fan is safely within the limited tolerance range of 400 V +10% -15%.

b) Not permissible when T400 or OP1S are used.

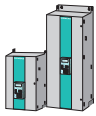

SIMOREG 6RA70 DC MASTER

Technical Data

Converters for four-quadrant operation

3-ph. AC 575 V, 60 A to 600 A, 4Q

Type	6RA70□□-6GV62				
	25	31	75	81	85
Rated supply voltage armature ¹⁾	V 3-ph. AC 575 (+10% / -20%)				
Rated input current armature ²⁾	A 50	104	175	332	498
Rated supply voltage electronics supply	V 2-ph. AC 380 (-25%) to 460 (+15%); $I_n=1$ A or 1-ph. AC 190 (-25%) to 230 (+15%); $I_n=2$ A (-35% for 1 min)				
Rated supply voltage fan	V		24 V DC internal	3-ph. AC 400 (±15%) 50 Hz 3-ph. AC 460 (±10%) 60 Hz	
Nominal fan current	A			0.3 ⁷⁾	
Air flow rate	m ³ /h		100	570	
Fan noise level	dBA		40	73	
Rated supply voltage field ¹⁾	V 2-ph. AC 460 (+15 % / -20 %)				
Rated frequency	Hz 45 to 65 ⁹⁾				
Rated DC voltage ¹⁾	V 600				
Rated DC current	A 60	125	210	400	600
Overload capability ⁵⁾	Max. 1.8 times rated DC current				
Rated output	kW 36	75	126	240	360
Power loss at rated DC current (approx.)	W 265	455	730	1550	1955
Rated DC voltage field ¹⁾	V Max. 375				
Rated DC current field	A 10		15	25	
Operational ambient temperature	°C 0 to 45 at I_{rated} ³⁾ self-cooled		0 to 40 at I_{rated} ³⁾ separately cooled		
Storage and transport temperature	°C -25 to +70				
Installation altitude above sea level	≤ 1000 m at rated DC current ⁴⁾				
Dimensions (H x W x D)	mm 385 x 265 x 283			625 x 268 x 318	
See dimension drawing on Page	8/6			8/7	
Weight (approx.)	kg 14	16		30	

3

- 4) Load values K2 as a function of the installation altitude (see P077 Operating Instructions, Section 11);
Overall reduction factor $K = K1 * K2$
(for K1 see Footnote 3).

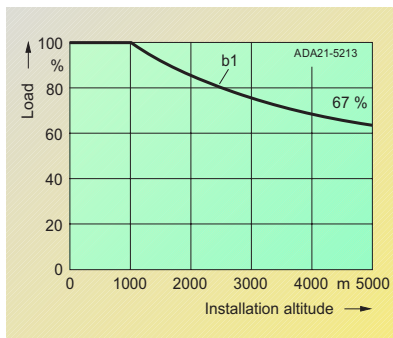

Curve b1: Reduction factor of load values (DC current) at installation altitudes above 1000 m.

Installation altitude m	1000	2000	3000	4000	5000
Reduction factor K2	1.0	0.835	0.74	0.71	0.67

The supply voltages for all electric circuits are possible for site altitudes up to 5000 m with basic insulation, with the exception of converters for 830 V rated supply voltage:
up to 4000 m 830 V
up to 4500 m 795 V
up to 5000 m 727 V

- 5) See Section 5.

7) For UL systems, a Siemens motor protection circuit-breaker Type 3RV1011-0DA1 or 3RV1011-0EA1, adjusted to 0.3 A for the fan motor Type R2D220-AB02-19 must be installed in 6RA7081, 6RA7085 and 6RA7087 converters with a rated voltage of 400 V or 575 V.

- 9) Operation in the extended frequency range of 23 Hz to 110 Hz is possible on request.

SIMOREG 6RA70 DC MASTER

Technical Data

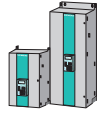

Converters for four-quadrant operation

3-ph. AC 575 V, 850 A to 2000 A, 4Q

Type	6RA70□□-6GV62			6RA70□□-4GV62	
	87	90	93	95	
Rated supply voltage armature ¹⁾	V 3-ph. AC 575 (+10% / -20%)				
Rated input current armature ²⁾	A 705	912	1326	1658	
Rated supply voltage electronics supply	V 2-ph. AC 380 (-25%) to 460 (+15%); $I_n=1$ A or 1-ph. AC 190 (-25%) to 230 (+15%); $I_n=2$ A (-35% for 1 min)				
Rated supply voltage fan	V 3-ph. AC 400 (±15%) 50 Hz 3-ph. AC 460 (±10%) 60 Hz		3-ph. AC 400 (±10%) 50 Hz 3-ph. AC 460 (±10%) 60 Hz		3-ph. AC 400 (±10%) 50 Hz 3-ph. AC 460 (±10%) 60 Hz
Nominal fan current	A 0.3 ⁷⁾	1.0 ⁸⁾	1.25 ⁸⁾	1.0 ⁸⁾	1.25 ⁸⁾
Air flow rate	m ³ /h 570	1300	1300	2400	2400
Fan noise level	dBA 73	83	87	83	87
Rated supply voltage field ¹⁾	V 2-ph. AC 460 (+15% / -20%)				
Rated frequency	Hz 45 to 65 ⁹⁾				
Rated DC voltage ¹⁾	V 600				
Rated DC current	A 850	1100	1600	2000	
Overload capability ⁵⁾	Max. 1.8 times rated DC current				
Rated output	kW 510	660	960	1200	
Power loss at rated DC current (approx.)	W 2780	4515	5942	7349	
Rated DC voltage field ¹⁾	V Max. 375				
Rated DC current field	A 30			40	
Operational ambient temperature	°C 0 to 40 at I_{rated} ³⁾ separately cooled				
Storage and transport temperature	°C -25 to +70				
Installation altitude above sea level	≤ 1000 m at rated DC current ⁴⁾				
Dimensions (H x W x D)	mm 700 x 268 x 362	780 x 410 x 362	880 x 450 x 500		
See dimension drawing on Page	8/7	8/8			
Weight (approx.)	kg 45	85	145		

1) The armature/field supply voltage can be less than the rated supply voltage armature/field (set with Parameter P078; for converters with 400 V rated voltage, input voltages of up to 85 V are permissible). The output voltage is reduced accordingly. The specified output DC voltage can be guaranteed up to undervoltages 5 % below the supply voltage (rated supply voltage armature/field).

2) Values apply to output rated DC current.

3) Load factor K1 (DC current) as a function of the coolant temperature (see P077 Operating Instructions, Section 11).
K1 > 1 only permissible where $K1 * K2 \leq 1st.$
overall reduction factor $K = K1 * K2$
(for K2 see Footnote 4).

Ambient or coolant temperature	Load factor K1	
	In devices with self-cooling	In devices with enhanced cooling
≤ +30 °C	1.18	1.10
+35 °C	1.12	1.05
+40 °C	1.06	1.00
+45 °C	1.00	0.95
+50 °C	0.94	0.90 ^{a)}
+55 °C	0.88	
+60 °C	0.82 ^{b)}	

a) In spite of derating, converters of ≥ 400 A with enhanced cooling may be operated at an ambient or coolant temperature of 50 °C only if the rated supply voltage of the converter fan is safely within the limited tolerance range of 400 V +10% -15%.

b) Not permissible when T400 or OP1S are used.

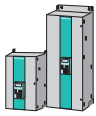

SIMOREG 6RA70 DC MASTER

Technical Data

Converters for four-quadrant operation

3-ph. AC 690 V, 760 A to 2000 A, 4Q

Type	6RA70□□-6KV62			6RA70□□-4KV62	
	86	90	93	95	
Rated supply voltage armature ¹⁾	V 3-ph. AC 690 (+10% / -20%)				
Rated input current armature ²⁾	A 630	829	1244	1658	
Rated supply voltage electronics supply	V 2-ph. AC 380 (-25%) to 460 (+15%); $I_n=1$ A or 1-ph. AC 190 (-25%) to 230 (+15%); $I_n=2$ A (-35% for 1 min)				
Rated supply voltage fan	V 3-ph. AC 400 (±15%) 50 Hz 3-ph. AC 460 (±10%) 60 Hz		3-ph. AC 400 (±10%) 50 Hz 3-ph. AC 460 (±10%) 60 Hz		3-ph. AC 400 (±10%) 50 Hz 3-ph. AC 460 (±10%) 60 Hz
Nominal fan current	A 0.3 ⁷⁾	1.0 ⁸⁾	1.25 ⁸⁾	1.0 ⁸⁾	1.25 ⁸⁾
Air flow rate	m ³ /h 570	1300	1300	2400	2400
Fan noise level	dBA 73	83	87	83	87
Rated supply voltage field ¹⁾	V 2-ph. AC 460 (+15% / -20%)				
Rated frequency	Hz 45 to 65 ⁹⁾				
Rated DC voltage ¹⁾	V 725				
Rated DC current	A 760	1000	1500	2000	
Overload capability ⁵⁾	Max. 1.8 times rated DC current				
Rated output	kW 551	725	1088	1450	
Power loss at rated DC current (approx.)	W 2850	4605	6706	8190	
Rated DC voltage field ¹⁾	V Max. 375				
Rated DC current field	A 30			40	
Operational ambient temperature	°C 0 to 40 at I_{rated} ³⁾ separately cooled				
Storage and transport temperature	°C -25 to +70				
Installation altitude above sea level	≤ 1000 m at rated DC current ⁴⁾				
Dimensions (H x W x D)	mm 700 x 268 x 362	780 x 410 x 362	880 x 450 x 500		
See dimension drawing on Page	8/7	8/8			
Weight (approx.)	kg 45	85	145		

3

- 4) Load values K2 as a function of the installation altitude (see P077 Operating Instructions, Section 11);
Overall reduction factor $K = K1 * K2$
(for K1 see Footnote 3).

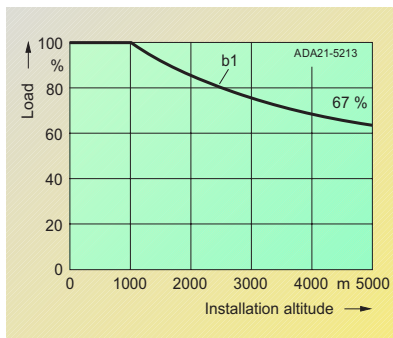

Curve b1: Reduction factor of load values (DC current) at installation altitudes above 1000 m.

Installation altitude m	1000	2000	3000	4000	5000
Reduction factor K2	1.0	0.835	0.74	0.71	0.67

The supply voltages for all electric circuits are possible for site altitudes up to 5000 m with basic insulation, with the exception of converters for 830 V rated supply voltage:
up to 4000 m 830 V
up to 4500 m 795 V
up to 5000 m 727 V

- 5) See Section 5.

7) For UL systems, a Siemens motor protection circuit-breaker Type 3RV1011-0DA1 or 3RV1011-0EA1, adjusted to 0.3 A for the fan motor Type R2D220-AB02-19 must be installed in 6RA7081, 6RA7085 and 6RA7087 converters with a rated voltage of 400 V or 575 V.

8) For UL systems, a Siemens motor protection circuit-breaker Type 3RV1011-0KA1 or 3RV1011-1AA1, adjusted to 1.25 A for the fan motor Type RH28M-2DK.3F.1R must be installed in 6RA7090, 6RA7091, 6RA7093 and 6RA7095 converters with a rated voltage of 400 V or 575 V.

9) Operation in the extended frequency range of 23 Hz to 110 Hz is possible on request.

SIMOREG 6RA70 DC MASTER

Technical Data

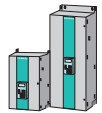

Converters for four-quadrant operation

3-ph. AC 830 V, 950 A to 1900 A, 4Q

Type	6RA70□□-6LV62		6RA70□□-4LV62	
	88	93	93	95
Rated supply voltage armature ¹⁾	V	3-ph. AC 830 (+10% / 20%)		
Rated input current armature ²⁾	A	788	1244	1575
Rated supply voltage electronics supply	V	2-ph. AC 380 (-25% to 460 (+15%); $I_n=1$ A or 1-ph. AC 190 (-25% to 230 (+15%); $I_n=2$ A (-35% for 1 min)		
Rated supply voltage fan	V	3-ph. AC 400 (±10%) 50 Hz 3-ph. AC 460 (±10%) 60 Hz		3-ph. AC 400 (±10%) 50 Hz 3-ph. AC 460 (±10%) 60 Hz
		50 Hz	60 Hz	50 Hz 60 Hz
Nominal fan current	A	1.0 ⁸⁾	1.25 ⁸⁾	1.0 ⁸⁾ 1.25 ⁸⁾
Air flow rate	m ³ /h	1300	1300	2400 2400
Fan noise level	dBA	83	87	83 87
Rated supply voltage field ¹⁾	V	2-ph. AC 460 (+15% / -20%)		
Rated frequency	Hz	45 to 65 ⁹⁾		
Rated DC voltage ¹⁾	V	875		
Rated DC current	A	950	1500	1900
Overload capability ⁵⁾		Max. 1.8 times rated DC current		
Rated output	kW	831	1313	1663
Power loss at rated DC current (approx.)	W	4870	7153	8700
Rated DC voltage field ¹⁾	V	Max. 375		
Rated DC current field	A	30	40	
Operational ambient temperature	°C	0 to 40 at I_{rated} ³⁾ separately cooled		
Storage and transport temperature	°C	-25 to +70		
Installation altitude above sea level		≤ 1000 m at rated DC current ⁴⁾		
Dimensions (H x W x D)	mm	780 x 410 x 362	880 x 450 x 500	
See dimension drawing on Page		8/8		
Weight (approx.)	kg	85	145	

3

1) The armature/field supply voltage can be less than the rated supply voltage armature/field (set with Parameter P078; for converters with 400 V rated voltage, input voltages of up to 85 V are permissible). The output voltage is reduced accordingly. The specified output DC voltage can be guaranteed up to undervoltages 5 % below the supply voltage (rated supply voltage armature/field).

2) Values apply to output rated DC current.

3) Load factor K1 (DC current) as a function of the coolant temperature (see P077 Operating Instructions, Section 11).
K1 > 1 only permissible where $K1 * K2 \leq 1st.$
overall reduction factor $K = K1 * K2$
(for K2 see Footnote 4).

Ambient or coolant temperature	Load factor K1	
	In devices with self-cooling	In devices with enhanced cooling
≤ +30 °C	1.18	1.10
+35 °C	1.12	1.05
+40 °C	1.06	1.00
+45 °C	1.00	0.95
+50 °C	0.94	0.90 ^{a)}
+55 °C	0.88	
+60 °C	0.82 ^{b)}	

a) In spite of derating, converters of ≥ 400 A with enhanced cooling may be operated at an ambient or coolant temperature of 50 °C only if the rated supply voltage of the converter fan is safely within the limited tolerance range of 400 V +10% -15%.

b) Not permissible when T400 or OP1S are used.

4) Load values K2 as a function of the installation altitude (see P077 Operating Instructions, Section 11). Overall reduction factor $K = K1 * K2$ (for K1 see Footnote 3).

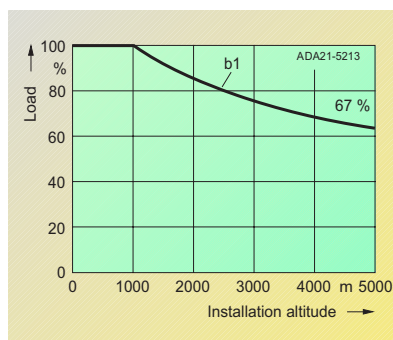

Curve b1: Reduction factor of load values (DC current) at installation altitudes above 1000 m.

Installation altitude m	1000	2000	3000	4000	5000
Reduction factor K2	1.0	0.835	0.74	0.71	0.67

The supply voltages for all electric circuits are possible for site altitudes up to 5000 m with basic insulation, with the exception of converters for 830 V rated supply voltage:
up to 4000 m 830 V
up to 4500 m 795 V
up to 5000 m 727 V

5) See Section 5.

8) For UL systems, a Siemens motor protection circuit-breaker Type 3RV1011-0KA1 or 3RV1011-1AA1, adjusted to 1.25 A for the fan motor Type RH28M-2DK.3F.1R must be installed in 6RA7090, 6RA7091, 6RA7093 and 6RA7095 converters with a rated voltage of 400 V or 575 V.

9) Operation in the extended frequency range of 23 Hz to 110 Hz is possible on request.

SIMOREG 6RA70 DC MASTER Options

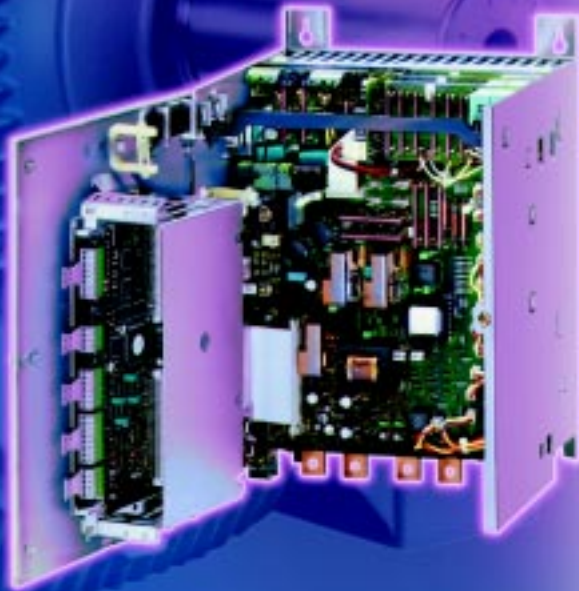

4/2
4/3

Options in the basic unit

Technology software in the basic unit
Terminal expansion board CUD2

4/6
4/7
4/8
4/8

Integration of the electronics options

Overview
Installation of the electronics options
Backplane bus adapter LBA
Adapter board ADB

4/9
4/11
4/13
4/15

Terminal expansions

Optional board SBP for pulse encoder
Terminal expansion board EB1
Terminal expansion board EB2
Interface boards SCI1 and SCI2

4/19
4/24
4/26

Technology boards

Technology board T400
Technology board T100
T300 technology board

4/27
4/28
4/30
4/32
4/34
4/35

Communication

Overview
SIMOLINK communication board SLB
PROFIBUS-DP communication board CBP2
CAN communication board CBC
Communication board CBD DeviceNet
SCB1 interface board

4/36
4/38
4/39

Operating and monitoring

OP1S operator panel
DriveMonitor
Drive ES engineering package

4/42

Performance options

SIMOREG 6RL70 rectifier module

SIMOREG 6RA70 DC MASTER

Options

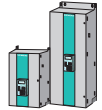

Options in the basic unit

“Technology software” in the basic unit

The software option “Technology software” in the basic unit is released for use by means of a PIN number.

If the converter is ordered with the appropriate short code, it will be supplied with the software option enabled. The PIN number is supplied with the unit.

If this option is ordered subsequently, the PIN number will be sent to the customer who must enable the option as described in the operating instructions.

Software modules

The following software modules are available:

- Fixed values
- 32 fault message trigger signals
- 8 warning message trigger signals
- 3 connector/binector converters
- 3 binector/connector converters
- 15 adders/subtractors
- 4 sign inverters
- 2 switchable sign inverters
- 12 multipliers
- 6 dividers
- 3 high-resolution multipliers/dividers
- 4 absolute-value generators with filter
- 3 limiters
- 3 limit-value monitors with filter
- 7 limit-value monitors without filter
- 4 mean-value generators
- 4 maximum selections
- 4 minimum selections
- 2 tracking/storage elements
- 2 connector memories
- 10 connector selector switches
- 2 limit-value monitors (for dual connectors)
- 2 connector-type converters
- 2 adders/subtractors (for dual connectors)
- 3 integrators
- 3 DT1 elements
- 10 derivative action/ delay elements
- 9 characteristic blocks
- 3 dead zones
- 1 setpoint shift
- 1 simple ramp-function generator
- 1 technology controller
- 10 PI controllers
- 1 velocity/speed/ calculator
- 1 speed/velocity calculator
- 1 calculation of variable torque
- 3 multiplexers
- 1 software counter, 16-bit
- 2 decoders/demultiplexers binary, 1 from 8
- 28 AND elements
- 20 OR elements
- 4 EXCLUSIVE OR elements
- 16 inverters
- 12 NAND elements
- 14 RS flipflops
- 4 D flipflops
- 6 timers (0,000 to 60,000s)
- 4 timers (0,00 to 600,00s)
- 5 binary signal selector switches

Technology controller

The technology controller can be used for higher-level closed-loop controls, such as, tension, position or pressure controllers. The output can be wired as required and can act, for example, as a main setpoint, additional setpoint or current limit.

The technology controller is a PID controller with separate settings for the closed-loop control characteristics. A droop setting is also available.

Connector numbers can be entered freely to select the source for setpoint and actual value. A filter (PT1 element) can be parameterized at the setpoint and actual value inputs.

The technology controller output can be limited by mutually independent, positive and negative values, which can be parameterized or input via freely selectable connectors. The output signal can be weighted multiplicatively (parameterized or via connector signal) after the limiting stage.

4

Selection and ordering data

Description	Code	Order No.:
Technology software in the basic unit	S00	6RX1700-0AS00

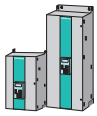

Terminal expansion board CUD2

The terminal expansion board CUD2 is mounted on the basic electronics assembly CUD1 and does not require any additional built-in components. This board provides a range of additional inputs and outputs.

Apart from these additional inputs and outputs, terminal expansion board CUD2 provides an additional RS 485 serial interface as well as a parallel interface for connecting up to 5 power supply modules in parallel.

Terminals on terminal expansion board CUD2

- 4 binary selectable inputs via optocouplers, can also be used as interface to motor
- 4 binary selectable inputs to ground
- 2 analog inputs to ground, ± 10 bit resolution
- 1 analog input for evaluation of motor temperature via PTC or KTY84
- 2 P24 binary inputs to ground, open emitter, 100 mA load rating
- 2 analog outputs to ground, ± 10 V, 2 mA load rating, ± 11 bit resolution
- 1 serial interface, two-wire and four-wire RS 485, max. 187.5 kbd
- 1 parallel interface (2 connectors) for parallel connection of SIMOREG
- P24 power supply for driving binary inputs
- 8 terminals for converter ground

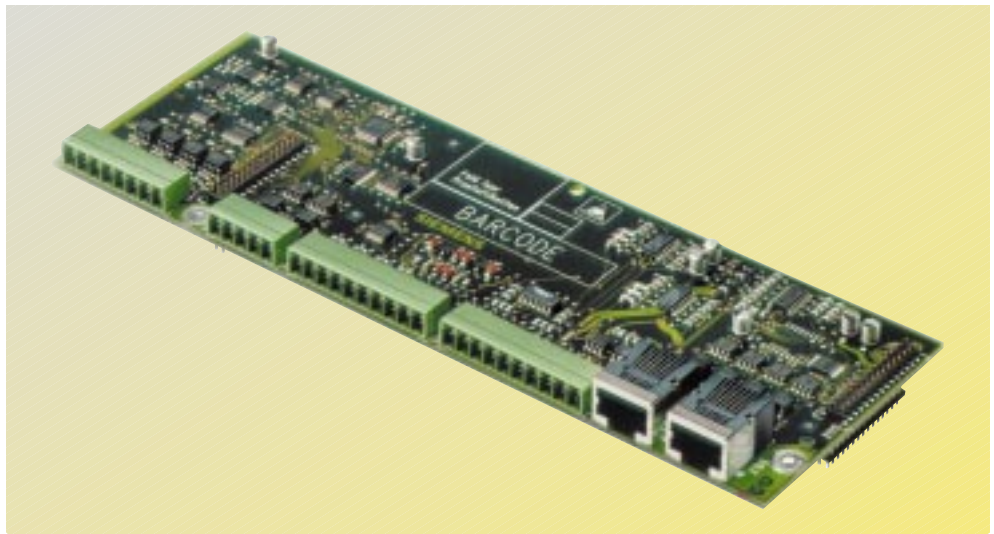

Fig. 4/1
Terminal expansion board CUD2

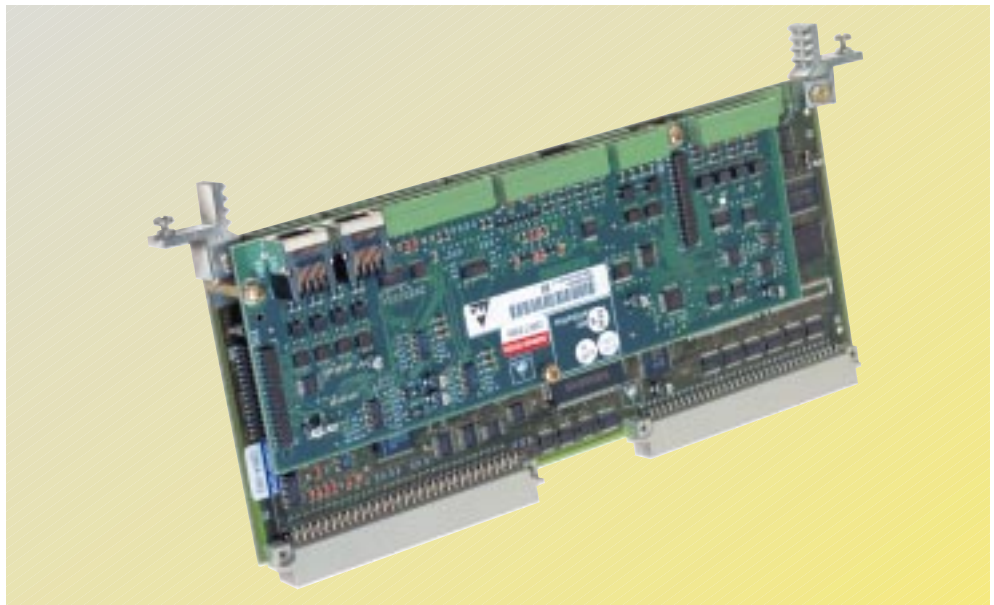

Fig. 4/2
Terminal expansion board CUD2 plugged into the basic board CUD1

Selection and ordering data

Description	Code	Order No.:
CUD2 Terminal expansion board	K00	6RX1700-0AK00

SIMOREG 6RA70 DC MASTER

Options

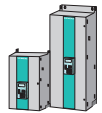

Options in the basic unit

Terminal expansion board CUD2 · Terminal assignments

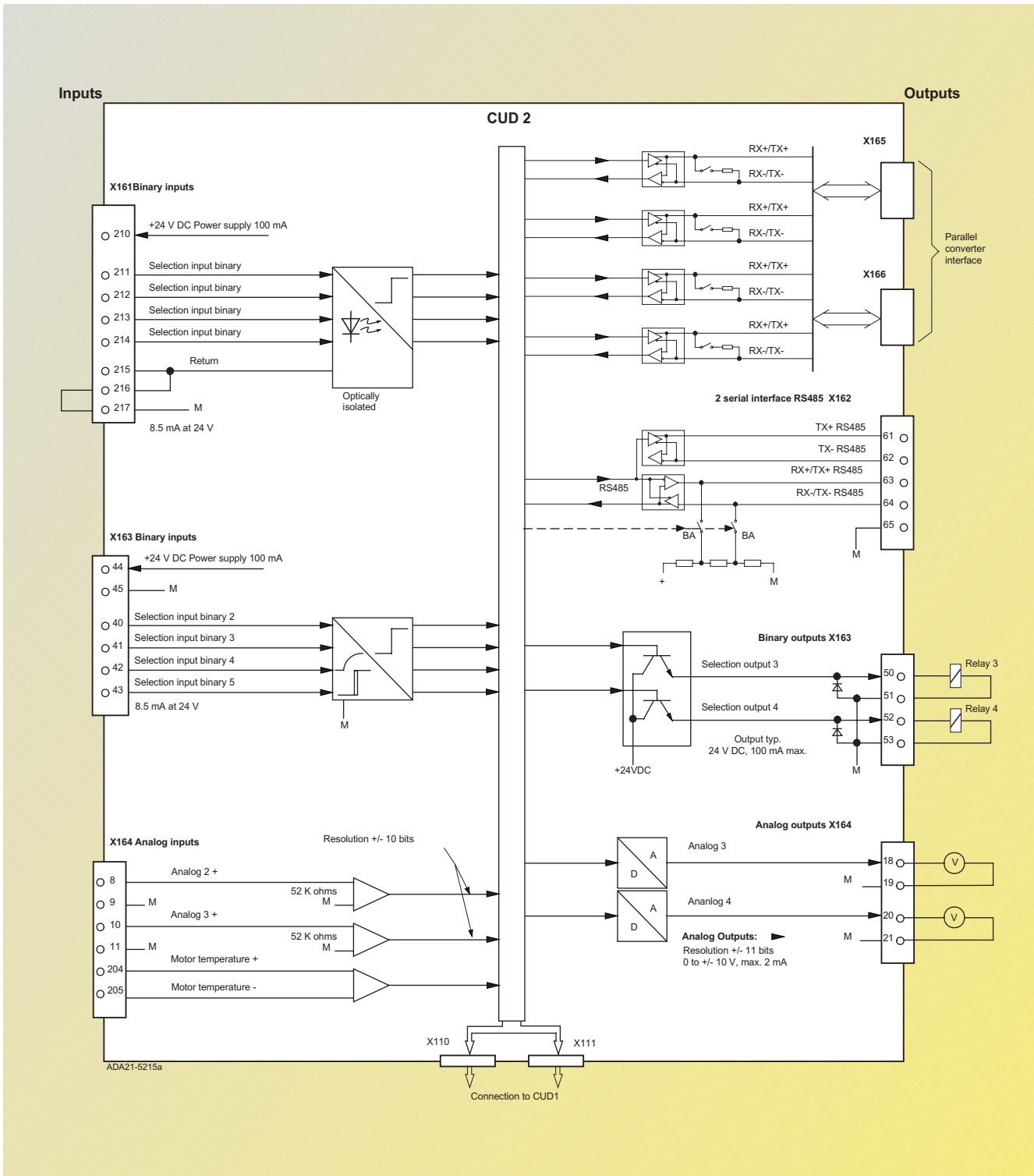
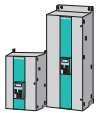

Fig. 4/3
Block diagram of the terminal expansion board CUD2



SIMOREG 6RA70 DC MASTER

Options

Options in the basic unit

Terminal expansion board CUD2 - Terminal assignments

Type	Terminal design	Function	Terminal	Connection values/comments	
Motors interface	Plug-in terminal (screw terminal) Max. cross-section 1.5 mm ²	Motor temperature: – Positive terminal	X164/204	Sensor according to P146 Index 2	
		– Negative terminal	X164/205		Sensor according to P146 Index 2
		Supply for binary inputs	X164/210	24 V DC, max. load	
		Binary input	X164/211	Evaluation of motor data	
			X164/212		
			X164/213		
			X164/214		
		Ground M_GT: – Binary inputs	X164/215	Can be isolated from internal ground Remove jumper between terminals 216 and 217.	
– Binary inputs	X164/216				
M	X164/217	Remove jumper between terminals 216 and 217.			
Analog inputs	Plug-in terminal (screw terminal) Max. cross-section 1.5 mm ²	Selectable input analog 2	X164/8	±10 V, 52 kΩ	
		Analog ground	X164/9		Resolution: ±10 bit
		Selectable input analog 3	X164/10	Signs can be reversed and signals switched through by means of binary input functions.	
		Analog ground	X164/11		
Analog outputs	Plug-in terminal (screw terminal) Max. cross-section 1.5 mm ²	Selectable output analog 3	X164/18	0 to ±10 V, max. 2 mA short-circuit-proof, resolution ±11 bits	
		Analog ground	X164/19		
		Selectable output analog 4	X164/20		
		Analog ground M	X164/21		
Binary control inputs	Plug-in terminal (screw terminal) Max. cross-section 1.5 mm ²	Supply	X163/44	24 V DC, max. load 100 mA, internal supply referred to internal ground	
		Digital ground M	X163/45	1)	
		Selectable input: – Binary 2	X163/40	1)	
		– Binary 3	X163/41		
		– Binary 4	X163/42		
		– Binary 5	X163/43		
Binary control outputs	Plug-in terminal (screw terminal) Max. cross-section 1.5 mm ²	Ground M: – Binary selectable outputs	X163/51	2)	
		– Binary selectable outputs	X163/53		
		Selectable output: – Binary 3	X163/50		Short-circuit-proof 100 mA
		– Binary 4	X163/52		
Serial interface 3 RS 485³⁾ 4)	Plug-in terminal (screw terminal) Max. cross-section 1.5 mm ²	TX+	X172/61	RS 485, 4-wire send cable, positive differential input	
		TX–	X172/61	RS 485, 4-wire send cable, negative differential input	
		RX+/TX+	X172/63	RS 485, 4-wire receive cable, positive differential input, 2-wire send/receive cable, positive differential input	
		RX–/TX–	X172/64	RS 485, 4-wire receive cable, negative differential input, 2-wire send/receive cable, negative differential input	
		M X172/65		Ground	

1) H signal: +13 to +33 V*
L signal: –33 to +3 V
or unconnected terminals*

* For binary control inputs
8.5 mA at 24 V

2) H signal: +13 to +30 V
L signal: 0 to +2 V

3) Cable length:
– For baud rate of 187.5 kbd: 600 m
– For transmission rate of
≤ 93.75 kbd: 1200 m

4) Please observe DIN 19 245 Part 1. In particular, the potential difference between the data reference potentials M of all interfaces must not exceed - 7 V / +12 V. If this cannot be guaranteed, then equipotential bonding must be provided.

SIMOREG 6RA70 DC MASTER

Options

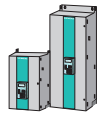

Integration of the electronics options

Overview

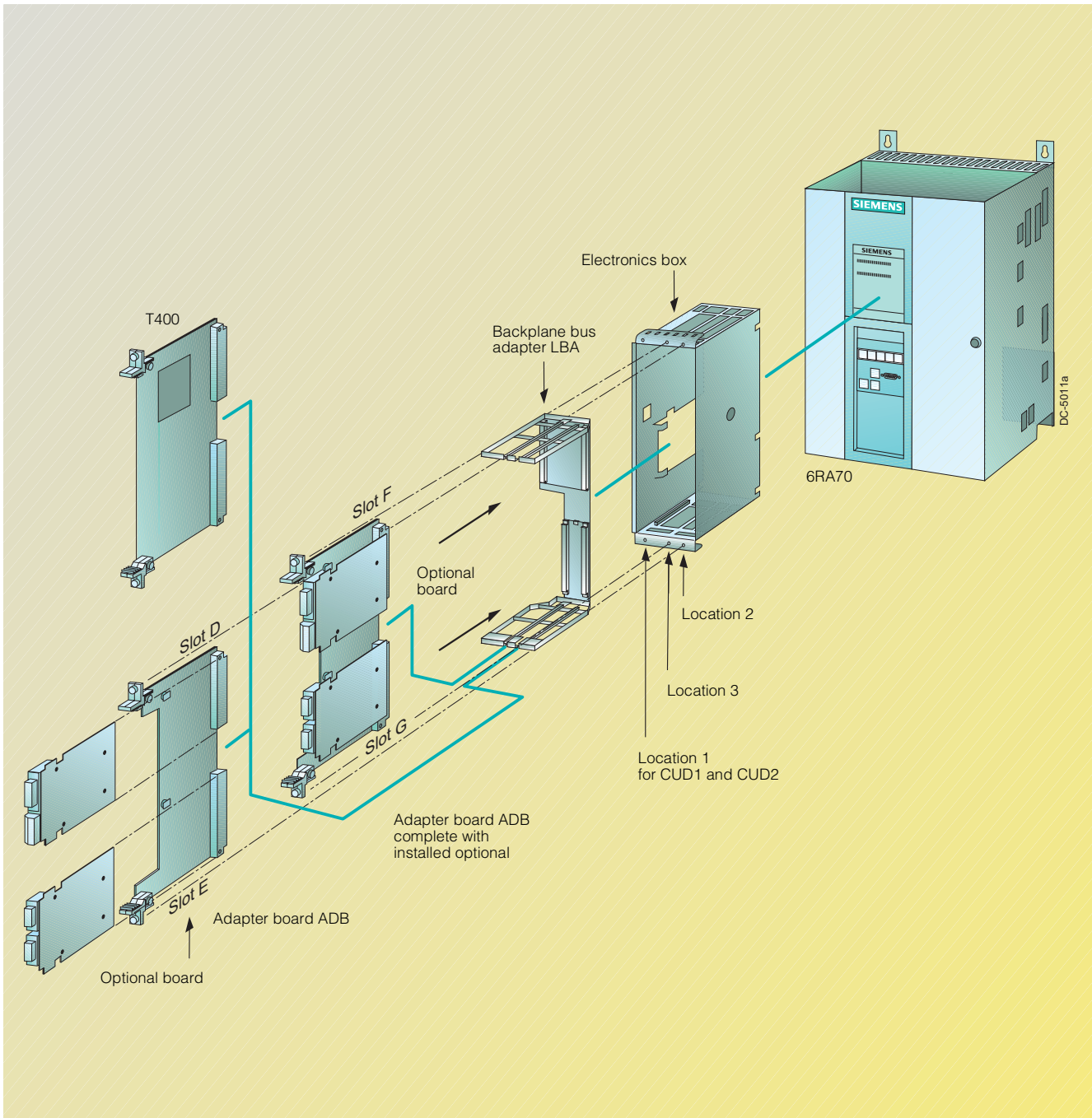
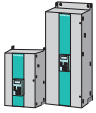

Fig. 4/4
Integration/fitting of the optional boards

In the electronics box of the SIMOREG 6RA70 converter, up to four slots are available for fitting optional boards. The slots are identified by characters D to G.

If slots D to G are required, the LBA (**L**ocal **B**us **A**dapter) must be installed first.

One adapter board is required for slot D and slot E and one for slots F and G when half-size optional boards are used.



Installation of the electronics options

The optional boards are installed in the slots of the electronics box. The LBA (**L**ocal **B**us **A**dapter, backplane wiring) must be installed before additional optional boards can be fitted. The designations of the mounting locations and the slots are shown in the adjacent Figure.

Optional boards can be inserted into any slots; the only rule is that location 2 must be occupied before location 3.

Note

- A technology board must always be inserted in location 2 of the electronics box.
- If a technology board is used in conjunction with a communication board, the communication board must be installed in slot G. In this configuration, the communication data is exchanged directly between the communication board and technology board T400.
- Boards EB1, EB2, SLB and SBP cannot be used in conjunction with a technology board.
- Data from large-format boards are always output from slot E or slot G. The software version of a technology board is indicated, for example, in r060.003.
- In addition to the Local Bus Adapter, an adapter board (ADB) is required for the mini boards (CBP2, SLB, EB1 etc.) because the mini boards have to be inserted in the adapter board before they can be installed in the electronics box due to their extremely small size.
- It is not possible to install two optional boards of the same type in a converter (e.g. 2 x EB1).

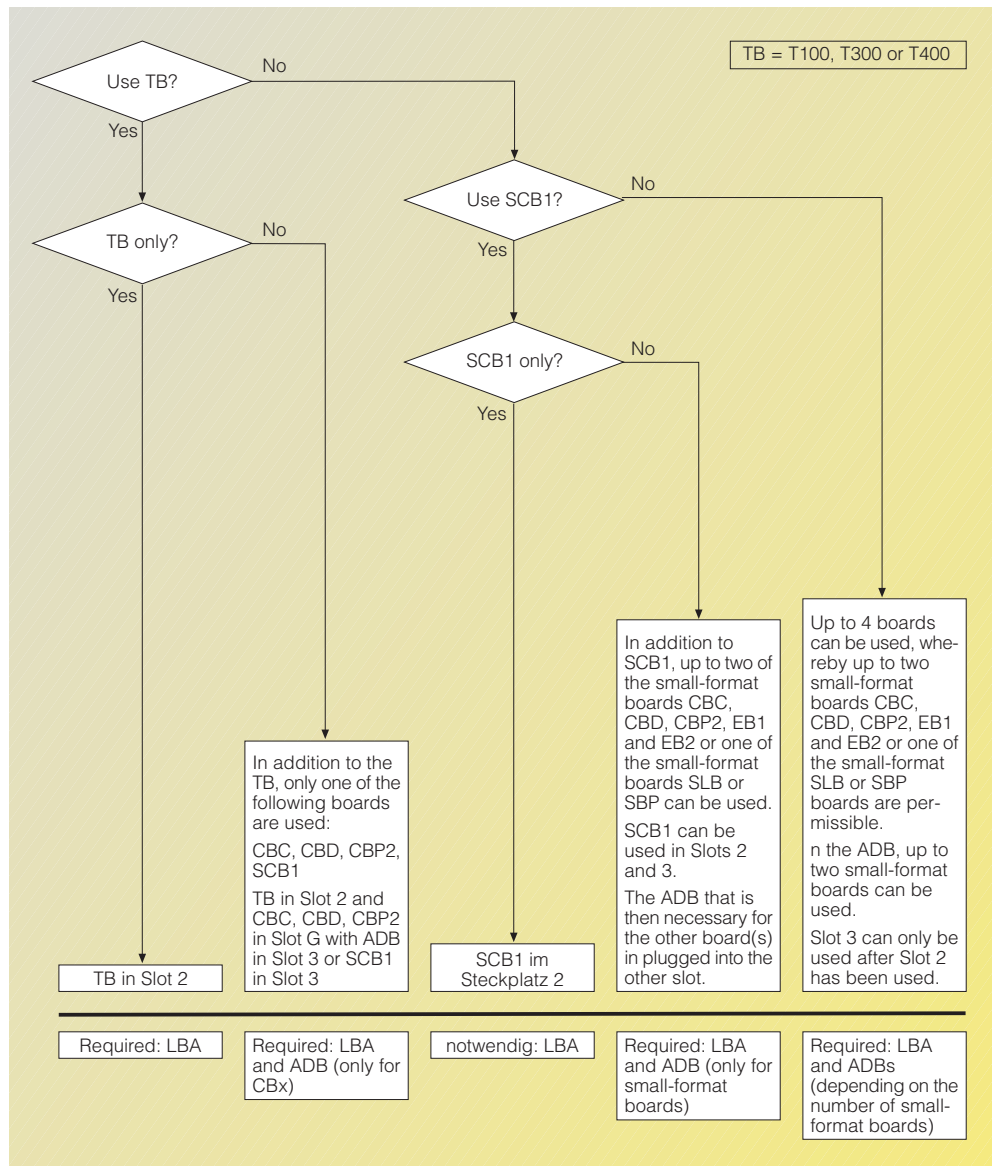

Fig. 4/6 Possible locations and slots for supplementary boards as well as their possible combinations

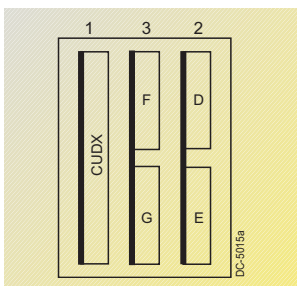

Fig. 4/5 Position of mounting locations 1 to 3 and slots D to G in the electronics

Installation possibilities in the electronics box

Board	LBA required	ADB required	Location 1		Location 2		Location 3	
			D	E	F	G		
CUD1	No	No	Yes	No	No	No	No	
CUD2	No	No	Yes	No	No	No	No	
CBP2	Yes	Yes	No	Yes	Yes	Yes	Yes	
CBC	Yes	Yes	No	Yes	Yes	Yes	Yes	
CBD	Yes	Yes	No	Yes	Yes	Yes	Yes	
SLB	Yes	Yes	No	Yes	Yes	Yes	Yes	
SBP	Yes	Yes	No	Yes	Yes	Yes	Yes	
SCB1	Yes	No	No	Yes			Yes	
T100	Yes	No	No	Yes			No	
T300	Yes	No	No	Yes			No	
T400	Yes	No	No	Yes			No	
EB1	Yes	Yes	No	Yes	Yes	Yes	Yes	
EB2	Yes	Yes	No	Yes	Yes	Yes	Yes	

SIMOREG 6RA70 DC MASTER

Options

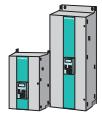

Integration of the electronics options

Backplane bus adapter LBA

The electronics box can be equipped with the backplane bus adapter LBA (Local Bus Adapter) in order to utilize locations 2 and 3. Two supplementary boards or the optional boards plugged into the adapter boards can be combined with the CUD1 in the electronics box. The CUD1 must be moved if the backplane bus adapter is used.

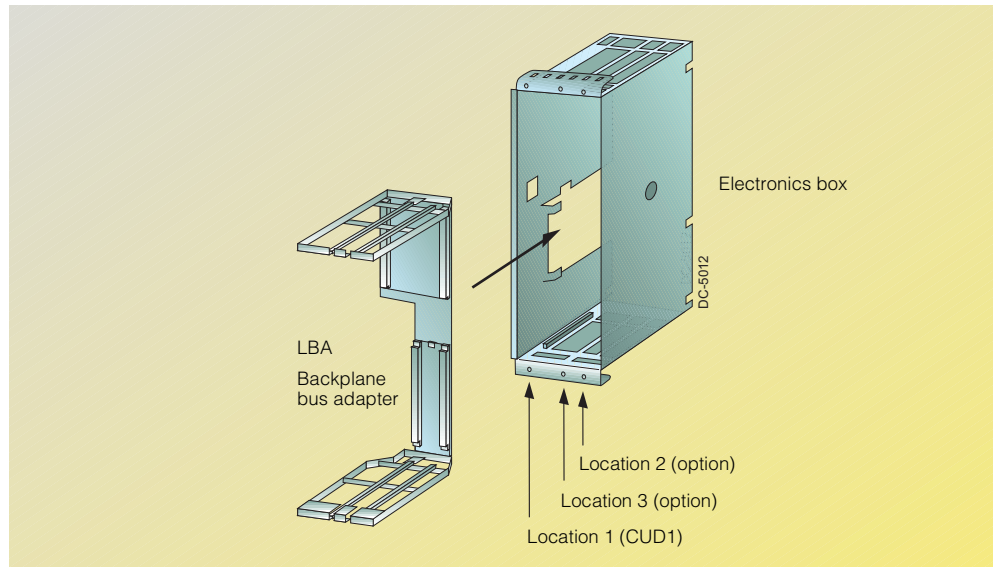

Fig. 4/7
Backplane bus adapter

Selection and ordering data

Description	Order No.:
LBA Backplane bus adapter	6SE7090-0XX84-4HA0

Adapter board ADB

The ADB (Adapter Board) is used to install supplementary boards, such as the CBP or SLB in locations 2 and 3 of the electronics box. Two supplementary boards can be installed on the adapter board. The backplane bus adapter is required if the adapter board is used.

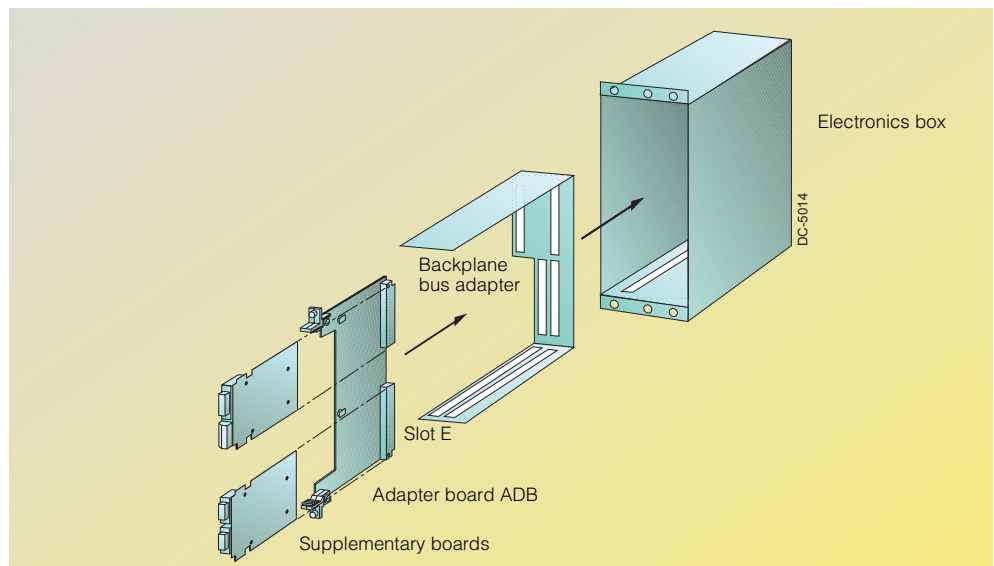
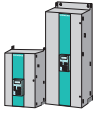

Fig. 4/8
Adapter board ADB

Selection and ordering data

Description	Order No.:
ADB Adapter board	6SE7090-0XX84-0KA0



Optional board SBP for pulse encoder

The optional board SBP (**S**ensor **B**oard **P**ulse) allows a second pulse encoder to be connected to the converter.

Suitable pulse encoders

All commercially available pulse encoders can be connected to this optional board. Their pulses can be processed as either bipolar or unipolar TTL or HTL level signals.

Encoder signals up to a pulse frequency of 410 kHz are possible (4096 pulses per rev. at 6 000 rpm). Encoder monitoring can also be implemented through evaluation of the check track.

The supply voltage for the connected encoder can be set to 5 V or 15 V.

Temperature sensor

The temperature sensor connection on the board is not evaluated in the SIMOREG system.

Connections

Signal cables are connected to terminal strips X400 and X401.

Connectable cross-section: 2.5 mm² (AWG12)

Maximum connectable encoder cable length with shielding as specified ¹⁾:

- 100 m (TTL signals)
- 150 m with Tracks A and B (HTL signals)
- 300 m with Track A+/A- and B+/B- (HTL signals).

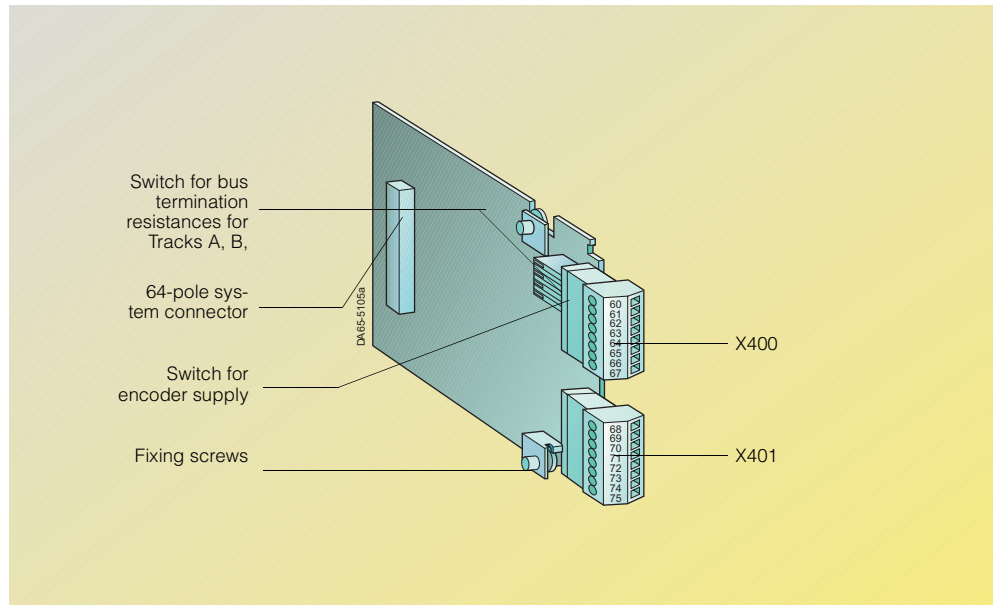

Fig. 4/9
Optional module SBP

Terminal assignments on terminal strip X400

Terminal	Designation	Meaning	Range
60	+V _{SS}	Power supply for pulse encoder	5/15 V I _{max} = 250 mA
61	-V _{SS}	Power supply ground	-
62	-Temp	Negative (-) terminal KTY84/PTC100	
63	+Temp	Positive (+) terminal KTY84/PTC100	
64	Coarse/fine ground	Ground	
65	Course pulse 1	Digital input course pulse 1	
66	Course pulse 2	Digital input course pulse 2	
67	Fine pulse 2	Digital input fine pulse 2	

Connectable cross-section: 0.14 mm² to 1.5 mm² (AWG 16)
Terminal 60 is on the top in the installed state.

Terminal assignments on terminal strip X401

Terminal	Designation	Meaning	Range
68	Track A+	Positive (+) terminal Track A	TTL/HTL/HTL unipolar
69	Track A-	Negative (-) terminal Track A	TTL/HTL/HTL unipolar
70	Track B+	Positive (+) terminal Track B	TTL/HTL/HTL unipolar
71	Track B-	Negative (-) terminal Track B	TTL/HTL/HTL unipolar
72	Zero pulse+	Positive (+) terminal Zero track	TTL/HTL/HTL unipolar
73	Zero pulse-	Negative (-) terminal Zero track	TTL/HTL/HTL unipolar
74	CTRL+	Positive (+) terminal Check track	TTL/HTL/HTL unipolar
75	CTRL- = M	Minus (-) terminal Check track = ground	TTL/HTL/HTL unipolar

Connectable cross-section: 0.14 mm² to 1.5 mm² (AWG 16)
Terminal 68 is on the top in the installed state.

SIMOREG 6RA70 DC MASTER

Options

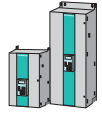

Terminal expansions

Optional board SBP for pulse encoder

Voltage range of encoder inputs

See adjacent tables.

Note

When unipolar signals are connected, one ground connection for all signals on the CTRL- terminal is sufficient. Due to the possibility of interference, it is recommended in the case of cables longer than 50 m that the four terminals A-, B-, zero pulse - and CTRL - are bridged and connected with the encoder ground.

	RS 422 (TTL)	HTL bipolar	HTL unipolar
Voltage range – Input	Max. 33 V; min. –33 V		
Voltage range + Input	Max. 33 V; min. –33 V		
Switching level Differential voltage – LOW	Min. –150 mV	Min. –2 V	Min. 4 V
Switching level Differential voltage – HIGH	Max. 150 mV	Max. 2 V	Max. 8 V

Voltage range of digital inputs

Note

The inputs are not floating. Course pulses are smoothed with 0.7 ms and fine pulses are smoothed with approximately 200 ns.

	Rated value	Min.	Max.
Voltage range LOW	0 V	–0.6 V	3 V
Voltage range HIGH	24 V	24 V	33 V
Input current LOW	≤ 2 mA		
Input current HIGH	10 mA	8 mA	12 mA

Selection and ordering data

Description	Order No.:
SBP Pulse encoder evaluation board	6SX7010-0FA00

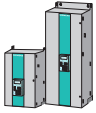

Terminal expansion board EB1

The number of digital and analog inputs and outputs can be expanded with terminal expansion board EB1 (Expansion-Board 1).

On terminal expansion board EB1, there are:

- 3 digital inputs
- 4 bidirectional digital inputs/ outputs
- 1 analog input with differential signal, for use as current or voltage input
- 2 analog inputs (single ended), that can also be used as digital inputs
- 2 analog outputs
- 1 input for the external 24 V supply for the digital outputs.

Terminal expansion board EB1 is installed in a slot in the electronics box. Boards LBA and ADB must be moved to allow installation.

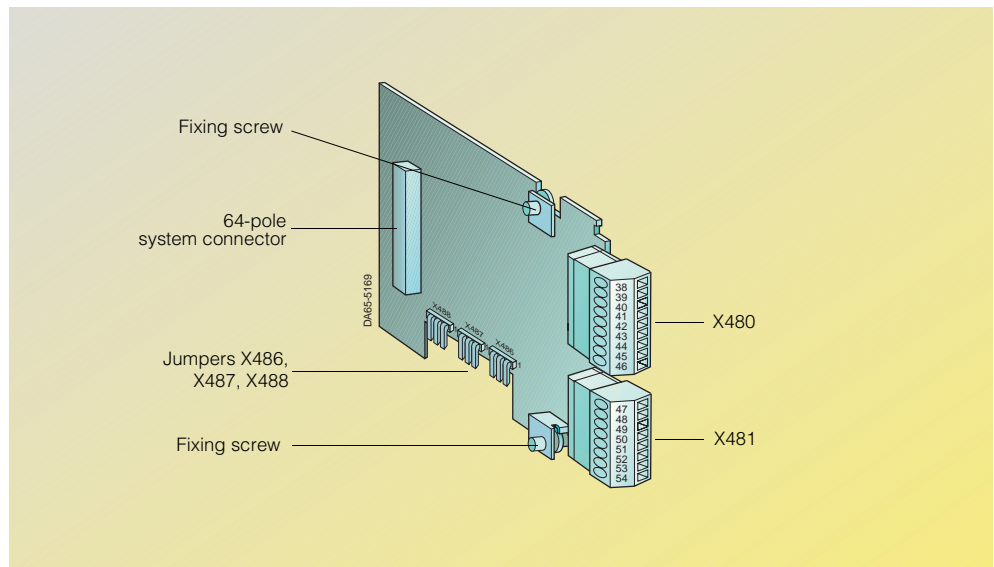

Fig. 4/10
Terminal expansion board EB1

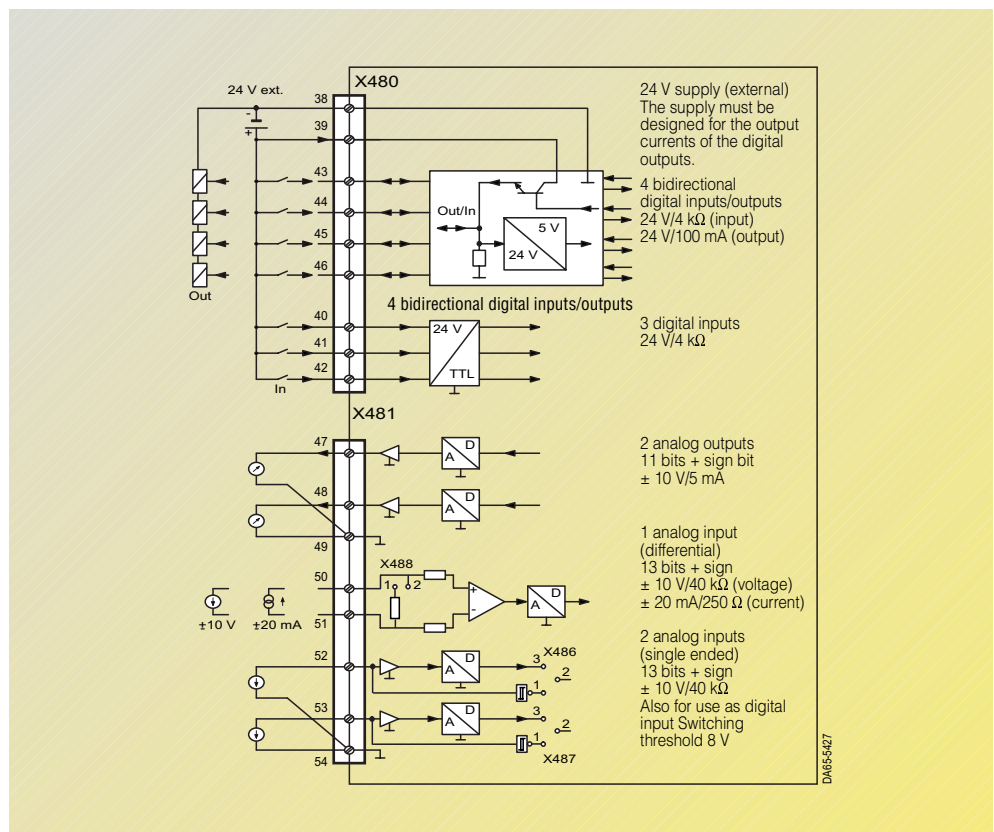
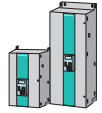

Fig. 4/11
Circuit diagram of the terminal expansion board EB1

SIMOREG 6RA70 DC MASTER

Options



Terminal expansions

Terminal expansion board EB1

Terminal X480

The terminal strip has the following terminals:

- 3 digital inputs
- 4 bidirectional digital inputs/outputs

The ground cables are protected with a reactor. In the installed state, Terminal 46 is on the top.

Note

The external 24 V supply is necessary and must be designed for the currents of the digital outputs.

Terminal	Designation	Meaning	Range
38	M	Digital ground	0 V
39	P24 ext.	Ext. 24 V supply	20 V to 33 V
40	DI1	Digital input 1	24 V, $R_i = 4 \text{ k}\Omega$
41	DI2	Digital input 2	24 V, $R_i = 4 \text{ k}\Omega$
42	DI3	Digital input 3	24 V, $R_i = 4 \text{ k}\Omega$
43	DIO1	Digital input/output 1	As input: 24 V, 4 k Ω
44	DIO2	Digital input/output 2	As output: Output voltage
45	DIO3	Digital input/output 3	Output voltage
46	DIO4	Digital input/output 4	P24 ext. 100 mA

Connectable cross-section: 0.14 - 1.5 mm² (AWG 16)

Terminal X481

The terminal strip has the following terminals:

- 1 analog input with differential signal, for use as current or voltage input
- 2 analog inputs (single ended), that can also be used as digital inputs
- 2 analog outputs

The ground cables are protected with a reactor. In the installed state, Terminal 47 is on the top.

Terminal	Designation	Meaning	Range
47	AO1	Analog output 1	$\pm 10 \text{ V}$, 5 mA
48	AO2	Analog output 2	$\pm 10 \text{ V}$, 5 mA
49	AOM	Analog output ground	0 V
50	AI1P	Analog input 1 +	Voltage: $\pm 10 \text{ V}$, 40 k Ω
51	AI1N	Analog input 1 -	Current: $\pm 20 \text{ mA}$, 250 Ω
52	AI2	Analog input 2	$\pm 10 \text{ V}$, 40 k Ω
53	AI3	Analog input 3	$\pm 10 \text{ V}$, 40 k Ω
54	AIM	Analog input ground	0 V

Connectable cross-section: 0.14 - 1.5 mm² (AWG 16)

Technical Data

Designation	Value
Digital inputs	DI1, DI2, DI3
• Voltage range LOW	0 V (-33 V to +5 V)
• Voltage range HIGH	+24 V (13 V to 33 V)
• Input resistance	4 k Ω
• Smoothing	250 μs
• Isolation	None
Bidirectional digital inputs/outputs	DIO1, DIO2, DIO3, DIO4
As input	
• Voltage range LOW	0 V (-33 V to +5 V)
• Voltage range HIGH	+24 V (13 V to 33 V)
• Input resistance	4 k Ω
As output	
• Voltage range LOW	< 2 V
• Voltage range HIGH	> P24 ext. -2.5 V
Analog input (differential input)	AI1P, AI1N
• Input range	
Voltage	$\pm 11 \text{ V}$
Current	$\pm 20 \text{ mA}$
• Input resistance	
Voltage	40 k Ω relative to frame
Current	250 Ω relative to frame
• Hardware smoothing	220 μs
• Resolution	13 bits + sign bit
Analog input (single ended)	AI2, AI3, AIM
• Input range	
Voltage	$\pm 11 \text{ V}$
Current	$\pm 20 \text{ mA}$
• Input resistance	40 k Ω relative to frame
• Hardware smoothing	220 μs
• Resolution	13 bits + sign bit
Analog output	AO1, AO2, AOM
• Voltage range	$\pm 10 \text{ V}$
• Input resistance	40 k Ω relative to frame
• Hardware smoothing	10 μs
• Resolution	11 bits + sign bit

Selection and ordering data

Description	Order No.:
EB1 Terminal expansion board	6SX7010-0KB00

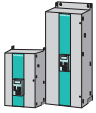

SIMOREG 6RA70 DC MASTER

Options

Terminal expansions

Terminal expansion board EB2

The number of digital and analog inputs and outputs can be expanded with terminal expansion board EB2 (Expansion-Board 2).

On terminal expansion board EB2, there are:

- 2 digital inputs
- 1 relay output with changeover contacts
- 3 relay outputs with NO contacts
- 1 analog input with differential signal, for use as current or voltage input
- 1 analog output
- 24 V supply for the digital outputs.

Terminal expansion board EB2 is installed in a slot in the electronics box.

Boards LBA and ADB must be moved to allow installation.

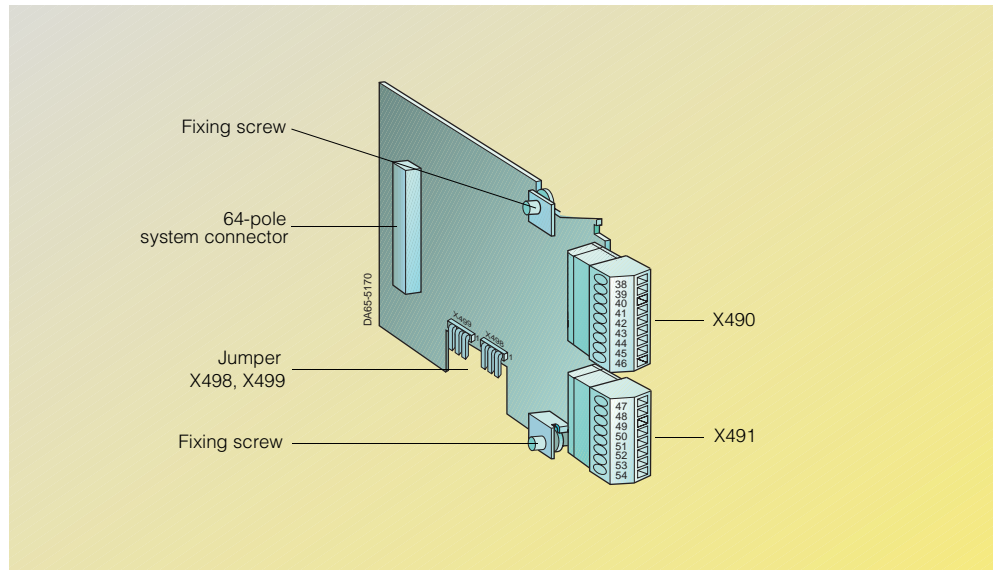

Fig. 4/12
Terminal expansion board EB2

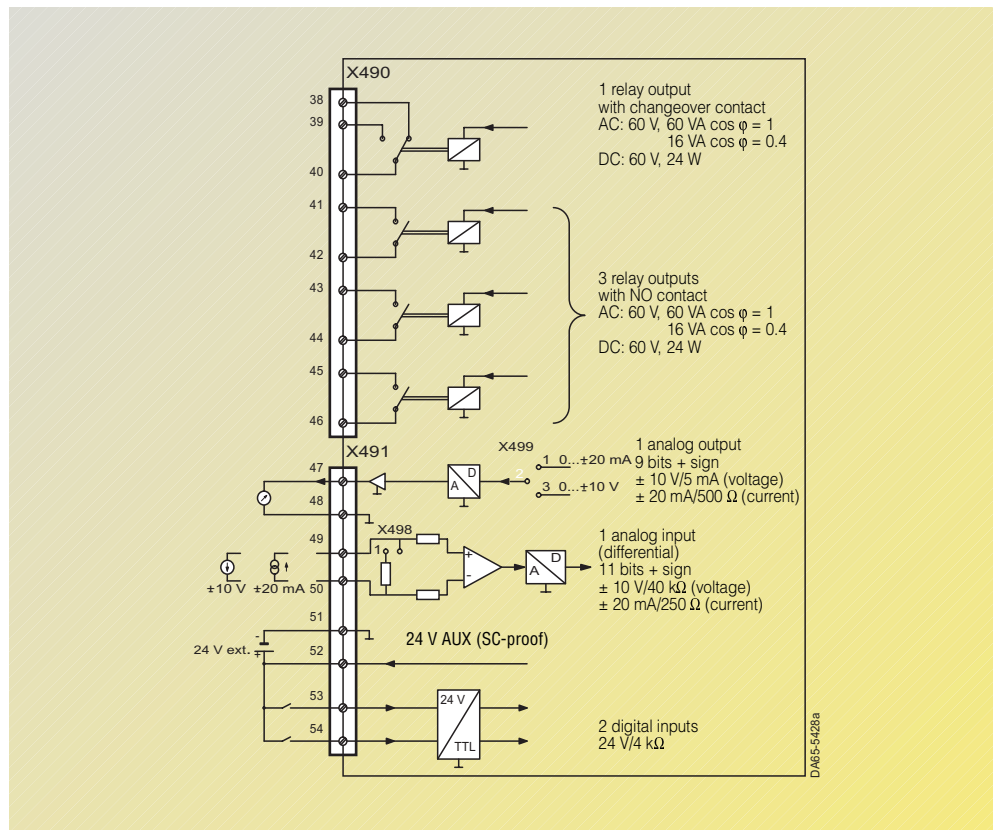
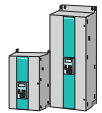

Fig. 4/13
Circuit diagram of the terminal expansion board EB2

SIMOREG 6RA70 DC MASTER

Options



Terminal expansions

Terminal expansion board EB2

Terminal X490

Load rating on the relay contacts	
Contact type	Changeover
Max. operational voltage	60 V AC, 60 V DC
Max. switching power	16 VA at 60 V AC ($\cos \varphi = 0.4$)
	60 VA at 60 V AC ($\cos \varphi = 1.0$)
	3 W at 60 V DC
	24 W at 60 V DC

Terminal	Designation	Meaning
38	DO13	Relay output 1, NC
39	DO12	Relay output 1, NO
40	DO11	Relay output 1, reference contact
41	DO22	Relay output 2, NO
42	DO21	Relay output 2, reference contact
43	DO32	Relay output 3, NO
44	DO31	Relay output 3, reference contact
45	DO42	Relay output 4, NO
46	DO41	Relay output 4, reference contact

Connectable cross-section: 0.14 - 1.5 mm² (AWG 16)

Terminal X491

The ground cables are protected with a reactor.

Note

The analog input can be used as a voltage or current input. This is set using a jumper.

Terminal	Designation	Meaning	Range
47	AO	Analog output	± 10 V, 5 mA
48	AOM	Analog output ground	± 20 mA, 500 Ω
49	AI1P	Analog input +	± 10 V, 40 k Ω
50	AI1N	Analog input -	± 20 mA, 250 Ω
51	DIM	Digital input ground	0 V
52	P24AUX	24 V supply	24 V
53	DI1	Digital input 1	24 V, $R_i = 4$ k Ω
54	DI2	Digital input 2	24 V, $R_i = 4$ k Ω

Connectable cross-section: 0.14 - 1.5 mm² (AWG 16)

Technical Data

Designation	Value
Digital inputs	DI1, DI2, DIM
<ul style="list-style-type: none"> Voltage range LOW Voltage range HIGH Input resistance Smoothing Isolation 	0 V (-33 V to +5 V)
	+24 V (13 V to 33 V)
	4 k Ω
	250 μ s
	None
Digital outputs (relay)	DO1., DO2., DO3., DO4.
<ul style="list-style-type: none"> Contact type Max. operational voltage Max. switching power 	Changeover
	60 V AC, 60 V DC
	16 VA ($\cos \varphi = 0.4$)
	60 VA ($\cos \varphi = 1.0$)
	3 W
<ul style="list-style-type: none"> Permissible minimum capacity 	1 mA, 1 V
	24 W
	24 W
Analog input (differential input)	AI1P, AI1N
<ul style="list-style-type: none"> Input range 	Voltage
	± 11 V
<ul style="list-style-type: none"> Current 	± 20 mA
	<ul style="list-style-type: none"> Input resistance
40 k Ω relative to frame	
<ul style="list-style-type: none"> Current 	250 Ω relative to frame
	<ul style="list-style-type: none"> Hardware smoothing Resolution
11 bits + sign bit	
10 μ s	
Analog output	AO, AOM
<ul style="list-style-type: none"> Voltage range Input resistance Hardware smoothing Resolution 	± 10 V, ± 0 -20 mA
	40 k Ω relative to frame
	10 μ s
	9 bits + sign bit

Selection and ordering data

Description	Order No.:
EB2 Terminal expansion board	6SX7010-0KC00

4

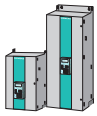

Interface boards SCI1 and SCI2

Interface boards SCI1 or SCI2 (**S**erial **C**ommunication **I**nterface 1 or 2) and interface board SCB1 can be used to assemble a serial I/O system with a fiber-optic conductor that can expand the binary and analog inputs and outputs considerably. In addition, the fiber-optic conductor reliably decouples the devices according to DIN VDE 0100 and DIN VDE 0160 (PELV function, e.g. for NAMUR).

The fiber-optic conductor of between 0.3 m and 10 m in length connects the modules in a ring. Both the SCI1 and the SCI2 require an external 24 V supply (1 A each).

All inputs and outputs of the interface boards can be parameterized.

Interface boards SCI1 and SCI2 can be snapped onto a mounting rail at a suitable location in the switchgear cabinet.



Fig. 4/14
Interface board SCI1

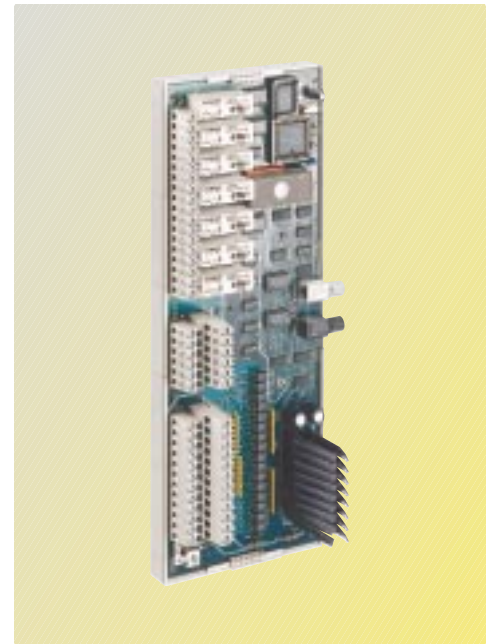

Fig. 4/15
Interface board SCI2

Inputs and outputs

Functions	SCI1	SCI2	Description
Binary inputs	10	16	Isolated optocoupler inputs in 2 circuits 24 V DC, 10 mA
Binary outputs of which	8	12	Load rating:
Relay changeover	4	4	250 V AC, 2000 VA (cosφ = 1)
Relay NO	3	3	100 V DC, 240 W
Transistor outputs	1	5	240 V DC, max. 100 mA, short-circuit-proof, open emitter for controlling optocouplers or relay
Analog inputs	3	–	Voltage signals: 0 to ± 10 V Current signals: 0 to ± 20 mA; 4 to 20 mA; 250 Ω resistive load Non-floating inputs
Analog outputs	3	–	Output signals: 0 to ± 10 V, 0 to ± 20 mA, 4 to 20 mA Non-floating Max. cable length 100 m with shielded cable Max. resistive load 500 Ω
Supply voltage:			
Reference voltage			
+10 V	1	–	Load rating 5 mA short-circuit proof
-10 V	1	–	Load rating 5 mA short-circuit proof
24 V DC	2	2	Short-circuit proof output for binary inputs or outputs, load rating 280 mA

Technical Data

Fixing	Standard mounting rail
Rated input voltage, external	24 V DC (-17 %, +25 %), 1 A
Degree of protection	IP 00
Dimensions H x W x D	SCI1: 95 mm x 300 mm x 80 mm SCI2: 95 mm x 250 mm x 80 mm

SIMOREG 6RA70 DC MASTER

Options

Terminal expansions



Control terminal strip on interface board SCI1

Terminal	No.:	Internal Circuit	Function, Notes
X427	A1		Auxiliary voltage P 24 V DC, 200 mA for binary inputs
	A2		Auxiliary voltage M for binary inputs
	A3		Binary input 6
	A4		Binary input 7
	A5		Binary input 8
	A6		Binary input 9
	A7		Binary input 10
	A8		Reference point for binary inputs 6 to 10
	A9		Auxiliary voltage M for binary inputs
	A10		Power supply M (connection of external supply)
	A11		Power supply M (connection of external supply)
	B1		Binary output 8, driver P 24 V DC
	B2		Binary output 8, driver 100 mA external, short-circuit proof
	B3		Binary input 1
	B4		Binary input 2
	B5		Binary input 3
	B6		Binary input 4
	B7		Binary input 5
B8	Reference point for binary inputs 1 to 5		
B9	Auxiliary voltage P 24 V DC for binary inputs		
B10	Power supply P 24 V DC (connection of external supply)		
B11	Power supply P 24 V DC (connection of external supply)		
X428	1	—	+10 V / 5 mA for potentiometer; short-circuit proof
	2	—	-10 V / 5 mA for potentiometer; short-circuit proof
	3		Analog input 1: Voltage (0 to +/-10 V)
	4		Ground
	5		Current (0/4 to 20 mA, resistive load 250 Ω)
	6		Analog input 2: Voltage (0 to +/-10 V)
	7		Ground
	8		Current (0/4 to 20 mA, resistive load 250 Ω)
	9		Analog input 3: Voltage (0 to +/-10 V)
	10		Ground
	11		Current (0/4 to 20 mA, resistive load 250 Ω)
	12		Analog output 1: Ground
13		Voltage (0 to +/-10 V, max. 5 mA)	
14		Current (0/4 to +/-20 mA, max. 500 Ω)	
15		Analog output 2: Ground	
16		Voltage (0 to +/-10 V, max. 5 mA)	
17		(0/4 to +/-20 mA, max. 500 Ω)	
18		Analog output 3: Ground	
19		Voltage (0 to +/-10 V, max. 5 mA)	
20		Current (0/4 to +/-20 mA, max. 500 Ω)	

4

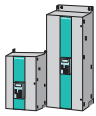

SIMOREG 6RA70 DC MASTER

Options

Terminal expansions

Control terminal strip on interface board SCI1

Terminal	No.:	Internal Circuit	Function, Notes
X429	1		Binary output 1:
	2		NO 100 V DC / 250 V AC; 240 W / 2000 VA; min.: 24 V, 10 mA
	3		Binary output 2:
	4		NO 100 V DC / 250 V AC; 240 W / 2000 VA; min.: 24 V, 10 mA
	5		Binary output 3:
	6		NO 100 V DC / 250 V AC; 240 W / 2000 VA; min.: 24 V, 10 mA
	7		Binary output 4:
	8		changeover
	9		100 V DC / 250 V AC; 240 W / 2000 VA; Minimum load: 24 V, 10 mA
	10		Binary output 5:
	11		changeover
	12		100 V DC / 250 V AC; 240 W / 2000 VA; Minimum load: 24 V, 10 mA
	13		Binary output 6:
	14		changeover
	15		100 V DC / 250 V AC; 240 W / 2000 VA; Minimum load: 24 V, 10 mA
	16		Binary output 7:
	17		changeover
	18		100 V DC / 250 V AC; 240 W / 2000 VA; Minimum load: 24 V, 10 mA

Control terminal strip on interface board SCI2

Terminal	No.:	Internal Circuit	Function, Notes
X437	A1		Binary input 9
	A2		Binary input 10
	A3		Binary input 11
	A4		Binary input 12
	A5		Binary input 13
	A6		Binary input 14
	A7		Binary input 15
	A8		Binary input 16
	A9		Reference point for binary inputs 9 to 16
	A10		Auxiliary voltage M for binary inputs
	A11		Power supply M (connection of external supply)
	A12		Power supply M (connection of external supply)
	B1		Binary input 1
	B2		Binary input 2
	B3		Binary input 3
	B4		Binary input 4
	B5		Binary input 5
	B6		Binary input 6
	B7		Binary input 7
	B8		Binary input 8
	B9		Reference point for binary inputs 1 to 8
	B10		Auxiliary voltage P 24 V DC, 280 mA/0 to 40 °C, 400 mA/20 °C, 200 mA/55 °C in combination with X438/A5 for binary
	B11		Power supply P 24 V DC (connection of external supply)
	B12		Power supply P 24 V DC (connection of external supply)

SIMOREG 6RA70 DC MASTER

Options

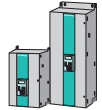

Terminal expansions

Control terminal strip on interface board SCI2

Terminal	No.:	Internal Circuit	Function, Notes
X438	A1		Binary output 11, driver 24 V DC
	A2		Binary output 11, driver 100 mA external, short-circuit proof
	A3		Binary output 12, driver 24 V DC
	A4		Binary output 13, driver 100 mA external, short-circuit proof
	A5	—	Auxiliary voltage P 24 V DC, 280 mA/0 to 40 °C, 400 mA/20 °C, 200 mA/55 °C in combination with X437/B10 for binary
	A6	—	Auxiliary voltage M for binary outputs
	B1		Binary output 8, driver 24 V DC
	B2		Binary output 8, driver 100 mA external, short-circuit proof
	B3		Binary output 9, driver 24 V DC
	B4		Binary output 9, driver 100 mA external, short-circuit proof
	B5		Binary output 10, driver 24 V DC
	B6		Binary output 10, driver 100 mA external, short-circuit proof
X439	1		Binary output 1: NO 100 V DC / 250 V AC;
	2		240 W / 2000 VA; min.: 24 V, 10 mA
	3		Binary output 2: NO 100 V DC / 250 V AC;
	4		240 W / 2000 VA; min.: 24 V, 10 mA
	5		Binary output 3: NO 100 V DC / 250 V AC;
	6		240 W / 2000 VA; min.: 24 V, 10 mA
	7		Binary output 4: changeover
	8		100 V DC / 250 V AC; 240 W / 2000 VA;
	9		Minimum load: 24 V, 10 mA
	10		Binary output 5: changeover
	11		100 V DC / 250 V AC; 240 W / 2000 VA;
	12		Minimum load: 24 V, 10 mA
	13		Binary output 6: changeover
	14		100 V DC / 250 V AC; 240 W / 2000 VA;
	15		Minimum load: 24 V, 10 mA
	16		Binary output 7: changeover
	17		100 V DC / 250 V AC; 240 W / 2000 VA;
	18		Minimum load: 24 V, 10 mA

Selection and ordering data

Description	Order No.:
SCI1 Interface board Binary and analog inputs/outputs Supplied unassembled incl. 10 m fiber-optic cable	6SE7090-0XX84-3EA0
SCI2 Interface board Binary inputs and outputs Supplied unassembled incl. 10 m fiber-optic cable	6SE7090-0XX84-3EF0

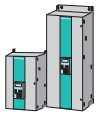

Technology board T400

The T400 is used to implement supplementary process-specific functions (e.g. for tension and position controls, winders, reels, synchronous and positioning controls, hoisting gear and drive-related open-loop control functions). Frequently used supplementary process-specific functions are available as pre-programmed standard configurations.

End users who wish to implement specialist applications or who want to market their own technological know-how can create their own process solution on the T400 using CFC configuring language that is familiar from SIMATIC® STEP® 7.

Process-specific functions are configured with CFC. The processor then executes these functions cyclically. The closed-loop control sampling time is about 1 ms.

A virtually instantaneous parallel interface (dual-port RAM) allows data to be exchanged between the basic unit and T400. All signals can be directly connected to terminals on the T400. A 15 V/100 mA pulse power supply is available.

An external 24 V DC supply must be available to drive the binary inputs and outputs. This voltage can be supplied by the basic unit provided the total current at the terminals does not exceed 150 mA.

The configuration is parameterized by means of:

- The PMU operation and parameterization unit
- The OP1S operator control panel
- A PC with DriveMonitor¹⁾ on the basic unit
- An interface board
- Altered parameter settings can be stored permanently in the EEPROM.

The T400 board can be installed in the electronics box of SIMOREG converters. The LBA bus adapter is needed for this purpose.

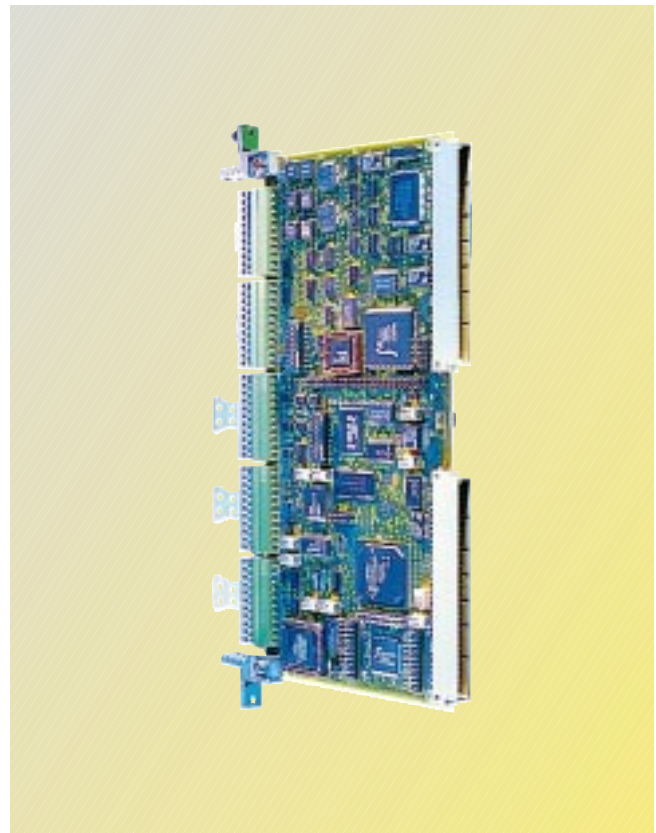

Fig. 4/16
Technology board T400

1) The DriveMonitor service program enables the entire parameter set of a standard configuration to be read or written via a PC or programming device.



Technology boards

Technology board T400

Features (inputs/outputs)

- 2 analog outputs
- 5 analog inputs
- 2 binary outputs
- 8 binary inputs
- 4 bidirectional binary inputs or outputs
- 2 incremental encoder inputs with zero pulse
 - Encoder 1 for HTL (15 V) encoder.
 - Encoder 2 for HTL (15V) or TTL/RS 422 encoder (5 V)
- For each incremental encoder: One coarse pulse input for suppression of zero pulse, coarse pulse inputs (simultaneous) also available as binary inputs
- No isolation of inputs/outputs.
- Serial interface 1 with RS 232 and RS 485 transmission format; protocol can be selected via switch on board:
 - Service protocol DUST1 with 19.2 Kbits/s and RS 232 transmission format
 - USS protocol, 2-wire with selectable RS 232 or RS 485 transmission format, max. 38.4 Kbits/s, configurable as slave for parameterization with OP1S, Drive ES Basic or SIMOVIS or as master for OP2 operator panel connection
- Serial interface 2 with RS 485 transmission format and protocol that is selectable through configuring of the appropriate function block:
 - Peer-to-peer for high-speed process link, 4-wire.
 - USS protocol configurable as slave for parameterization with OP1S, Drive ES Basic or DriveMonitor (2-wire or 4-wire) baudrates [Kbits/s]: 9.6/19.2/38.4/93.75/187.5.

Note

If serial interface 2 (peer-to-peer, USS) is used, the second absolute encoder cannot be operated since both applications utilize the same terminals.

- Absolute encoder 1 with SSI or EnDat protocol (RS 485) for positioning applications.
- Absolute encoder 2 with SSI or EnDat protocol (RS 485) for positioning applications.

Note

If the second absolute encoder is used, serial interface 2 (peer-to-peer, USS) cannot be used since both applications utilize the same terminals.

- Wide variety of synchronizing options:
 - Synchronization of T400 with MASTERDRIVES (CUx, CBx) or second T400
 - T400 supplies synchronizing signals for MASTERDRIVES (CUx, CBx) or second T400.
- Operation without a fan
- 3 LEDs for operational status displays.
- Hardlock PAL: Plug-in base for 28-pin EPLD submodule as copy protection for user program (as on 32-bit CPU boards).
- Soldered-in flash memory (2 MB) for downloadable program code (no MS5x memory module needed).
- 4 MB DRAM as main memory for program and data.
- 32 KB permanent modification memory.
- 128 byte NOVRAM for data storage during power off.
- Cache: 4 KB program, 4 KB data.
- Clock cycle (external/internal): 32/32 MHz.

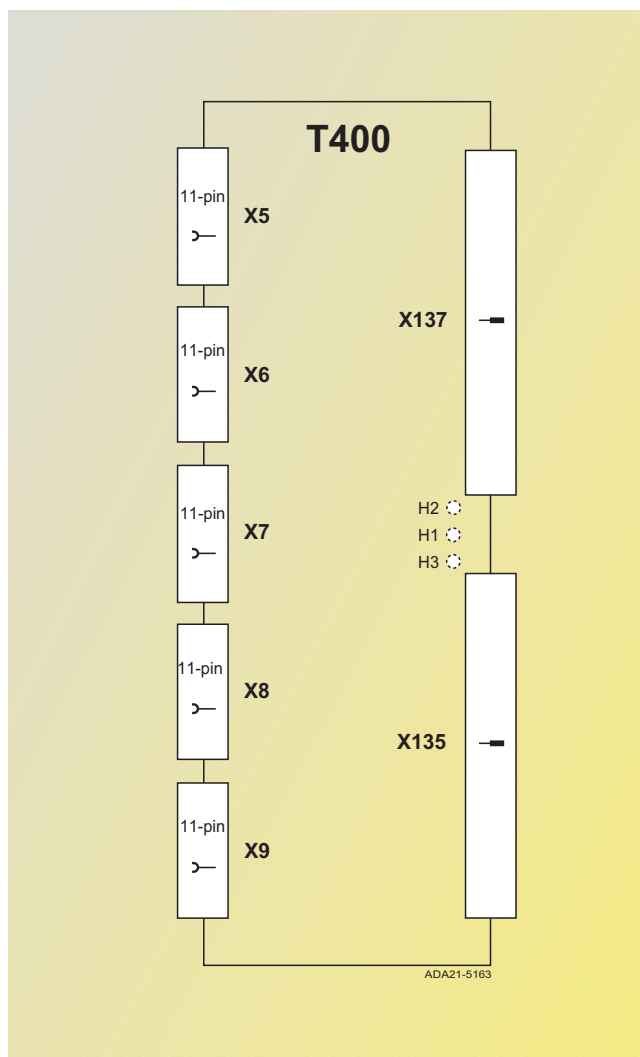
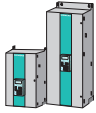

Fig. 4/17
Technology board T400



SIMOREG 6RA70 DC MASTER

Options

Technology boards

Technology board T400

Type	Features	
General	Isolation of inputs/outputs. Space required Dimensions (W x H x D) in mm Weight	No 1 slot 267 x 140 x 14 0.4 kg
Power supply	Voltage supply/typ. power consumption	+ 5 V \pm 5 %: 1.1 A +15 V \pm 4 %: 140 mA + max. 100 mA encoder supply -15 V \pm 3 %: 140 mA
Analog outputs	Number Output range Short-circuit protection Short-circuit current Resolution Accuracy, absolute Linearity error Voltage rise time Delay time	2 \pm 10 V Yes \pm 10 mA 12 bits (4.88 mV) \pm 3 bits < 1 bit 4.2 V/ μ s 3.5 μ s
Analog inputs	Number Input range Measuring principle Conversion time Input impedance Input filter (-3 dB limit frequency) Resolution Accuracy, absolute Linearity error	2 differential inputs, 3 unipolar \pm 10 V Sampling 12 μ s 20 k Ω 1.5 kHz 12 bits (4.88 mV) \pm 3 bits < 1 bit
Binary outputs	Number Ext. Supply voltage: •Rated value •Permissible range •For "0" signal •For "1" signal Output current Output current, ext. Supply voltage Switching frequency/ohmic load Overload protection Max. switching delay	2 + max. 4 (bidirect.) 24 V DC 15 to 33 V DC Max. 0.1 V Ext. supply voltage -0.3 V Max. 50 mA/output 50 mA + output currents 5 kHz Yes (limited to 100 mA) 70 μ s
Binary inputs and coarse signals	Number Input voltage: •Rated value •For "0" signal •For "1" signal	8 + max. 4 (bidirect.) + max. 2 (coarse pulse) 24 V DC -1 to +6 V or input open +13 to +33 V
Input current	Input current: •For "0" signal •For "1" signal Input smoothing (time constant)	- 8 mA typ. 0.1 ms
5 V, 15 V incremental encoder	Number Signal voltage (rated value): •"Encoder 1" •"Encoder 2" Max. pulse frequency Input filter	2 15 V (HTL only) unipolar 5 V or 15 V unipolar or differential 1.5 MHz Configurable on function block (NAV)
5 V incremental encoder	Signal voltage for differential inputs (RS 422 encoder): •For "0" signal •For "1" signal Signal voltage for unipolar inputs (TTL encoder): •For "0" signal •For "1" signal Input current	 ->0.2 V >0.2 V < 0.8 V > 2.3 V 15 mA (limited)
15 V incremental encoder	Signal voltage for differential inputs •For "0" signal •For "1" signal Signal voltage for unipolar inputs: •For "0" signal •For "1" signal Input current	 -30 V to 4 V 8 V to 30 V < 5 V > 8 V 15 mA (limited)
Absolute encoder	Number of connectable encoders Signal voltage Data transfer rate Data display	Max. 2 Single-turn or multi-turn encoder With SSI (synchronous-serial) or EnDat interface 5 V to RS 422 100 kHz to 2 MHz Dual, Gray, Gray Excess Code

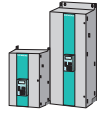

Technology boards

Technology board T400

Standard configurations

Standard configurations for commonly used application types are available as pre-installed configurations. The standard configuration can be adapted to suit a specific plant by means of parameterization.

Components and features of standard configuration

- Peer-to-peer communication (digital setpoint cascade)
- The T400 with standard configuration can be operated with and without a communication board (e.g. CBP)

A communication board can be used to

1. Specify T400 control commands and set points via a bus system (e.g. PROFIBUS-DP) or a point-to-point connection
 2. Read actual values and status words and to read and write technology parameters
- Inputs, outputs and process data can be "wired up" to the DRAM to provide access to all important SIMOREG data, thereby ensuring highly flexible configuring
 - Non-volatile storage of all important operating data
 - All parameters can be reset to IPL status
 - Parameters can be set via PC with DriveMonitor linked to the basic unit interface

Available standard configurations

- Standard configuration for axial winders
- Standard configuration for angular synchronism controls

Standard configuration for axis winder with T400

Scope of applications:

- Foil plants
- Paper machines
- Paper finishing machines
- Coating machines
- Printing presses of all types (foil, paper)
- Wire-drawing machines
- Reels in metalworking (e.g. straightening machines, treatment plants, etc.)

Features

- Suitable for wind-on and wind-off coils, with and without on-the-fly roller change
- Suitable for direct and indirect tension control
- Compensating roller or tension capsule-type dynamometer can be connected
- Diameter calculation with "Set diameter" and "Stop" plus non-volatile storage of diameter measurement
- Adaptation of tension and speed controllers as a function of diameter
- Polygon-based friction compensation, speed-dependent
- Acceleration as a function of diameter, material width and gear stage
- Ramp-function generator for acceleration on on-the-fly roller change followed by shutdown
- Pulse encoder for path velocity measurement can be connected
- Initial diameter can be measured via contact pulse encoder
- Tension controller can be applied either to the speed controller or directly to the torque control
- $V = \text{constant}$ control can be implemented
- Winder-specific open-loop control with alarm and fault evaluation
- Inching and crawling operation
- Two motorized potentiometers for optional use
- Smooth, overshoot-free shutdown via braking characteristic

Standard configuration for angular synchronism control with T400

Scope of applications:

- Substitute for mechanical and electrical shafts, e.g. on gantry traversing mechanisms, feed and discharge machines on furnaces or looms
- Substitute for gear units with fixed or variable gear ratio, e.g. change-gear units, installed at transition points on conveyor belts or at transition point between one machine section and the next, such as on packaging machines or book spine gluing machines
- Phase-locked synchronism, also applicable for mutual engagement of two machine parts. Also suitable for printing or folding of bags, round stock, etc.

Features

- Angular synchronism with gear ratio adjustable within wide limits
- Offset angle setting between drives as a function of coarse and fine pulse markers for angle sensing (synchronization)
- Synchronization signals can be supplied by proximity-type switches (e.g. BERO[®]s) or pulse encoders (zero pulse)
- Modification of angle setting by setpoint input
- Different offset angles can be specified for both directions of rotation (automatic switchover on direction reversal). This option must be applied for synchronization if the switching positions of the fine pulse marker are different for clockwise and anti-clockwise rotation of the drive (or machine part acting as the synchronization partner) and need to be compensated. Another example is a crane runway on which the fine pulse marker is two-dimensional.
- Backstop function
- Overspeed and blocking protection
- Inching operation
- Adaptation of position controller based on gear ratio

- Setpoint (speed setpoint) can be supplied by pulse encoder, for example, in cases where the speed setpoint is not available via a terminal or interface

- A maximum of ten slave drives can be connected if pulse encoder cable length $< 100 \text{ m}$, $n < 3\,000 \text{ min}^{-1}$

Closed-loop cross-cutter/shears control

Scope of applications:

- Flying saw/knife
- Rotating cross-cutter (drum shears)

Features

- Local control modes
 - Inch 1/2
 - Calibrate
 - Approach start position
 - Parameterizable angular ranges for synchronism
- Cutter control modes
 - Single cut to separate the material
 - Head cut to separate defective length at start of material
 - End cut to separate defective length at end of material
 - Continuous lengthwise cuts for chopping or panel cutting
 - Trial cut for cutting a panel
 - Cutting program with entry of number and length of cuts
- Referencing
- Error monitoring
- Overspeed for setting the lead
- Format changeover from one cut to the next
- Gentle traversing curves (sin/cos) to enhance the cutting accuracy and protect the mechanical components
- Closed-loop format control to optimize the cutting precision
- Cutting curve to optimize the cutting accuracy
- KP-adaption speed control for enhancing the cutting accuracy
- Compensation of variable inertia (pendulum torque), e.g. for pendulum shears
- Friction compensation
- Torque precontrol for acceleration
- Cutting torque application

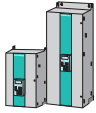

SIMOREG 6RA70 DC MASTER

Options

Technology boards

Technology board T400

T400 terminal assignments	Connector	Connector pin	Terminal	
+24 V external (for binary inputs and outputs)	X5	1	45	
Bidirectional binary input and output 1		2	46	
Bidirectional binary input and output 2		3	47	
Bidirectional binary input and output 3		4	48	
Bidirectional binary input and output 4		5	49	
Ground for binary inputs and outputs		6	50	
Binary output 1		7	51	
Binary output 2		8	52	
Binary input 1 (alarm-capable)		9	53	
Binary input 2 (alarm-capable)		10	54	
Binary input 3 (alarm-capable)		11	55	
Binary input 4 (alarm-capable)	X6	1	56	
Binary input 5		2	57	
Binary input 6		3	58	
Binary input 7		4	59	
Binary input 8		5	60	
Ground for binary inputs and outputs		6	61	
Increm. encoder 2: Track A (HTL)		Increm. encoder 2: Track A+ (RS 422)	7	62
Increm. encoder 2: Track B (HTL)		Increm. encoder 2: Track B+ (RS 422)	8	63
Increm. encoder 2: Zero pulse (HTL)		Increm. encoder 2: Zero pulse+ (RS 422)	9	64
Increm. encoder 2: Coarse pulse			10	65
Ground for increm. encoder 2			11	66
Ser. interface 1: Rx-RS 232	X7	1	67	
Ser. interface 1: Tx-RS 232		2	68	
Ground for ser. interface		3	69	
Ser. interface 1: Tx/Rx-RS 485+		4	70	
Ser. interface 1: Tx/Rx-RS 485-		5	71	
Ser. interface 2: Rx-RS 485+		Absolute encoder 2: Data+	6	72
Ser. interface 2: Rx-RS 485-		Absolute encoder 2: Data-	7	73
Ser. interface 2: Tx (Rx)-RS 485+		Absolute encoder 2: Clock+	8	74
Ser. interface 2: Tx (Rx)-RS 485-		Absolute encoder 2: Clock-	9	75
Absolute encoder 1: Data+			10	76
Absolute encoder 1: Data-			11	77
Absolute encoder 1: Clock+	X8	1	78	
Absolute encoder 1: Clock-		2	79	
+15 V encoder supply (max. 100 mA)		3	80	
Increm. encoder 1: Track A		4	81	
Increm. encoder 1: Track B		5	82	
Increm. encoder 1: Zero pulse		6	83	
Increm. encoder 1: Coarse pulse		7	84	
Ground for increm. encoder 1		8	85	
Increm. encoder 2: Track A- (with RS 422)		9	86	
Increm. encoder 2: Track B- (with RS 422)		10	87	
Increm. encoder 2: Zero pulse- (with RS 422)		11	88	
Ground for analog inputs and outputs	X9	1	89	
Analog input 1		Analog input 1+	2	90
		Analog input 1-	3	91
Analog input 2		Analog input 2+	4	92
		Analog input 2-	5	93
Analog input 3			6	94
Analog input 4			7	95
Analog input 5			8	96
Analog output 1			9	97
Analog output 2			10	98
Ground for analog inputs and outputs			11	99

4

Selection and ordering data

Description	Order No.:	Order No.:	Order No.:	Order No.:
		German	German/English	English
T400 with axle winder without User's Guide	6DD1842-0AA0	–	–	–
Axle winder software including User's Guide	6DD1843-0AA0	–	–	–
User's Guide for axle winder	–	6DD1903-0AA0	–	6DD1903-0AB0
T400 with angular synchronism without User's Guide	6DD1842-0AB0	–	–	–
Angular synchronism software including User's Guide	6DD1843-0AB0	–	–	–
User's Guide for angular synchronism	–	6DD1903-0BA0	–	6DD1903-0BB0
T400 technology board including brief description	6DD1606-0AD0	–	–	–
User's Guide	–	–	6DD1903-0EA0	–
T400 with closed-loop cross-cutter/shears control	6DD1842-0AD0	–	–	–
Software for closed-loop cross-cutter/shears control including User's Guide	6DD1843-0AC1	–	–	–
User's Guide	–	6DD1903-0DA0	–	6DD1903-0DB0

SIMOREG 6RA70 DC MASTER

Options

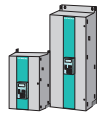

Technology boards

Technology board T100

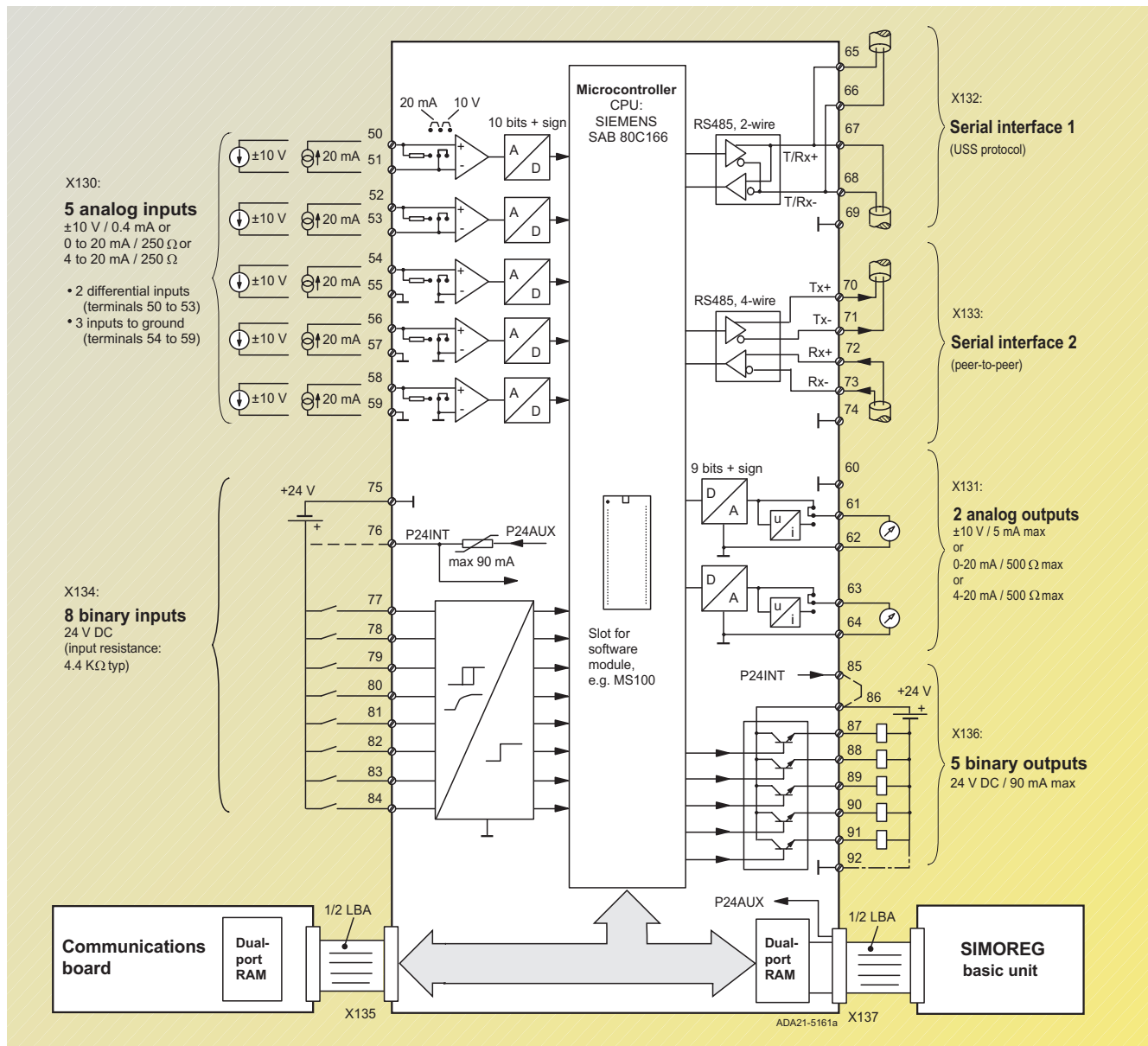

Fig. 4/18
Connection diagram for T100

T100 technology board

The T100 board can be installed in the electronics box of SIMOREG converters. The LBA bus adapter is needed for this purpose.

The T100 board extends the basic converter functionality by many drive-related technological functions such as:

- Higher-level PID controller for use, for example, as a tension, compensating roller position, flow or pressure controller.

- Comfort ramp-function generator with rounding, parameter set selection via control command, dv/dt output and cut-out function.
- Comfort motorized potentiometer with non-volatile storage of output value.
- Wobble generator with triangular wobble pattern, adjustable P steps and synchronizing input or output for reciprocating drives.

- Drive-specific control functions, e.g. starting/shutdown controller.
- Terminals with 8 binary inputs, 5 binary outputs, 5 analog inputs and 2 analog outputs. All external signals are connected directly to screw-type plug-in terminals 50 to 92 on the T100 board.

- 2 serial interfaces that can operate in mutual independence:
 - High-speed peer-to-peer link with a transfer rate of up to 187.5 kbd, with which a digital setpoint cascade can be created.
 - USS interface with a transfer rate of up to 187.5 kbd, for implementing a simple fieldbus connection to the SIMATIC PLC or an external system.

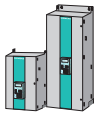

SIMOREG 6RA70 DC MASTER

Options

Technology boards

Technology board T100

Technical data

In addition to the functions listed above, the T100 contains a series of freely interconnectable closed-loop control, arithmetic and logic blocks:

- 5 adders with 3 inputs each
- 3 subtractors
- 4 sign inverters
- 3 dividers
- 4 multipliers
- 3 high-resolution multipliers/dividers with 3 inputs
- 4 absolute-value generators with filter
- 2 limiters
- 2 limit-value monitors with filter
- 1 minimum selection with 3 inputs
- 1 maximum selection with 3 inputs
- 2 analog signal tracking/storage elements with non-volatile storage on power failure
- 2 analog signal storage elements
- 10 analog signal selector switches
- 1 simple ramp-function generator
- 1 dead band
- 3 characteristic blocks
- 16 AND elements with 3 inputs each
- 8 OR elements with 3 inputs each
- 8 inverters
- 3 EXCLUSIVE OR elements
- 6 NAND elements with 3 inputs each
- 7 RS flipflops
- 2 D storage elements
- 5 timers
- 4 binary signal selector switches
- 1 parameter set switchover

Terminal	Features
5 analog inputs	<ul style="list-style-type: none"> • Possible input level/input impedance <ul style="list-style-type: none"> – -10 V ... + 10 V/24 kΩ typ – 0 ... ± 20 mA/250 Ω typ – 4 ... 20 mA/250 Ω typ • 2 differential inputs • 3 inputs to ground • Non-floating • Resolution 10 bits + sign
2 analog outputs	<ul style="list-style-type: none"> • Possible output level/driver capability <ul style="list-style-type: none"> – -10 V to + 10 V/5 mA max. – 0 to 20 mA/500 Ω max. – 4 to 20 mA/500 Ω max. • Non-floating • Resolution 9 bits + sign
8 binary inputs	<ul style="list-style-type: none"> • Input level 24 V DC, compatible with SIMATIC: <ul style="list-style-type: none"> LOW = -33 V to +5 V, HIGH = +13 V to +33 V • Non-floating • Input resistance: 4.4 kΩ typ • Signal status display on PMU and OP1S
5 binary outputs	<ul style="list-style-type: none"> • Transistor switch, switched in relation to 24 V DC, "open emitter" • Output level compatible with SIMATIC: <ul style="list-style-type: none"> LOW < +2 V, HIGH +17.5 to +33 V • Switching capacity: 90 mA max. (resistant to sustained short circuits) • Signal status display on PMU and OP1S
24 V DC load power supply for binary inputs and outputs	<ul style="list-style-type: none"> • From SIMOREG converter: A short-circuit-proof 24 V DC supply is available at terminals 76 and 85 which has a total load rating of 90 mA. • External 24 V DC supply: Permissible voltage range +20 to +30 V
1 peer-to-peer interface	<ul style="list-style-type: none"> • RS 485 transmission method, 4-wire full duplex • Non-floating • Terminating resistances can be activated by jumpers • Settable baud rate up to 187.5 Kbd • Receive and send signals can be freely interconnectable by parameters • Max. cable length for 187.5 kbd: 500 m, For other baud rates 1000 m
1 serial USS interface	<ul style="list-style-type: none"> • RS 485 transmission method, 2-wire half duplex • Non-floating • Terminating resistances can be activated by jumpers • Settable baud rate up to 187.5 Kbd • Max. cable length for 187.5 kbd: 500 m, For other baud rates 1000 m

Communications functions

It is possible to access important internal signals and parameters of both the basic converter and T100 via the USS interface on the basic unit or the T100 board.

The access method and reactions of the T100 are identical to those of the SIMOREG basic unit.

The T100 has its own parameter memory and can be parameterized via the PMU operator control and parameterization panel, the OP1S operator panel or a PC with SIMOVIS installed.

The PC with SIMOVIS is connected to the USS interface on the SIMOREG unit.

All important internal signals of the T100 can be monitored by means of display parameters (multimeter function).

The T100 features three diagnostic LEDs which indicate the following operating states:

1. T100 is operating correctly in cyclical mode.
2. Data exchange between T100 and SIMOREG is OK.
3. Data exchange between T100 and the communication board is OK.

Note

All the software functions described here are contained in the MS100 "Universal Drive" software module. The module is a 40-pin EPROM submodule that must be ordered separately and inserted in the specially provided receptacle on the T100 board.

Selection and ordering data

Description	Order No.:	Weight (approx.) kg	Dimensions W x H x D mm
T100 Technology board T100 for drive-based technological functions. For further details, integration of the T100 board and accessories, see Catalog DA 65.10 SIMOVERT MASTERDRIVES Vector Control. Supplied unassembled without software modules.	6SE7090-0XX87-0BB0	0.5	25 x 235 x 125

SIMOREG 6RA70 DC MASTER

Options

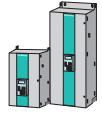

Technology boards

T300 technology board

This board allows additional technological functions to be implemented. For a comprehensive description of the functional scope of this board, see Catalog DA 65.10 SIMOVERT MASTERDRIVES Vector Control.

- 16 binary inputs and 8 binary outputs
- 7 analog inputs and 4 analog outputs
- 2 serial interfaces
- Customized configuration using STRUC®.

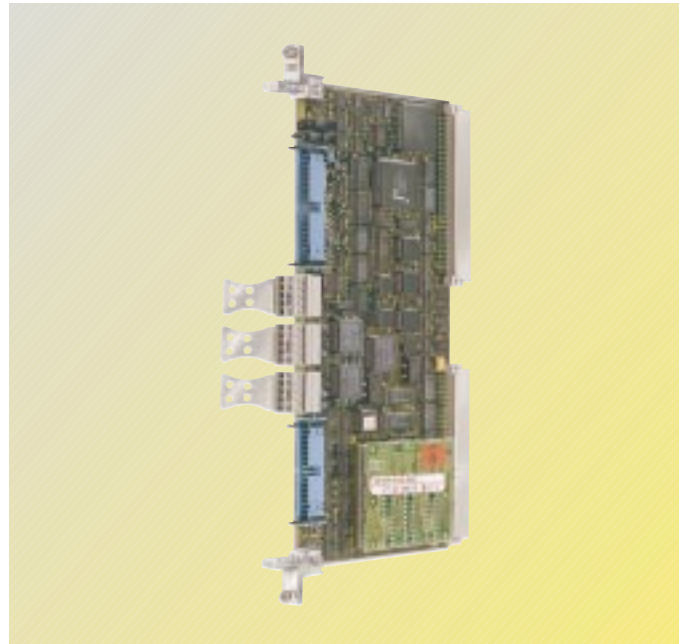
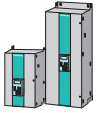

Fig. 4/19
T300 board with memory submodule

4

Selection and ordering data

Description	Order No.:	Weight (approx.) kg	Dimensions W x H x D mm
T300 Technology board T300, as a hardware package (T300 with 2 connecting cables SC58 and SC60, terminal strip SE300 and hardware operating instructions in English/German). For further details, integration of the T300 board and accessories, see Catalog DA 65.10 SIMOVERT MASTERDRIVES Vector Control. Supplied unassembled and not configured.	6SE7090-0XX87-4AH0	2	300 x 400 x 300
T300 technology board as spare part	6SE7090-0XX84-0AH2		



SIMOREG 6RA70 DC MASTER

Options

Communication

Overview

One of the most important advantages of the SIMOREG 6RA70 is that it is equipped with serial interfaces and another is that

the SIMOREG converters can be easily integrated into the world of automation. This also applies to the AC drive product range

from Siemens that utilizes many identical communication boards, simplifying implementation and reducing your

spare parts inventories on site.

Optimized integration of the drives in the world of automation

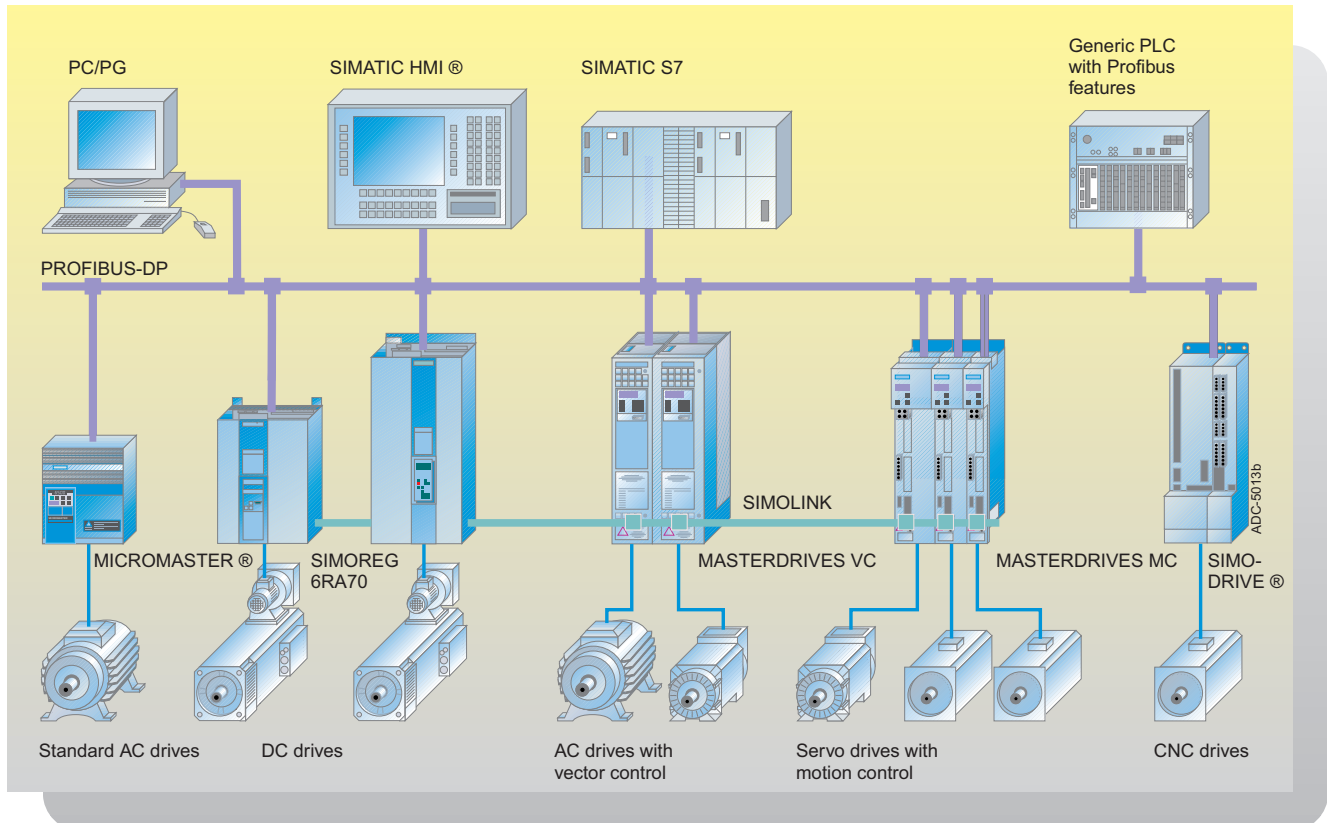

Fig. 4/20

The addition of easily installed communication boards allows a wide range of communications possibilities to be configured. The SIMOREG 6RA70 is therefore able to communicate using many different protocols.

- SIMOLINK fiber-optic network with peer-to-peer functionality for extremely high-speed data exchange (11 Mbaud)
- PROFIBUS-DP communication
- Communication by means of CAN protocol
- DeviceNet communication

All SIMOREG 6RA70 converters are equipped with two serial interfaces as standard that are not only USS-capable but which also feature peer-to-peer functionality for baudrates of up to 187.5 Kbaud. There is a choice of RS 232 and RS 485 transfer format for the first serial interface.

The interface is located on the front of the unit and an OP1S or PC (with DriveMonitor or Drive ES) can be easily connected to it. The second interface is a dedicated RS 485 interface that is located on the terminal strip of the CUD1.

An additional RS 485 interface is available on the optional terminal expansion board CUD2.

The USS protocol is a proprietary Siemens protocol for drive systems. It enables up to 31 stations to be connected via the bus on the basis of RS 485 transmission. The data are exchanged in accordance with the host/slave access mechanism. The host can be a higher-level system such as a SIMATIC S5 or S7, a PC or a non-Siemens automation system.

SIMOREG 6RA70 DC MASTER

Options

Communication



SIMOLINK communication board SLB

The SLB optional board (**SIMOLINK Board**) acts as the interface between SIMOREG drives and the SIMOLINK system.

The SLB is mounted on the ADB adapter board. An LBA bus adapter is needed for this purpose.

Every SLB optional board is a node in the SIMOLINK system. The maximum number of nodes is restricted to 201.

The SIMOLINK drive interface is used to exchange data rapidly between different drives and to synchronize them with a common system clock cycle. SIMOLINK is a closed circuit into which all nodes are connected.

Data are exchanged between the individual nodes by way of fiber-optic cables. Optical fibers made of glass or plastic can be used as transmission lines.

The SLB optional board has a 24 V voltage input for connecting an external voltage supply. This ensures that data can still be exchanged within the SIMOLINK circuit when the converter is switched off.

The board features three LEDs for displaying the current operational status.

Operating principle

The SLB optional board acts as the interface between the SIMOLINK system and converters and/or inverters. It can operate as either a SIMOLINK Dispatcher or a SIMOLINK Transceiver. Its functionality is selected by means of parameter settings.

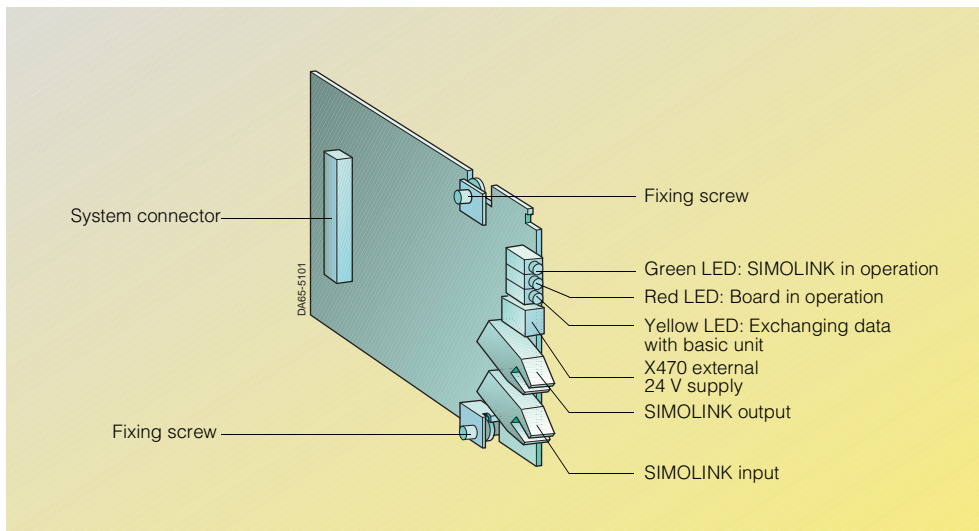

Fig. 4/21
SIMOLINK communication board SLB

Designation	Value
Size (length x width)	90 mm x 83 mm
External voltage supply	24 V DC
Power consumption from external voltage supply	Max. 200 mA
Voltage supply from basic unit	5 V DC
Power consumption from basic unit voltage supply	Max. 600 mA
Switchover of voltage source	Automatic, external has priority
Station address	Parameter Pxxx Pxxx = 0: Dispatcher function Pxxx ≠ 0: Transceiver function
Data transfer rate	11 Mbaud
Propagation delay	Max. 3 clock cycles
Fiber optic cable	Plastic or glass fibers
Cable length	<ul style="list-style-type: none"> • Max. 40 m between 2 stations (plastic) • 300 m between 2 stations (glass)
Reduction of transmitter power (values for plastic fiber optic cables)	Parameter Pxxx Pxxx = y: 40 m Pxxx = y: 25 m Pxxx = y: 10 m
Display	3 LEDs <ul style="list-style-type: none"> • Green: SIMOLINK • Red: Optional board • Yellow: Interface to basic unit

Voltage supply

The optional board can be supplied with the necessary operating voltage, both internally from the SIMOREG converter and from an external source. The external power source has priority. Switchover between the sources takes place automatically on the board.

Note

The external voltage supply must not be switched over while the bus is operating. When the supply is switched over automatically, a reset signal is generated on the board which would otherwise cause some message frames to be lost.

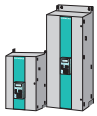

SIMOLINK communication board SLB

Features

- The transfer medium is a fiber-optic conductor. Either glass or plastic optical fibers can be used.
- The structure of the SIMOLINK is an optical fiber ring, whereby every station in the ring acts as a signal amplifier.
- The following distances are possible depending on the selected medium:
 - Max. 40 m between each station with plastic optical fibers or
 - Max. 300 m between each station with glass optical fibers.
- Up to 201 stations can be interconnected on SIMOLINK.
- Extremely fast (11 Mbits/s; 100 32-bit data elements in 0.63 ms).
- No dial, i.e. every SIMOREG 6RA70 unit can send or receive process data to or from every other SIMOREG 6RA70 unit.

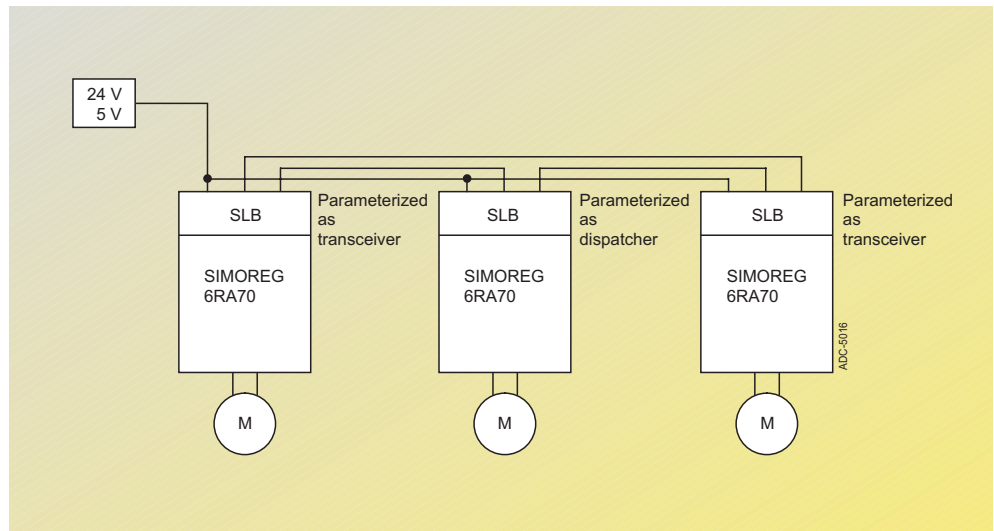

Fig. 4/22
Peer-to-peer functionality with SIMOLINK

Selection and ordering data

Description	Order No.:
SIMOLINK SLB communication board	6SX7010-0FJ00 1)
Plastic fiber-optic cable 100 m, 20 X470 connectors, 40 FOC connectors	6SX7010-0FJ50
Plastic fiber-optic cable , 1 X470 connector, 2 FOC connectors	6SY7000-0AD15

1) Including 5 m plastic fiber-optic cable and connector

SIMOREG 6RA70 DC MASTER

Options

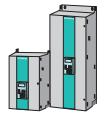

Communication

PROFIBUS-DP communication board CBP2

The optional CBP2 (**C**ommunication **B**oard **P**ROFIBUS) is used to link drives to higher-level automation systems via PROFIBUS-DP.

The CBP2 is mounted in the ADB adapter board for installation in the converter. An LBA bus adapter is needed for this purpose.

The optional board features three LEDs (green, yellow, red) for displaying the current operational status.

The board is supplied with power via the basic unit.

Baudrates of 9.6 Kbits/s to 12 Mbits/s are possible.

Data exchange via PROFIBUS-DP

The bus system allows data to be exchanged very rapidly between the drives and higher-level systems (e.g. SIMATIC). The drives are accessed in the bus system according to the master/slave principle. The drives are always slaves. Each slave is uniquely identified by a slave address.

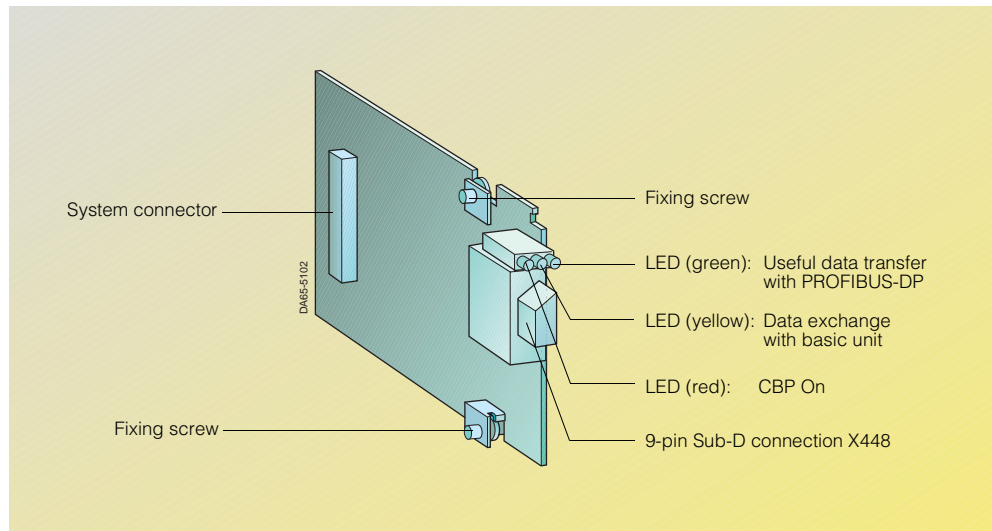

Fig. 4/23
Communication board CBP2

4

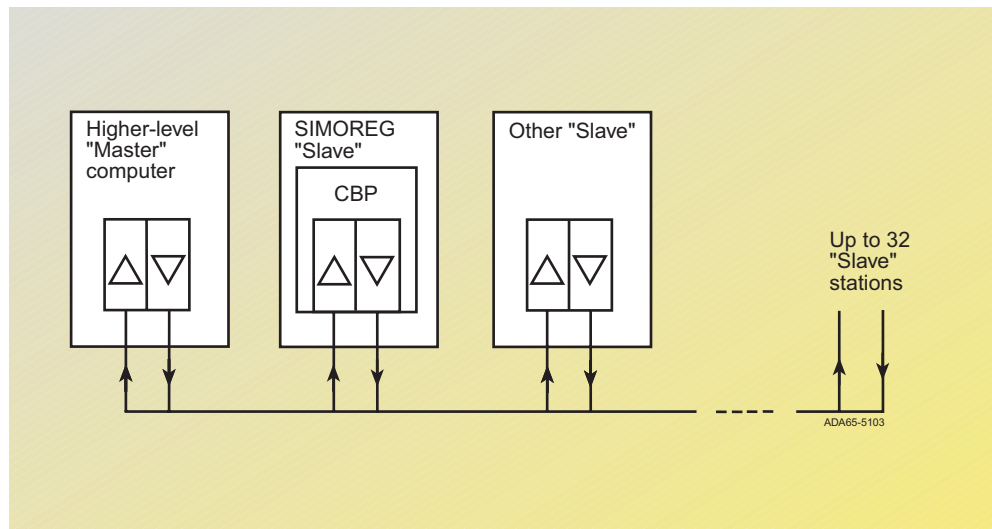
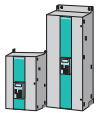

Fig. 4/24
PROFIBUS-DP connections



PROFIBUS-DP communication board CBP2

PROFIBUS-DP message frame

Data are exchanged in message frames. Each message frame contains useful data which are divided into two groups:

- Parameters (parameter ID value, PKW)
- Process data (PZD)

The PKW area contains all transfer data which are needed to read or write parameter values or read parameter properties.

The PZD area contains all the information needed to control a variable-speed drive. Control information (control words) and setpoints are passed to the slaves by the PROFIBUS-DP master. Information about the status of slaves (status words) as well as actual values are transferred in the opposite direction.

The length of the PKW and PZD components in the message frame as well as the baudrate, are determined by the master. Only the bus address and, if necessary, the message frame failure time are set on the slaves.

Connections

The optional CBP2 board features a 9-pin Sub D connector (X448) for connection to the PROFIBUS-DP system. The connections are short-circuit proof and floating.

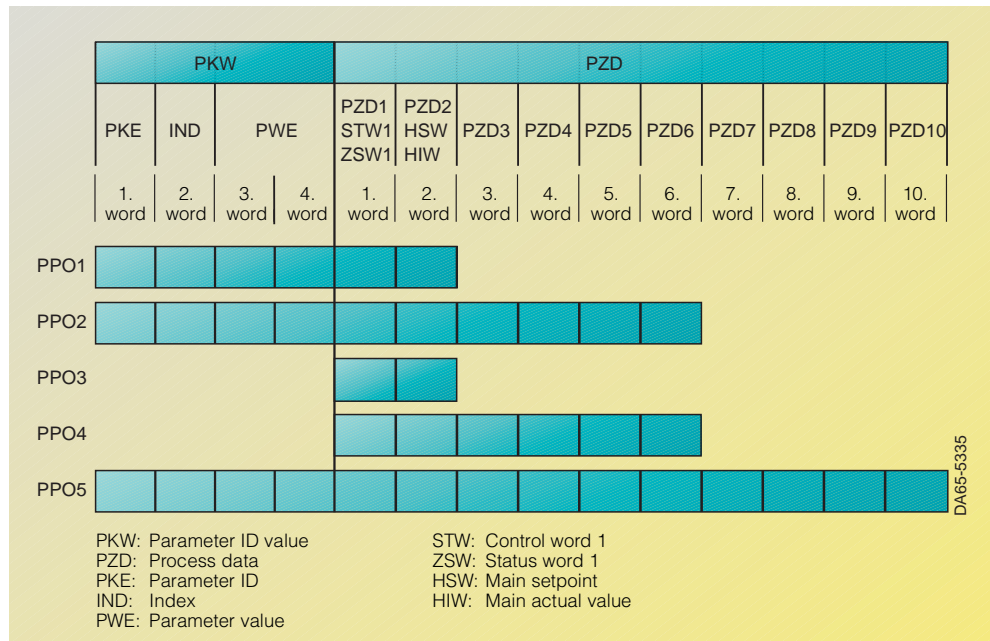

Fig. 4/25 Useful data transfer according to "PROFIBUS profile for variable-speed drives PROFIDRIVE"

Pin assignments on X488 connector

Pin	Designation	Meaning
1	SHIELD	Ground connection
2	-	Not assigned
3	RxD/TxD-P	Receive/Send data P (B/B')
4	CNTR-P	Control signal
5	DGND	PROFIBUS-DP data reference potential (C/C')
6	VP	Supply voltage +
7	-	Not assigned
8	RxD/TxD-N	Receive/Send data N (A/A')
9	-	Not assigned

Selection and ordering data

Description	Order No.:
CBP2 Communication board (PROFIBUS-DP/12 m baud)	6SX7010-0FF05
PROFIBUS-DP cable (per meter; min. 20 m/max. 100 m)	6XV1830-0AH10
PROFIBUS-DP connector plug	6ES7972-0BB40-0XA0

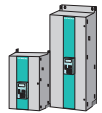

Communication

CAN communication board CBC

The CAN protocol (**C**ontroller **A**rea **N**etwork) is specified in the proposed international standard ISO DIS 11 898 whereby only the electrical parts of the Physical Layer and the Data Link Layer (Layers 1 and 2 in the ISO/OSI Layer reference model). The CiA (**CAN in Automation**, an international user's and manufacturer's association) has defined implementation as an industrial fieldbus with the DS 102-1 recommendations for bus coupling and the bus medium.

- The CBC board complied with the definitions in ISO-DIS 11 898 and in DS 102-1.
- The CBC board only supports CAN Layers 1 and 2. Higher-level additional communication definitions of the various user organizations, such as CAN open of the CiA are *not* currently supported (CAN open on request).

The CBC (Communication Board CAN) facilitates communication between SIMOREG converters and a higher-level automation system, between SIMOREG converters and between SIMOREG converters and other field devices by means of the CAN protocol. The board is supplied with power via the basic unit.

The CBC board is limited to the main specifications of CAN and is therefore free of the dependent specifications of the user organizations. Data is exchanged with SIMOREG in accordance with the useful data definition for drive technology with PROFIBUS-DP:

- Process data (control words, setpoints, status words and actual values)
- Parameter area (mechanism for reading and writing parameter values, e.g. setting values, warnings, fault numbers or fault values)

The useful data are transferred in the form of communication objects (identifiers).

Individual communication objects are defined for the process data to and from the drive as well as for the "write" and "read" parameter tasks.

Functional scope		
Process data	Max. 16 words	
Data transfer rate	10, 20, 50 Kbits/s	Cable length up to 1000 m
	100 Kbits/s	Cable length up to 750 m
	125 Kbits/s	Cable length 530 m
	250 Kbits/s	Cable length 270 m
	500 Kbits/s	Cable length 100 m
1 Mbits/s	Cable length 9 m	
Max. number of bus nodes	≤ 124	

Data exchange with CAN

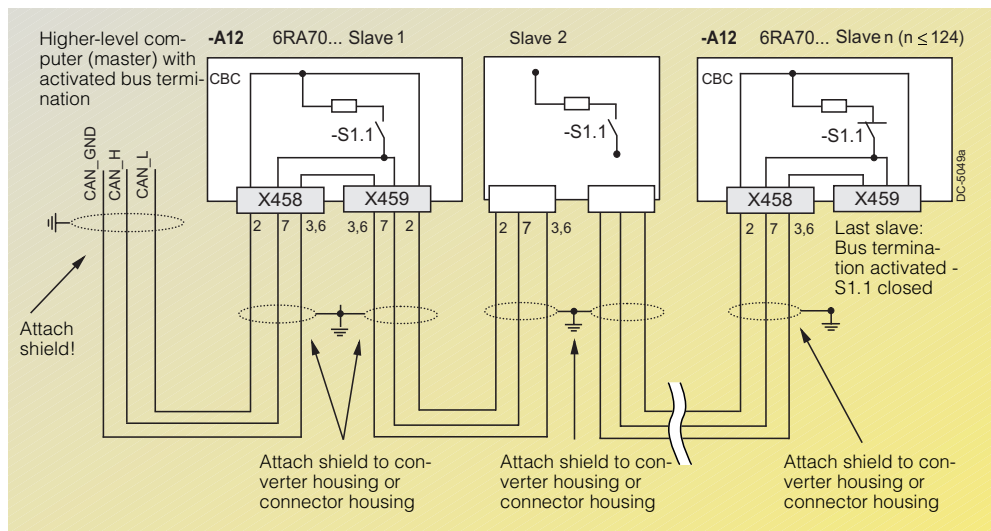

Fig. 4/26 Data exchange between CBC boards with bus interruption

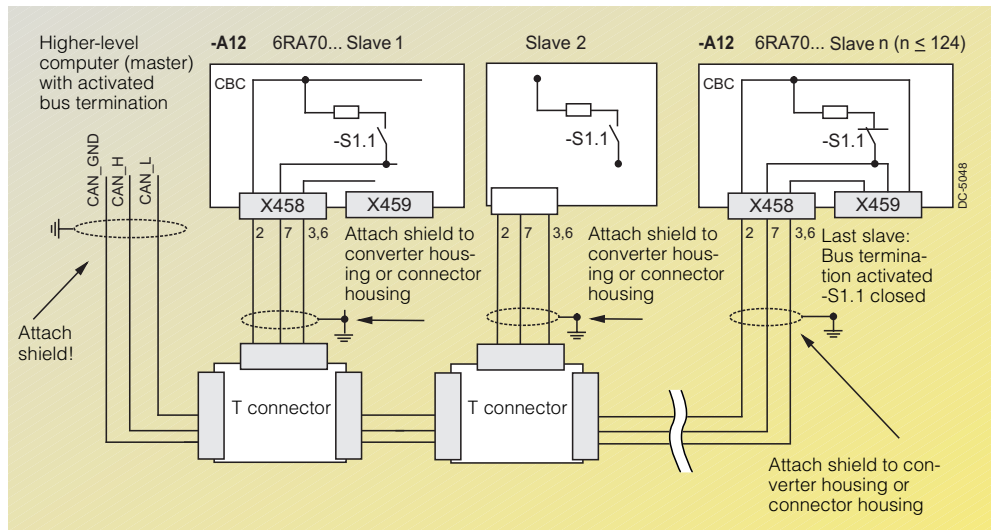
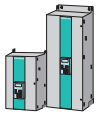

Fig. 4/27 Data exchange between CBC boards without bus interruption



CAN communication board CBC

The CAN protocol supports high-speed data transfer between bus stations. In the case of useful data transfer, a distinction is made between the parameter ID value (PKW) and the process data (PZD).

A CAN data message frame comprises the protocol header, the CAN identifier (up to 8 bytes of useful data) and the protocol trailer. The CAN identifier serves to uniquely identify the data message frame. In Standard Message Format, up to 2048 different CAN identifiers are possible; in Extended Message Format, 2^{29} CAN identifiers are possible. Extended Message Format is tolerated by the CBC board but not evaluated. The CAN identifier specifies the priority of the data message frame. The lower the number of the CAN identifier, the higher the priority of the message frame.

Up to 8 bytes of useful data can be transferred in a CAN data message frame. The PKW area always comprises 4 words or 8 bytes

i.e. the data can be transferred in a single data message frame. In the case of SIMOREG 6RA70, for example, the

process data area comprises 16 words, so 4 data message frames are required in total to transfer all the process data.

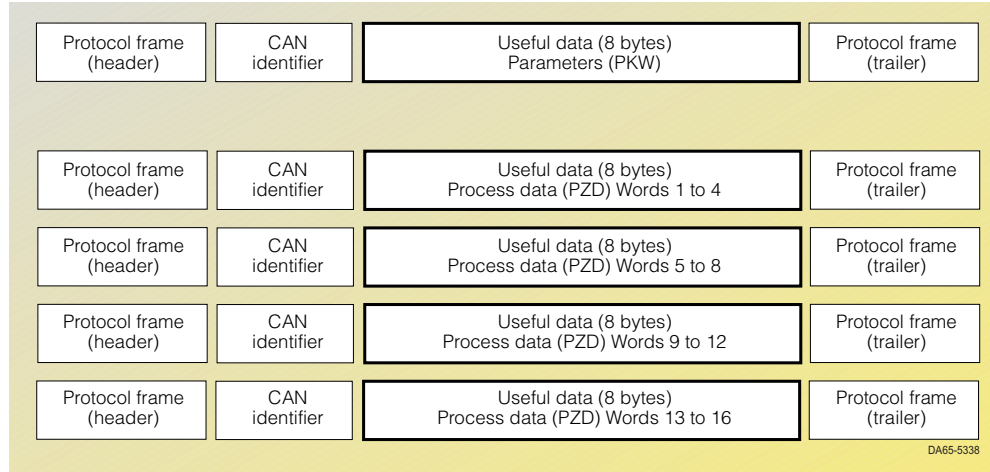

Fig. 4/28
Structure of the useful data in the message frame

X458 and X459 connectors on the CBC board

The CBC communication board has one 9-pin Sub-D plug (X458) and one 9-pin Sub-D socket (X459) for connection to CAN.

The pin assignments and internal connections of the connectors are identical. The connector interface is short-circuit proof and floating.

Fitting the CBC board

One LBA and one ADB are needed for installing the board.

Pin	Designation	Meaning
1	–	Not assigned
2	CAN_L	CAN_L bus line
3	CAN_GND	CAN ground (M5 ground)
4	–	Not assigned
5	–	Not assigned
6	CAN_GND	CAN ground (M5 ground)
7	CAN_H	CAN_H bus line
8	–	Not assigned
9	–	Not assigned

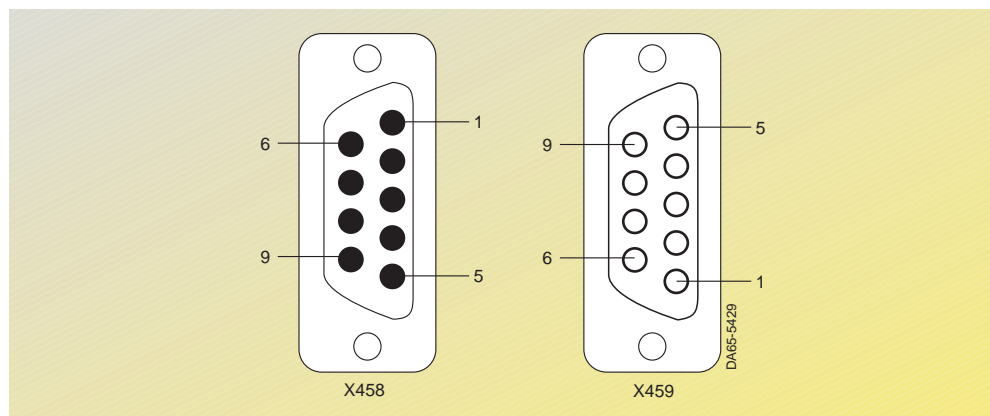

Fig. 4/29
X458 (plug) and X459 (socket) connections

Selection and ordering data

Description	Order No.:
CBC communication board (CAN bus)	6SX7010-0FG00



Communication

Communication board CBD DeviceNet

The CBD (**C**ommunication **B**oard **D**eviceNet) facilitates communication between SIMOREG converters and higher-level programmable controllers or other field devices by means of the DeviceNet protocol. The CBD board is inserted in the electronics box of the SIMOREG 6RA70 unit using the LBA and ADB adapter boards.

The CBD board supports the transfer of process data and parameter data using "DeviceNet Explicit Messages" and "DeviceNet I/O Messages".

With DeviceNet, Explicit Message Connections provide generic, multi-use communication paths between two units. This allows typical requirements-oriented or response-oriented functions (e.g. board configuration) to be implemented.

In contrast, DeviceNet I/O Message Connections provide communication paths for special purposes between the transmitting and receiving units. Application-specific I/O data are transferred via an I/O connection. The significance of the data within an "I/O message" is determined by the associated "Connection ID".

The DeviceNet alarms can be subdivided into three main groups:

- DeviceNet configuration data, e.g. channel assignment, timeouts and I/O configurations, whereby "Explicit messages" are used
- Process data, e.g. control words, setpoint/reference values, status information and actual values, whereby "I/O messages" are used
- Parameter data for reading/writing drive parameter data, whereby manufacturer-specific PKW objects and "Explicit messages" are used.

The drive is controlled by process data (e.g. activation/deactivation and setpoint input). The number of process data words (4, 8 or 16) is either determined on switch-on by the value of certain CB parameters or dynamically by DeviceNet. The purpose for which the individual process data words are used is determined in the drive and differs in accordance with the actual function of each individual drive. The process data are processed with the highest priority and shortest time segments.

The master uses the manufacturer-specific PKW object for the purpose of reading drive parameters with DeviceNet or modifying them, whereby the Explicit Messaging Channel is used. The user therefore has access to all parameters in the basic unit (CU) and any existing technology board (TB) via DeviceNet. Examples for this include read-out of detailed diagnostic information, error messages, etc. In this manner, additional information for drive monitoring could be requested from a higher-level system (e.g. a PC) without affecting the transmission of process data.

Control and operation of SIMOREG 6RA70 converters over DeviceNet

In the process data area, all the information is transferred that is necessary for controlling a drive within a specific technical process. The control information (control words) and setpoints are sent to the drive from the DeviceNet master. Information about the status of the drive (status words) as well as actual values are transferred in the opposite direction.

The CBD communication board saves the received process data in the Dual-Port RAM in the order in which they were transferred in the message frame. An address is assigned to each word in the Dual-Port RAM. The content of the Dual-Port RAM in the drive (CU and, if necessary, TB) can be freely assigned by setting parameters. It can, for example, be specified that the second word in the process data area of the message frame should be used as a speed setpoint for the ramp-function generator follow-up. The same mechanism also applies for other setpoints and for each individual control word bit. This mechanism also applies for data exchange in the opposite direction when actual values and status words are transferred to the master. Diagnostic LEDs provide the user with information quickly about the current status of the CBD. More detailed diagnostic information can be read directly out of the diagnostics memory of the CBD with the help of a diagnostic parameter.

The CBD board operates with the "Predefined master/slave connection set", that is defined in the DeviceNet specification. Both "Poll" and "Bit strobe" I/O messages are supported.

The CBD complies with the "DeviceNet Device Profile for Communication Adapters" (Device Type 12). This profile was selected to ensure that all features and extended functions of the SIMOREG 6RA70 converter can be used by the DeviceNet master. For the same reason, the CBD board has not implemented the "DeviceNet DC Drives" profile.

Data rate	Cable length	Dropcable length max.	Cumulative
125 KB	500 m	6 m	156 m
250 KB	250 m	6 m	78 m
500 KB	100 m	6 m	39 m

Selection and ordering data

Description	Supplied unassembled Order No.:
CBD DeviceNet communication board	6SX7010-0FK00
Operating instructions	Supplied with the board

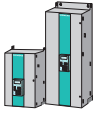

SCB1 interface board

The SCB1 (Serial Communication Board 1) has one fiber-optic connection and can be used to establish:

- A peer-to-peer connection between several devices with a max. transfer rate of 38.4 kbits/s
- A serial I/O system (see Figure 4/30) in conjunction with the serial interface boards SCI1 and SCI2 (see Page 4/15).

This can be implemented to

1. Expand the binary and analog inputs and outputs of the basic units
2. Assign the terminals of the inputs and outputs customer-specifically (e. g. NAMUR).

The following board combinations are possible:

- SCB1 with one SCI1 or SCI2 each
- SCB1 with two SCI1s or SCI2s each
- SCB1 with one SCI1 and SCI2 each

The SCB1 interface board is plugged into location 2 or 3 of the electronics box (see the description on Page 4/6).

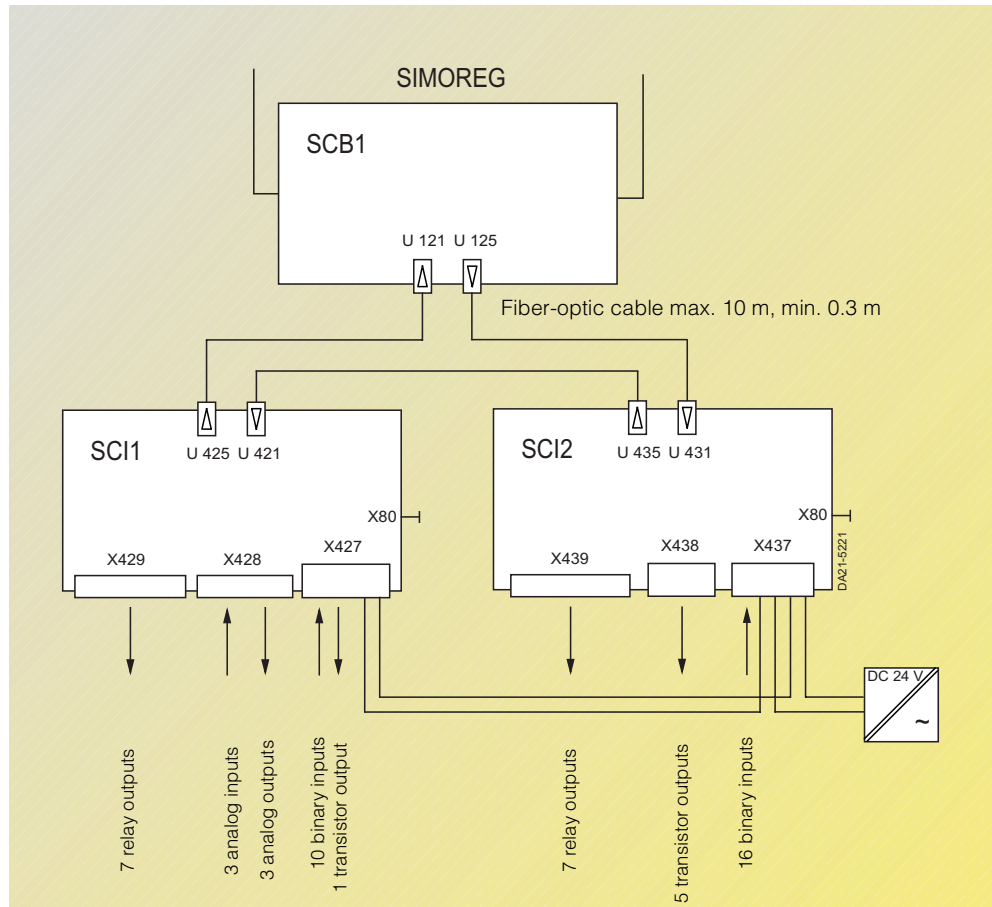
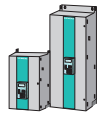

Fig. 4/30
Example to show connection of a serial I/O system comprising an SCB1, SCI1

Selection and ordering data

Description	Order No.:	Weight (approx.) kg	Dimensions W x H x D mm x mm x mm
SCB1 Interface board with fiber-optic cable connection supplied unassembled incl. 10 m FO cable	6SE7090-0XX84-0BC0	0.5	25 x 235 x 125



Operating and monitoring

OP1S operator panel

The OP1S (**O**perator **P**anel) is an optional input/output unit that can be used to parameterize the converters. Parameterization is menu driven; the parameter number is selected and the parameter value is entered. The displays are in plain text.

The descriptions of the parameters and parameter values as well as the text displays are included in English, German, French, Spanish and Italian as standard.

The OP1S is equipped with non-volatile memory and is able to save complete parameter sets permanently. It can therefore be used to archive parameter settings and to transfer parameter sets from one unit to another. The memory capacity is sufficient to store, for example, 5 data sets from CUMC boards. It is not possible to save data sets from technology boards (e.g. T100, T300).

There is a 9-pin Sub-D connector on the rear of the OP1S. This is used for connection of the power supply as well as for communication with the connected units.

The OP1S operator panel is directly plugged into the Sub-D socket of the PMU operator control and parameterization panel and screwed into the front cover. The OP1S operator panel can also be used as a remote operation device. The cable between the PMU and the OP1S can be up to 200 m in length. In the case of distances greater than 5 m, a generally available 5 V power supply unit with a current of at least 400 mA (Fig. 4/33) must be connected at the OP1S end.

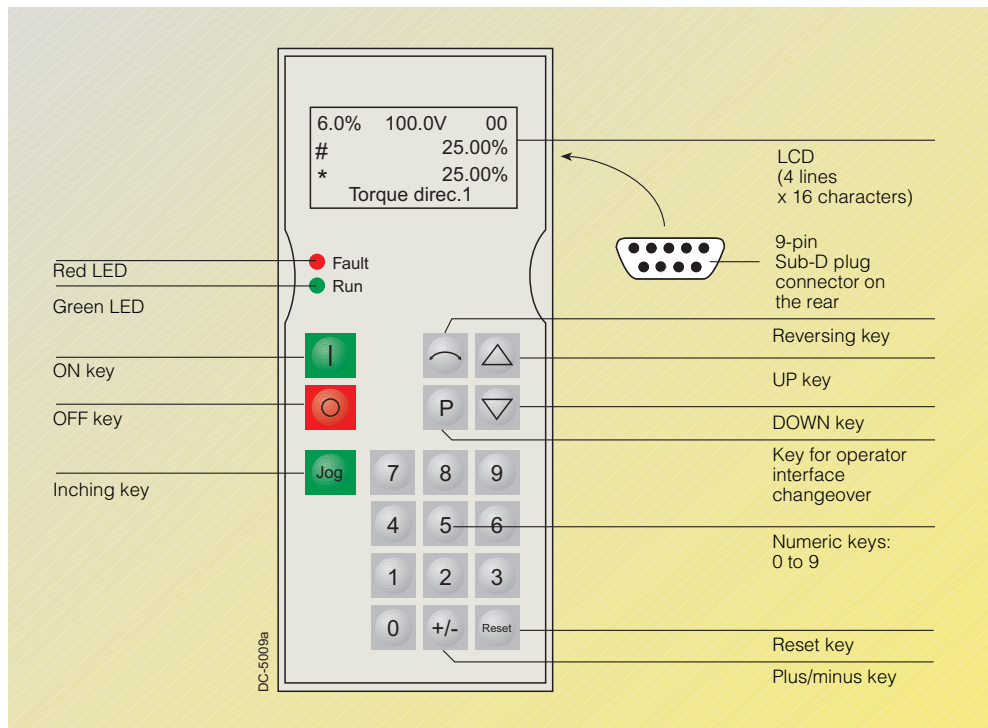

Fig. 4/31
View of the OP1S

OP1S connections with RS 485

Pin	Designation	Meaning
1	-	-
2	-	-
3	RS 485 P	Data via RS 485 interface
4	-	-
5	N5V	Ground
6	P5V	5 V auxiliary voltage supply
7	-	-
8	PS485 N	Data via RS 485 interface
9	-	Reference potential

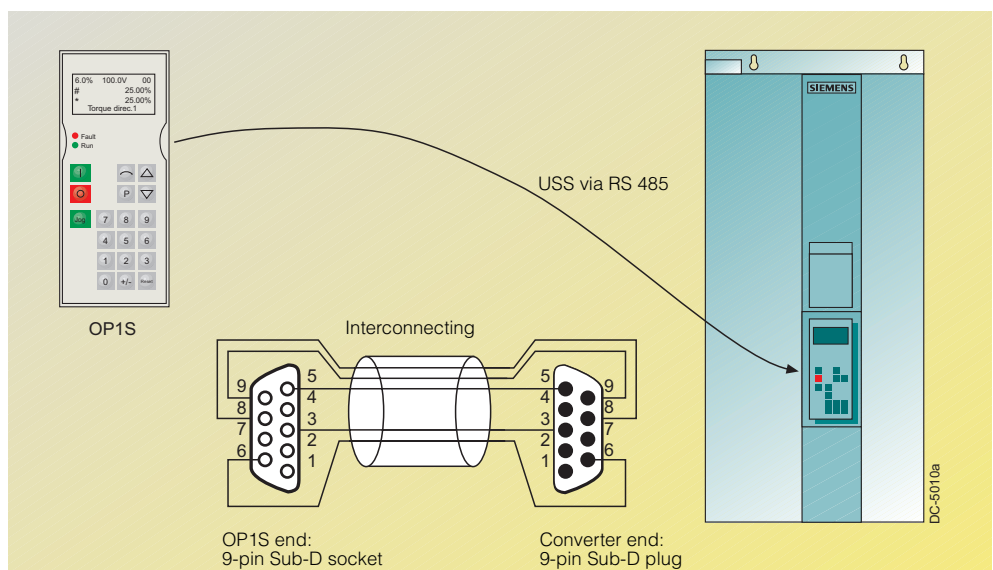
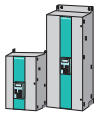

Fig. 4/32
OP1S with point-to-point link



OP1S operator panel

The communication between the OP1S and the converter to be operated takes place via a serial interface (RS 485) with USS protocol (see Figure 4/31). In this communication, the OP1S assumes the role of the master. The connected converters operate as slaves. The OP1S can be operated at transmission rates of 9.6 kbits/s and 19.2 kbits/s.

It can communicate with up to 31 slaves (addresses 1 to 31). It can therefore be used either with a point-to-point connection (for operating one converter) or in a bus configuration (for operating several converters).

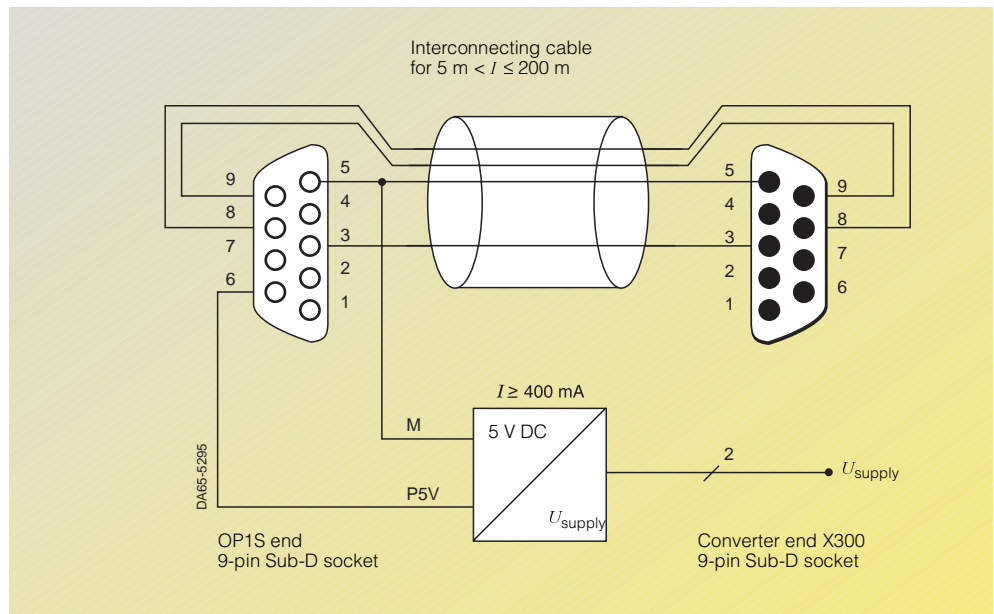

Fig. 4/33
OP1S with point-to-point connection, up to 200 m cable length

Selection and ordering data

Description	Order No.:
OP1S operator panel	6SE7090-0XX84-2FK0
Adapter AOP1S for cabinet door mounting including 5 m connecting cable	6SX7010-0AA00
Connecting cable PMU OP1S, 3 m	6SX7010-0AB63
Connecting cable PMU OP1S, 5 m	6SX7010-0AB05

SIMOREG 6RA70 DC MASTER

Options

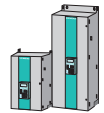

Operating and monitoring

DriveMonitor ¹⁾

Features

The current version of the DriveMonitor is part of the standard scope of supply on CD-ROM.

- All basic unit parameters can be set and monitored by means of tables that can be created as required
- Reading, writing, printing and comparison of parameter sets
- Process data operation (control signals, setpoints)
- Diagnosis (fault, warning, fault memory)
- Offline and online operation.
- Parameterization of technology boards T100, T300 and T400
- Graphical presentation of the trace memory function for analysis
- Guided graphical parameterization during start-up.

System requirements

- Win 95/98/Me/NT/2000
- 64 MB RAM
- Spare hard-disk storage 10 Mbytes
- Screen resolution 800 x 600 or higher.
- Interfacing via USS
- Serial interface RS 232 (for one converter, point-to-point)
- RS 485 serial interface (for several converters and bus operation), e.g. with RS 232/RS 485 interface converter SU1.

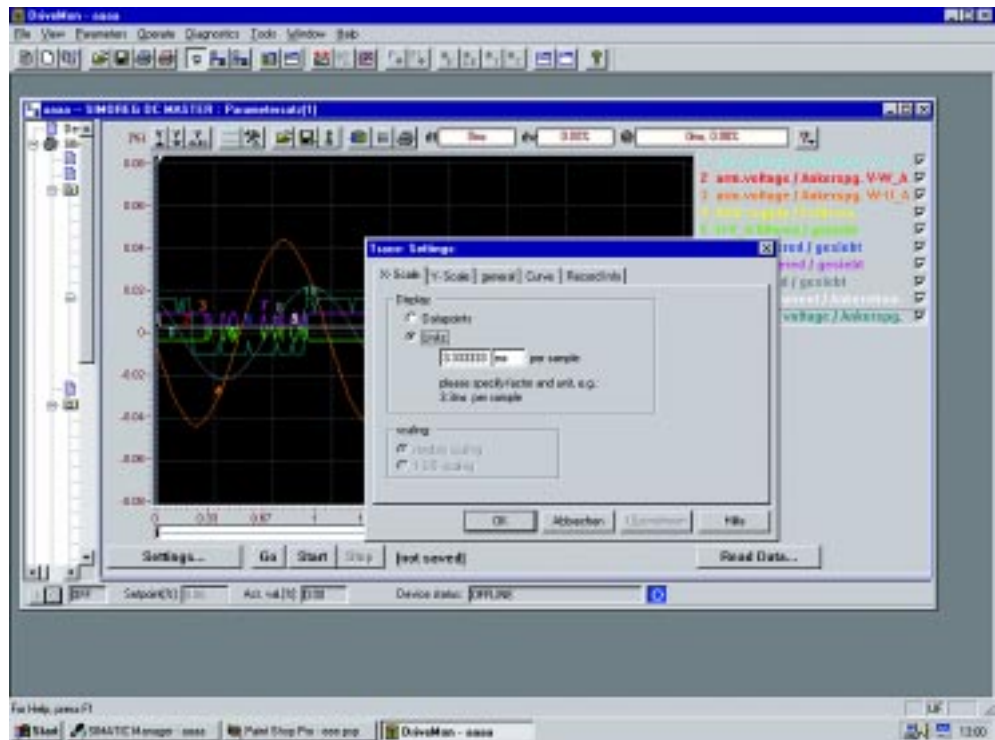

Fig. 4/34
DriveMonitor: Trace function for converter diagnosis

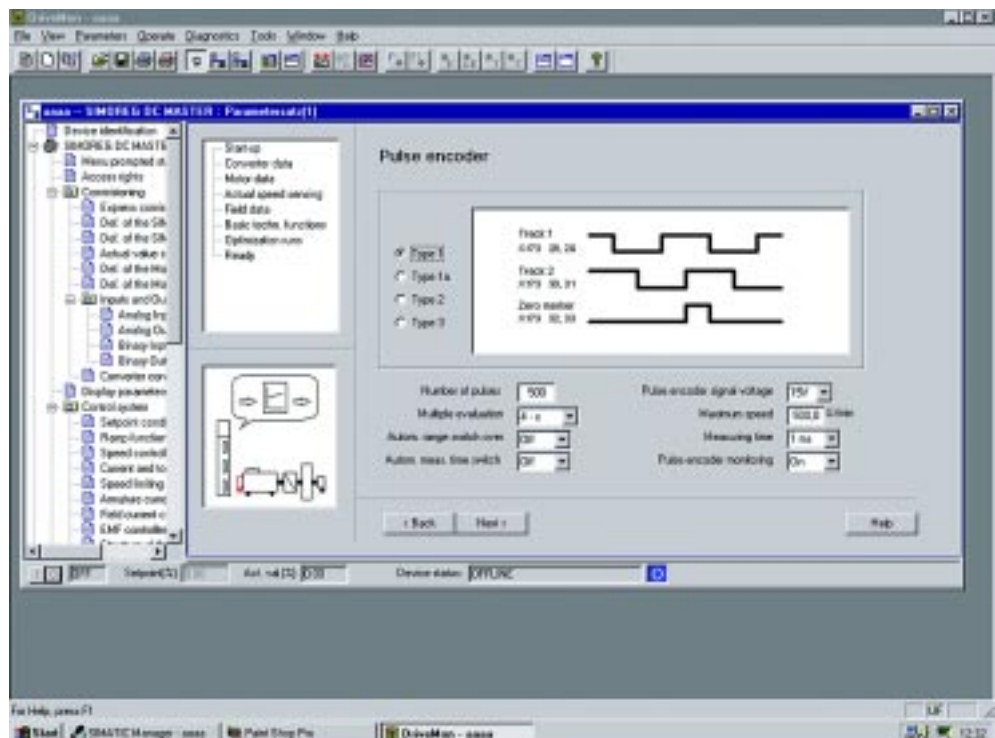
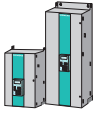

Fig. 4/35
DriveMonitor: Guided start-up

1) The DriveMonitor supersedes SIMOVIS



Drive ES engineering package

With Drive ES (Drive Engineering System), drives from the SIMOREG range can be totally integrated into the SIMATIC automation world with regard to communication, configuration and data management.

Drive ES comprises four software packages that can be ordered separately: Drive ES Basic, Drive ES Graphic, Drive ES SIMATIC and Drive ES PCS7.

- Drive ES Basic is the basic software that is used to parameterize all drives online and offline as well being the prerequisite for the Drive ES Graphic software.
- Drive ES Graphic is the software that is used for graphical online and offline configuration of the BICO function blocks. The prerequisites are an installed version of Drive ES Basic and an installed version of SIMATIC CFC \geq V 5.1 (graphical programming tool, see Catalog ST 70, "Industrial Software").
- Drive ES SIMATIC requires an installed version of STEP 7. It contains a SIMATIC function block library and therefore supports easy and reliable programming of the PROFIBUS-DP interface in the SIMATIC CPU for the drives.
- Drive ES PCS7 requires prior installation of SIMATIC PCS7, Version V 5.0 upwards. Drive ES PCS7 provides a function block library complete with function blocks for the drives and the associated faceplates for the operator station. This enables operation of the drives from the PCS7 process control system.

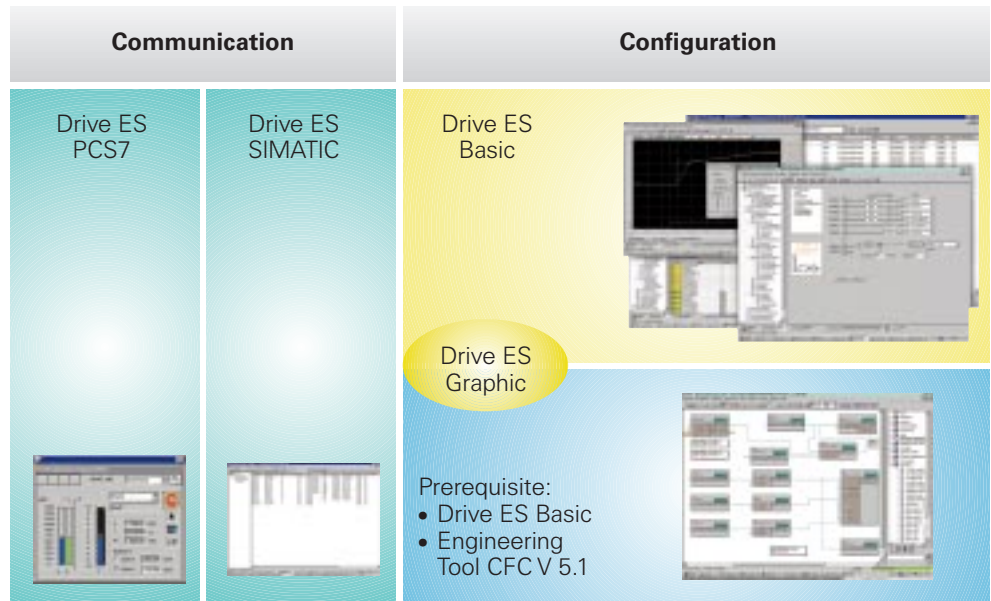

Fig. 4/36 Structure of the Drive ES product

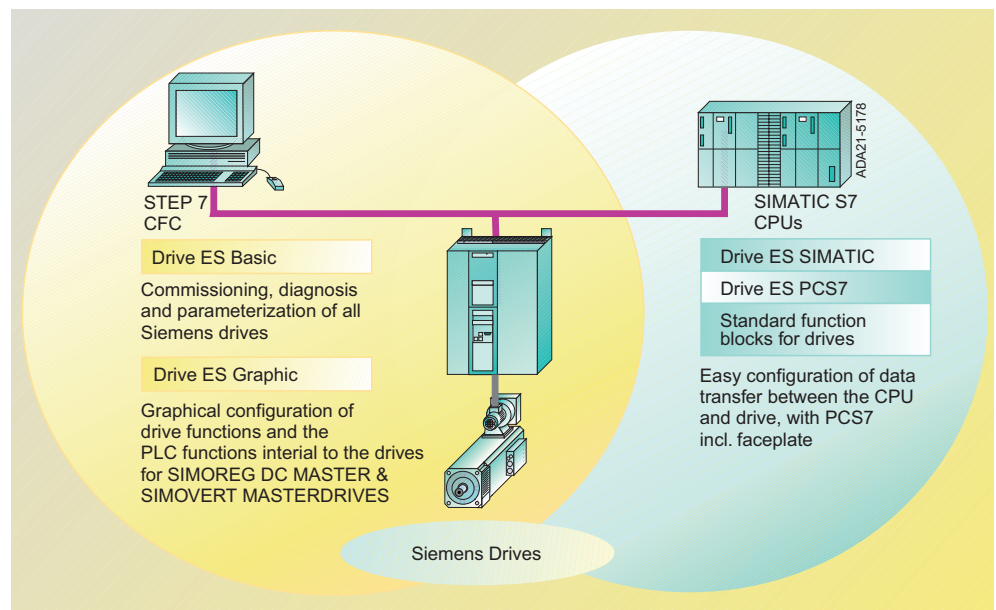

Fig. 4/37 Task distribution for the Drive ES packages

SIMOREG 6RA70 DC MASTER

Options



Operating and monitoring

Drive ES Basic

- Drive ES is based on the SIMATIC Manager user interface.
- The parameters and diagrams of drives are available in SIMATIC Manager (integrated data management).
- Drive ES ensures that parameters and diagrams are uniquely assigned to a drive.
- A SIMATIC project complete with drive data can be archived.

- SIMATIC Teleservice (V5) can be used.
- It communicates with the drive over PROFIBUS-DP or USS.

Functions

- Trace evaluation for SIMOREG DC MASTER.
- Read out fault memory for SIMOREG DC MASTER.

- Upload and download of parameter sets (as a complete file or as a delta file compared to the factory settings).
- Parameter sets can be freely combined and processed.
- Script files can be used.
- Guided start-up for SIMOREG DC MASTER.

Installation with STEP 7

Drive ES Basic can be installed as an option for STEP 7 (V ≥ 5.0) and integrates itself homogeneously in the SIMATIC environment.

Installation without STEP 7

Drive ES Basic can also be installed without STEP 7 and uses its own Drive Manager (similar to the SIMATIC Manager).

Drive ES Graphic

- Function diagrams are stored in SIMATIC CFC format drive-oriented.
- The drive functions are configured in BICO technology with SIMATIC CFC.
- Offline functionality.
- Test mode (online functionality) complete with "Modify connection", "Modify value" and "Activate function block".

- Read out and feedback documentation.

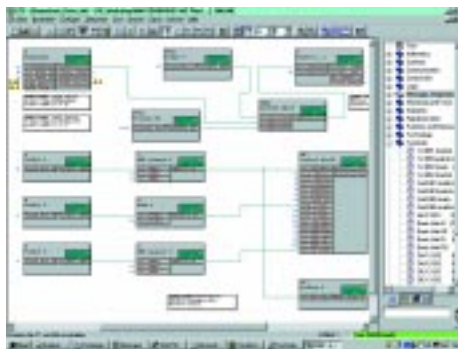

Fig. 4/38
Graphical programming with Drive ES Graphic and CFC

Drive ES SIMATIC

- This provides SIMATIC CPU function blocks and sample projects that process the communication with Siemens drives over PROFIBUS-DP or USS.
- The communication functions are parameterized and not programmed.

Features

- Function blocks in STEP 7 design; symbolic addressing; function blocks with instance data; online help.
- For use in all SIMATIC programming and configuration environments, such as LAD, FDB, STL, SCL and CFC.

- New function block structure: Individual modular functions for runtime-optimized program generation.

Function block types

- Read and write process data of freely configurable length and consistency.
- Exchange parameters cyclically and non-cyclically, monitor communication, read out fault memory from SIMOREG DC MASTER.
- Download parameters into the drive via the CPU.

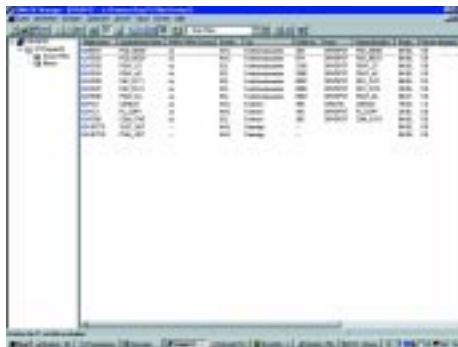

Fig. 4/39
Integrating drives into the STEP 7 Manager

Drive ES PCS7

- Integrates drives with a PROFIBUS-DP interface into PCS7.
- Can be used with STEP 7 or PCS7 V 5 upwards.

Function block types

- Display blocks and control blocks for the integration of drives into PCS7.

Note

Function blocks will be available for the SIMOREG DC MASTER from August 2001.

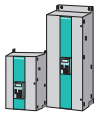

SIMOREG 6RA70 DC MASTER

Options

Operating and monitoring

Integration of drives into SIMATIC S7 with Drive ES

Drive ES Basic supports the user with commissioning, servicing and diagnosing all Siemens drives. It can be integrated as an option into STEP 7 or it can be installed without STEP 7 as a stand-alone tool on a PC or programming device. In the case of stand-alone installation, the Drive Manager of Drive ES Basic will be installed instead of the SIMATIC Managers with the same Look & Feel. When it is integrated as an option for STEP 7, the Version of STEP 7 must correspond to that listed in the ordering data.

Drive ES Graphic is an option for Drive ES Basic and is used in conjunction with the SIMATIC tool CFC (Continuous Function Chart) for graphical configuration of the functions available with the SIMOREG DC MASTER (basic unit functions, process-specific functions and freely-definable function blocks). Pre-condition: Drive ES Basic V 5 and CFC V 5.1 upwards must have been installed on the computer beforehand.

Drive ES SIMATIC provides function block libraries complete with SIMATIC function blocks which reduces the configuration of the communication functions between SIMATIC S7 CPUs and Siemens drives (e.g. SIMOREG DC MASTER) to simple parameter settings. Drive ES SIMATIC supersedes the DVA_S7 software package for all versions of STEP 7 \geq V 5.0 and can also be installed and implemented stand-alone, i.e. without Drive ES Basic.

Drive ES PCS7 provides a function block library complete with display and control function blocks that can be used to integrate Siemens drives (e.g. SIMOREG DC-MASTER) on the basis of a

speed interface into the SIMATIC PCS7 process control system. Operation and monitoring of the drive is then possible from the Operator Station

(OS). The PCS7 library can be used stand-alone, i.e. even without Drive ES Basic, with PCS7 versions V 5.0 and V 5.1.

Scope of supply	Order No.:	Type of delivery	Documentation
Drive ES software packages - For installation as an integral option of STEP 7 Versions \geq V 5.0			
Drive ES Basic V 5.0 ¹⁾ single-user license	6SW1700-0JA00-0AA0	CD-ROM, 1 unit	5 standard languages
Drive ES Graphic V 5.0 single-user license	6SW1700-0JB00-0AA0	CD-ROM, 1 unit	5 standard languages
Drive ES SIMATIC V 5.0 single-user license	6SW1700-0JC00-0AA0	CD-ROM, 1 unit	5 standard languages
Drive ES PCS7 V 5.1 single-user license	6SW1700-5JD00-1AA0	CD-ROM, 1 unit	5 standard languages
Drive ES software packages - For installation as an integral option of STEP 7 Versions \geq V 5.1			
Drive ES Basic V 5.1 ¹⁾ single-user license	6SW1700-5JA00-1AA0	CD-ROM, 1 unit	5 standard languages
Drive ES Basic Upgrade V 5.0 V \rightarrow 5.1 single-user license	6SW1700-5JA00-1AA4	CD-ROM, 1 unit	5 standard languages
Drive ES Basic V 5.1 copy/company license	6SW1700-5JA00-1AA1	CD-ROM, 1 unit	5 standard languages
Drive ES Graphic V 5.1 single-user license	6SW1700-5JB00-1AA0	CD-ROM, 1 unit	5 standard languages
Drive ES Graphic Upgrade V 5.0 \rightarrow 5.1 single-user license	6SW1700-5JB00-1AA4	CD-ROM, 1 unit	5 standard languages
Drive ES SIMATIC V 5.1 single-user license	6SW1700-5JC00-1AA0	CD-ROM, 1 unit	5 standard languages
Drive ES SIMATIC Upgrade V 5.0 \rightarrow 5.1 single-user license	6SW1700-5JC00-1AA4	CD-ROM, 1 unit	5 standard languages
Drive ES SIMATIC V 5.1 copy/runtime license	6SW1700-5JC00-1AC0	Only product certificate (without software and documentation)	5 standard languages
Drive ES PCS7 V 5.1 single-user license	6SW1700-5JD00-1AA0	CD-ROM, 1 unit	5 standard languages
Drive ES PCS7 V 5.1 copy/runtime license	6SW1700-5JD00-1AC0	Only product certificate (without software and documentation)	5 standard languages

Contents of the Drive ES SIMATIC package

- **Communication software "PROFIBUS-DP"** for S7-300 with CPUs with integrated DP interface (function block libraries DRVDPS7, POSMO) S7-400 with CPUs with integrated DP interface or with CP443-5 (function block library DRVDPS7, POSMO) S7-300 with CP342-5 (function block library DRVDPS7C)
- **Communication software "USS protocol"** for S7-200 with CPU 214/CPU 215/CPU 216 (DRVUSS2 driver program for STEP 7 Micro programming tool) S7-300 with CP 340/341 and S7-400 with CP 441 (function block library DRVUSSS7)
- **STEP 7 slave object manager** supports easy configuration of drives and non-cyclic PROFIBUS-DP communication with the drives, support for DVA_S7 conversion to Drive ES (only V 5.1 upwards)
- **SETUP program** for installing the software in the STEP 7 environment

Contents of the Drive ES PCS7 package (the PCS7 package can be used with PCS7 versions V 5.0 and V 5.1)

- **Function block library for SIMATIC PCS7** Display and control function blocks for SIMOREG DC-MASTER
- **STEP 7 slave object manager** supports easy configuration of drives and non-cyclic PROFIBUS-DP communication with the drives
- **SETUP program** for installing the software in the PCS7 environment

Software update service for Drive ES

A software update service can be ordered for the Drive ES software. For one year following the initial order, the customer automatically receives all the latest software, Service Packs and full versions without the need for any action.

Duration of the update service: 1 year

6 weeks before this period elapses, the customer and the relevant Siemens contact partner will be informed about the impending expiry in writing. It is then possible to reorder the update service for another year.

The update service can only be ordered for an existing full version.

Scope of supply	Order No.:
Software update service	
Drive ES Basic	6SW1700-0JA00-0AB2
Drive ES Graphic	6SW1700-0JB00-0AB2
Drive ES SIMATIC	6SW1700-0JC00-0AB2
Drive ES PCS7	6SW1700-0JD00-0AB2

¹⁾ Drive ES Basic can also be installed stand-alone w/o STEP 7 (for further information, see adjacent text).

SIMOREG 6RA70 DC MASTER

Options

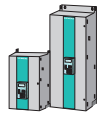

Performance options

SIMOREG 6RL70 rectifier module

Design

The SIMOREG uncontrolled rectifiers of Series 6RL70 were developed from the 6RA70 single-quadrant converters.

Diodes are installed instead of thyristors and the units do not contain any electronic modules. The fan voltage is 230 V (single-phase).

A KTY 84 temperature sensor for sensing the heat-sink temperature is wired to terminals to allow external evaluation of the signal. Semiconductor – cell fuses are integrated into the unit.

The units feature overload capability (60 s overload 1.36 % – 240 s previous load 0.91 %).

Application

In older installations, 12-pulse series circuits with rectifiers and thyristor converters are used. For retrofit projects, therefore, diode bridges can be required as partial converters in conjunction with standard converter units for supplying DC motors. Another (retrofit) application is for subsynchronous converter cascades.

The SIMOREG 6RL70 rectifier module is also suitable for supplying general DC loads that tolerate the use of an uncontrolled rectifier, e.g. DC links for converters in combination with a preloading unit, field supplies and galvanic applications.

Standards

DIN VDE 0106 Part 10	Protection against electric shock; location of actuators near live parts.
DIN VDE 0110 Part 1	Insulation coordination for electrical equipment in low-voltage installations. Requirements for safe isolation → Pollution severity 2 for boards and the power section. Only non-conductive pollution is permissible. Temporary conductivity must however be accepted due to condensation. "Dewing is not permitted because the components are only approved for Humidity Class F".
DIN VDE 0113 Part 1	Electrical equipment of industrial machines (where applicable).
DIN EN 50 178/DIN VDE 0160	Regulations for the equipment of electrical power installations with electronic equipment.
EN 61 000-4-2 and EN 61 000-4-4	Interference immunity
DIN IEC 60 068-2-6 acc. to degree of severity 12 (SN29 010 Part 1)	Mechanical stress

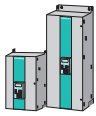

SIMOREG 6RA70 DC MASTER Options

Performance options

SIMOREG 6RL70 rectifier module - 3-ph. AC 690 V, 1000 A and 2000 A

Type	6RL70□□-□KS00	
	91-6	95-4
Rated supply voltage ³⁾	V	3-ph. AC 690 (+10% / -20%)
Rated input current	A	865
Rated supply voltage fan	V	1-ph. AC 230 (±10%) 50 Hz / 60 Hz
Nominal fan current	A	2.6 / 3.3
Fan noise level	dB(A)	85 / 87
Air flow rate	m ³ /h	1400
Rated DC voltage	V	930
Rated DC current	A	1000
		2000
Rating Class II acc. to EN 60 146-1-1 ¹⁾		
Rated output current mean value	A	910
Base-load duty period	s	240
Output overcurrent mean value	A	1365
		2720
Overcurrent duration	s	60
Rated output	kW	930
Power loss at rated DC current (approx.)	W	3.12
		4.94
Operational ambient temperature	°C	0 to 40 at I_{rated} separately cooled ²⁾
Storage and transport temperature	°C	-25 to +70
Installation altitude above sea level		≤ 1000 m at rated DC current ⁴⁾
Environment class	DIN IEC 721-3-3	3K3
Degree of protection	DIN 40 050 IEC 60 144	IP 00
See dimension drawing on Page	mm	8/13
Weight (approx.)	kg	82
		142

4

1) Duty cycle

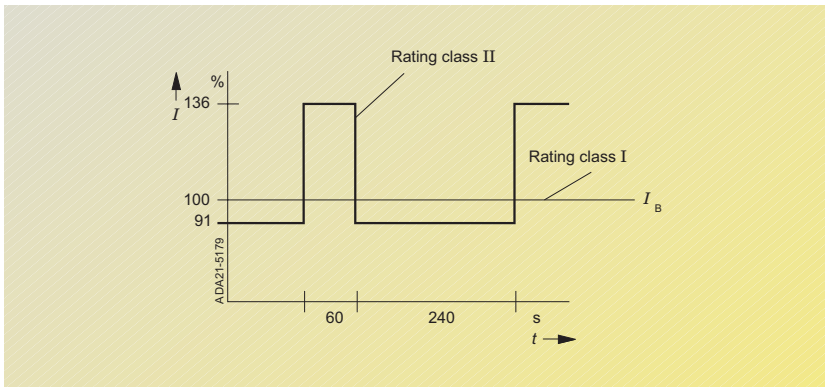

2) Load factor K1 (DC current) as a function of the coolant temperature. $K1 > 1$ only permissible where $K1 * K2 \leq 1$ st. overall reduction factor $K = K1 * K2$ (for K2 see Footnote 2).

Ambient or coolant temperature	Load factor K1	
	In devices with self-cooling	In devices with enhanced cooling
≤ +30 °C	1.18	1.10
+35 °C	1.12	1.05
+40 °C	1.06	1.00
+45 °C	1.00	0.95
+50 °C	0.94	0.90
+55 °C	0.88	
+60 °C	0.82	

to the rated supply voltage (with a corresponding output voltage).

4) Load values K2 as a function of the installation altitude. Overall reduction factor $K = K1 * K2$ (for K1 see Footnote 2)

Installation altitude m	1000	2000	3000	4000	5000
Reduction factor K2	1.0	0.835	0.74	0.71	0.67

The supply voltages for all electric circuits are possible for site altitudes up to 5000 m with basic insulation.

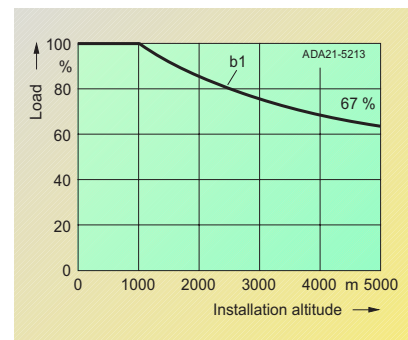

Curve b1: Reduction factor of load values (DC current) at installation altitudes above 1000 m.

3) The rectifier can be operated with voltages up

SIMOREG 6RA70 DC MASTER

Options

Notes

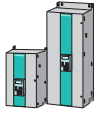

4

SIMOREG 6RA70 DC MASTER

Planning guide

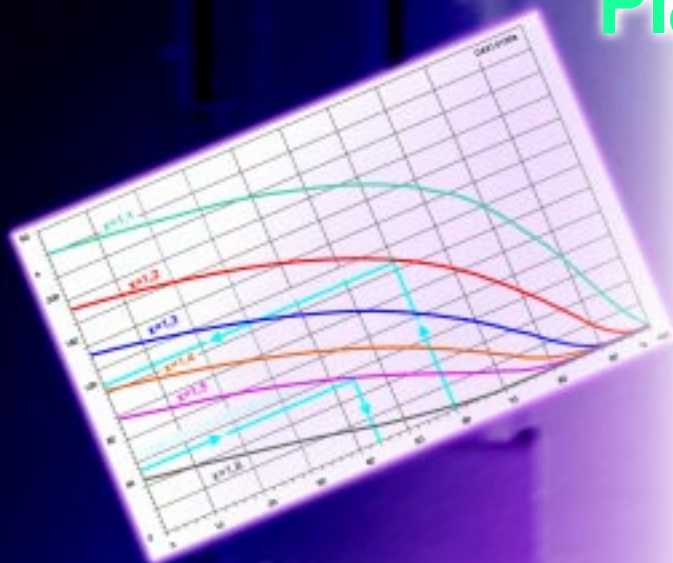

- 5/2 **Dynamic overload capability**
Calculation of dynamic overload capability
- 5/14 Rating classes
- 5/15 Load cycles for single-quadrant applications
- 5/16 Load cycles for four-quadrant applications

- 5/17 **Parallel connection**
Parallel connection of SIMOREG DC MASTER converters
- 5/17 Redundancy mode
- 5/17 Terminal connections for parallel connection

5/18 **12-pulse operation**

5/18 **Supplying high inductances**

5/18 **Condensation protection**

Characteristic data of pulse evaluation electronics

- 5/19 Level of input pulses
- 5/19 Switching frequency
- 5/19 Cable, cable length, shield connection

Instructions for the electromagnetically compatible installation of drives

- 5/20 Fundamentals of EMC
- 5/21 Electromagnetically compatible installation
- 5/22 Cabinet arrangement and shielding

Components

- 5/23 Components for converters
- 5/24 Single-phase commutating reactors
- 5/24 Three-phase commutating reactors
- 5/25 Radio interference suppression filters

5/26 **Harmonics**

SIMOREG 6RA70 DC MASTER

Planning Guide

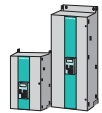

Dynamic overload capability

Calculation of dynamic overload capability

Overview of function

The rated DC current (= maximum permissible continuous DC current) specified on the converter rating plate may be exceeded in operation. The amount by which the rated value may be exceeded and for what period are explained in more detail below.

The absolute upper limit for the absolute overload current corresponds to 1.8 times the DC current rating.

The maximum overload period depends both on the time characteristic of the overload current and on the load history of the converter and is specific to individual units.

Every overload must be preceded by an "underload" (load phase with load current < rated DC current). After the maximum permissible overload period has expired, the load current must be reduced to a value at least \leq rated DC current.

The dynamic overload period is made possible by a thermal monitoring function (I^2t monitor) in the power section. This I^2t monitor uses the time characteristic of the actual load current to calculate the time characteristic of an equivalent value for the thyristor junction temperature over ambient temperature. Converter-specific characteristics (e.g. thermal resistance and time constants) are included in the calculation. When the converter is switched on, the calculation commences with the initial values that were calculated before the converter power supply was last switched off or last failed. Allowance for ambient conditions (ambient temperature and installation altitude) can be made via a parameter setting.

The I^2t monitor responds if the calculated equivalent junction temperature exceeds the permitted value. Two alternative reactions can be parameterized:

- Alarm with reduction of armature current setpoint to rated DC current or
- Fault with shutdown of converter.

The I^2t monitor can be switched off. In this case, the armature current is limited to the rated DC current.

Planning of dynamic overload capability

The planning sheets contain the following information:

- The maximum overload period t_{an} for starting with cold power section and specified constant overload
- The maximum current interval t_{ab} (maximum cooling time) until the power section reaches the "cold" state
- Limit characteristic fields for calculating overload capability in thermally settled, intermittent overload operation (periodic load cycles).

Note: The power section is in the "cold" state when the calculated equivalent junction temperature corresponds to less than 5% of its maximum permissible value. This state can be scanned via a binary selectable output.

Structure of limit characteristic fields for intermittent overload operation

Each characteristic field refers to a load cycle of intermittent overload operation with a total period of 300 s. This type of load cycle consists of two periods, i.e. the base-load duty period (actual armature current \leq rated DC current) and the overload duty period (actual armature current \geq rated DC current).

Each limit characteristic represents the maximum base-load current specified as a percentage of rated DC current) for a certain overload factor over the minimum base-load duty period (limit base-load duty period) for a specific unit. For the remainder of the load cycle, the maximum permissible current then corresponds to the overload current determined by the overload factor. If no limit characteristic is specified for the desired overload factor, then the characteristic for the next higher overload factor is applicable.

The families of limit characteristics are valid for a load cycle period of 300 s. However, simple rules of calculation can be applied to configure load cycles that are longer or shorter than 300 s. These are illustrated below by two basic planning tasks.

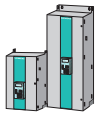

Calculation of dynamic overload capability

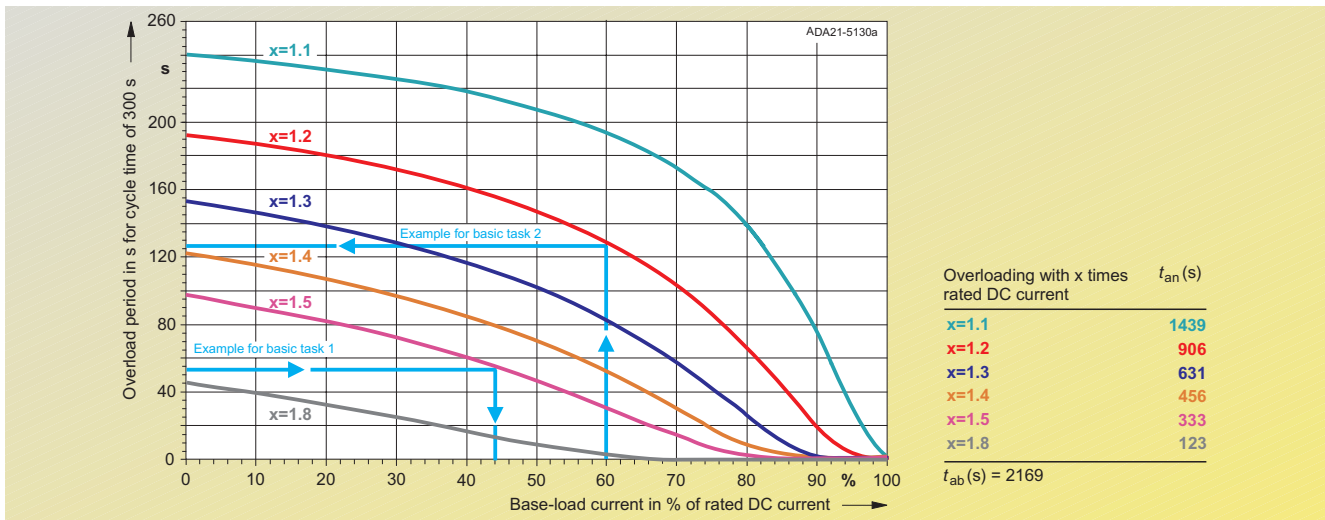

Fig. 5/1
Characteristics for example calculations for basic tasks 1 and 2

Basic task 1

- Known quantities:
Converter, cycle time, overload factor, overload period
- Quantities to be found:
(min.) base-load duty period and max. base-load current
- Solution:
See Table 2

Example for basic task 1

- Known quantities:
 - 30 A converter
 - Cycle time 113.2 s
 - Overload factor 1.45
 - Overload period 20 s
- Quantities to be found:
 - (min.) base-load duty period
 - max. base-load current
- Solution:
 - Limit characteristic for 30 A converter
 - Overload factor 1.5
 - Overload period₃₀₀ = 300 s / (113.2 s) × 20 s = 53 s ->
 - Max. base-load current = 44% I_{rated} = 13.2 A

Basic task 2

- Known quantities:
Converter, cycle time, overload factor, base-load current
- Quantities to be found:
Maximum overload period, minimum base-load period
- Solution: See Table 3

	Definition
Base-load duty period₃₀₀	Min. base-load duty period for 300 s cycle time (300 s overload period)
Overload period₃₀₀	Max. overload period for 300 s cycle time

Table 1
Explanation of terms

	Cycle time	
	< 300 s	≥ 300 s
1. Determine curve	Selection of limit characteristic for specific converter and overload factor (see Fig. 5/1)	
2. Overload period₃₀₀ =	300 s/cycle time × overload period	Overload period ₃₀₀
3. Base-load duty period₃₀₀ =	300 s overload period ₃₀₀	300 s overload period ₃₀₀
4. Base-load duty period₃₀₀ < base-load duty period₃₀₀ for max. base-load current = 0	Yes: Required cycle time not configurable No: Read off max. baseload current for overload period ₃₀₀ from limit characteristic	
5. Determine percentage for base-load current	Read of percentage for base-load current from diagram	

Table 2
Steps to solve basic task 1

	Cycle time	
	< 300 s	≥ 300 s
1. Determine curve	Selection of limit characteristic for specific converter and overload factor (see Fig. 5/1)	
2. Max. overload period =	(cycle time/300 s) × overload period ₃₀₀	300 s base-load duty period ₃₀₀
3. Min. base-load period =	Cycle time - max. overload period	Cycle time - max. overload period

Table 3
Steps to solve basic task 2
Example for basic task 2

- Known quantities:
 - 30 A converter
 - Cycle time 140 s
 - Overload factor 1.15
 - Base-load current = 0.6 I_{rated} = 18 A

- Quantities to be found:
 - Max. overload period
 - Min. base-load period
- Solution:
 - Limit characteristic for 30 A converter
 - Overload factor 1.2
 - Base-load current = 60% I_{rated} ->
 - Overload period₃₀₀ = 127 s
 - Max. overload period = (140 s/300 s) × 127 s = 59 s
 - Min. base-load duty period = 140 s - 59 s = 81 s

SIMOREG 6RA70 DC MASTER

Planning Guide

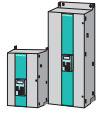

Dynamic overload capability

Calculation of dynamic overload capability

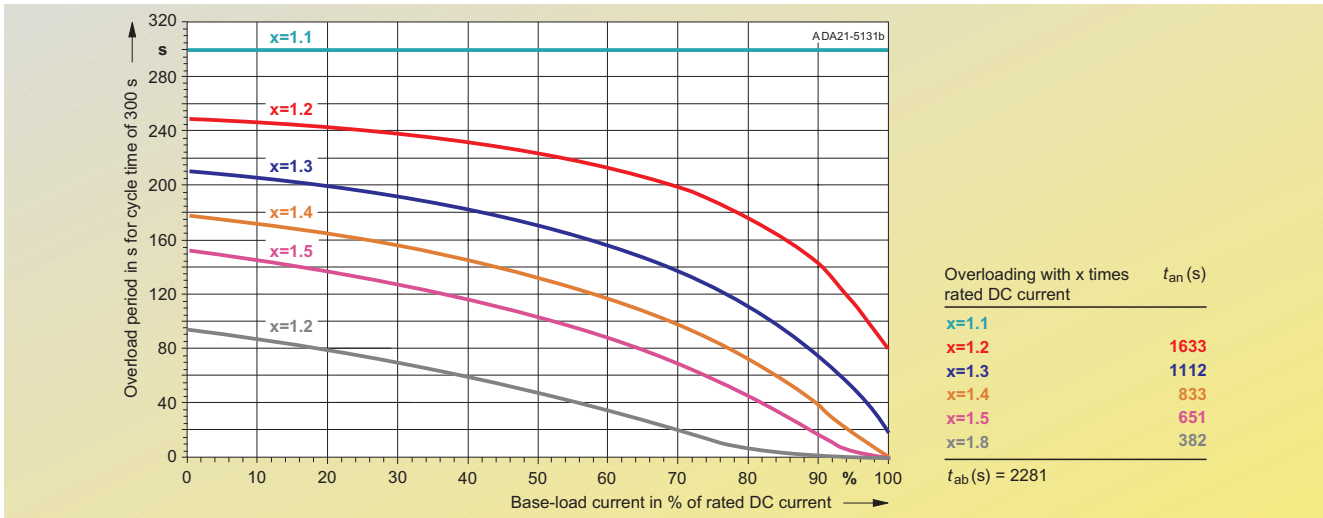

Fig. 5/2
6RA7013-6DV62 15 A/400 V

5

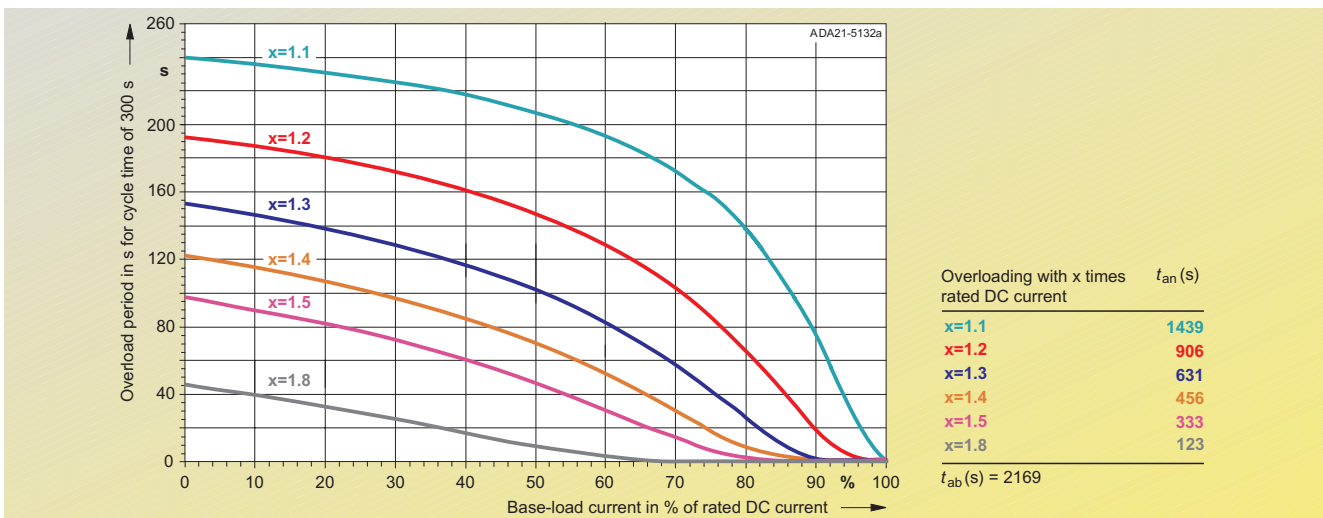

Fig. 5/3
6RA7018-6DS22 30 A/1Q/400 V, 6RA7018-6FS22 30 A/1Q/460 V, 6RA7018-6DV62 30 A/4Q/400 V, 6RA7018-6FV62 30 A/4Q/460 V

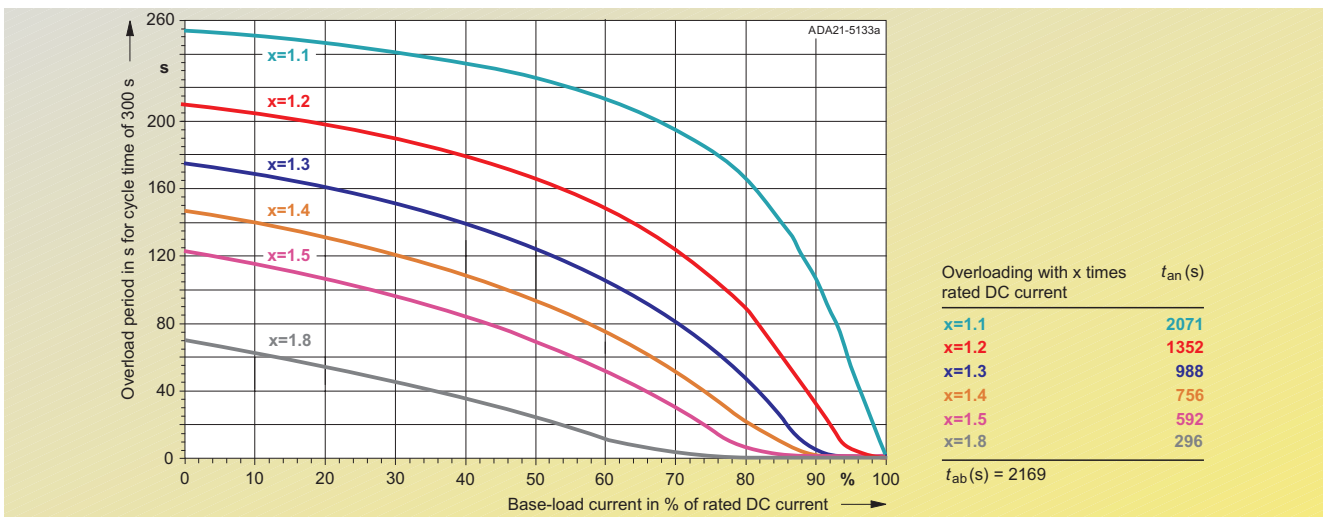
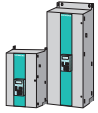

Fig. 5/4
6RA7025-6DS22 60 A/1Q/400 V, 6RA7025-6FS22 60 A/1Q/460 V, 6RA7025-6GS22 60 A/1Q/575 V



Calculation of dynamic overload capability

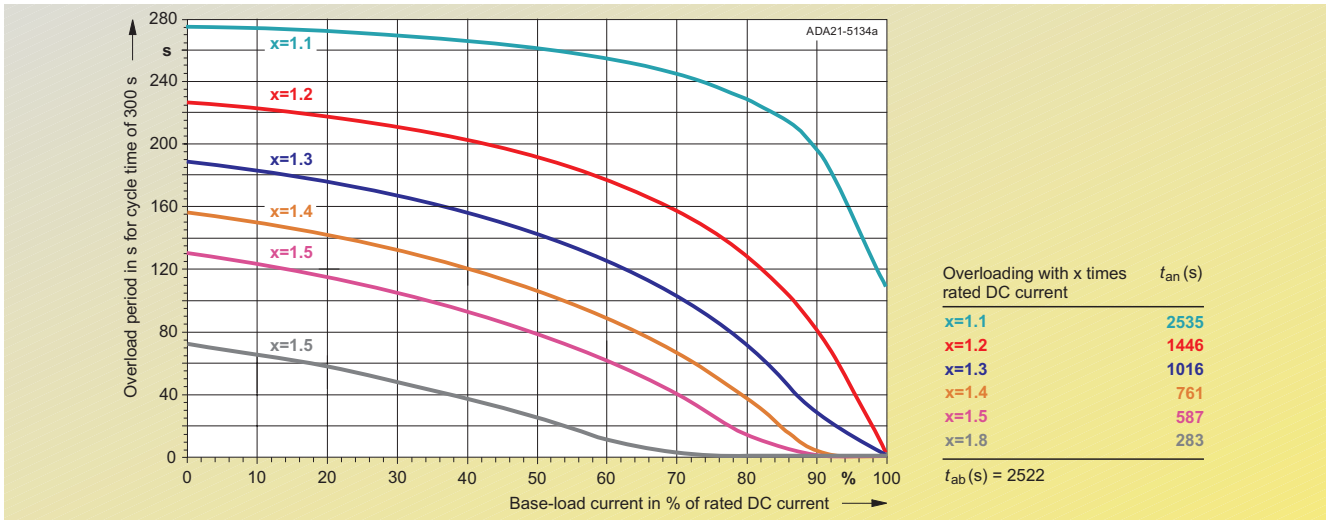

Fig. 5/5
6RA7025-6DV62 60 A/4Q/400 V, 6RA7025-6FV62 60 A/4Q/460 V, 6RA7025-6GV62 60 A/4Q/575 V

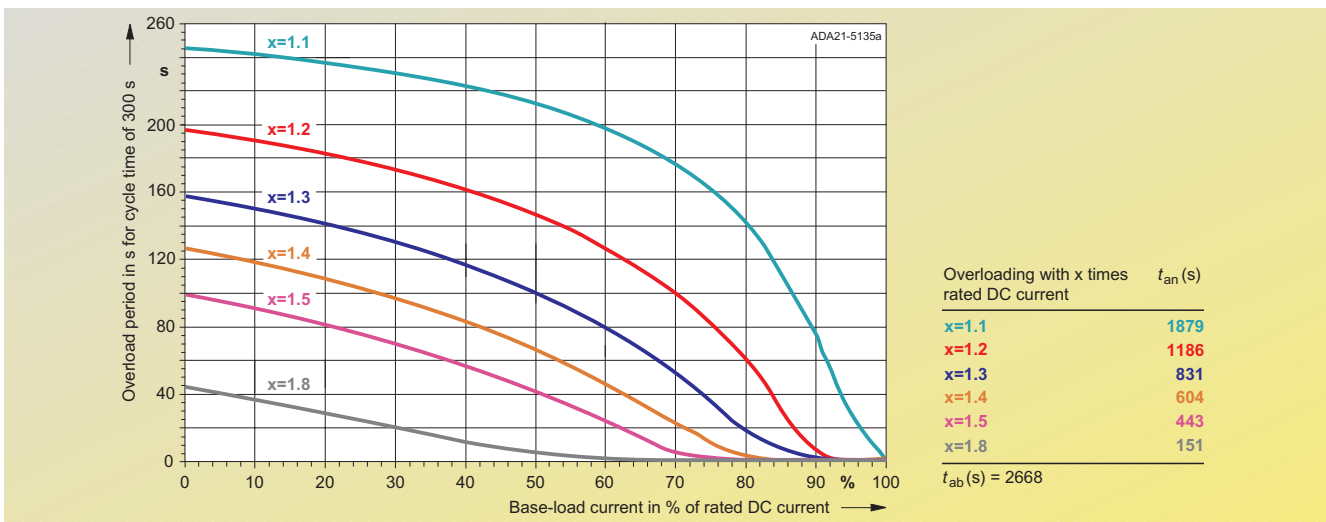

Fig. 5/6
6RA7028-6DS22 90 A/1Q/400 V, 6RA7028-6FS22 90 A/1Q/460 V

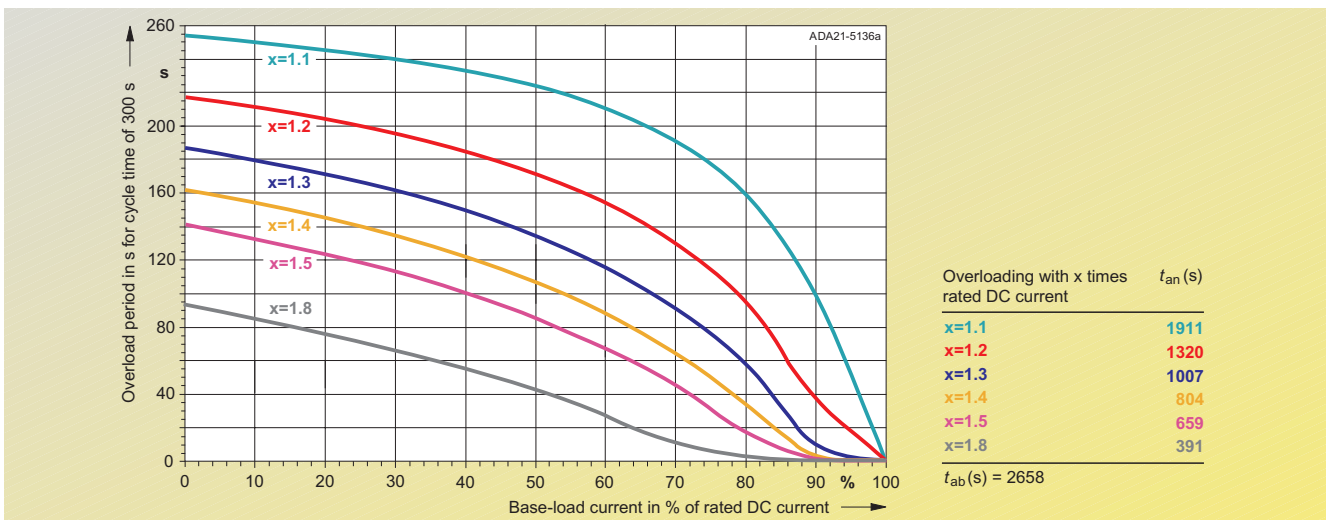
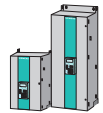

Fig. 5/7
6RA7028-6DV62 90 A/4Q/400 V, 6RA7028-6FV62 90 A/4Q/460 V

SIMOREG 6RA70 DC MASTER

Planning Guide



Dynamic overload capability

Calculation of dynamic overload capability

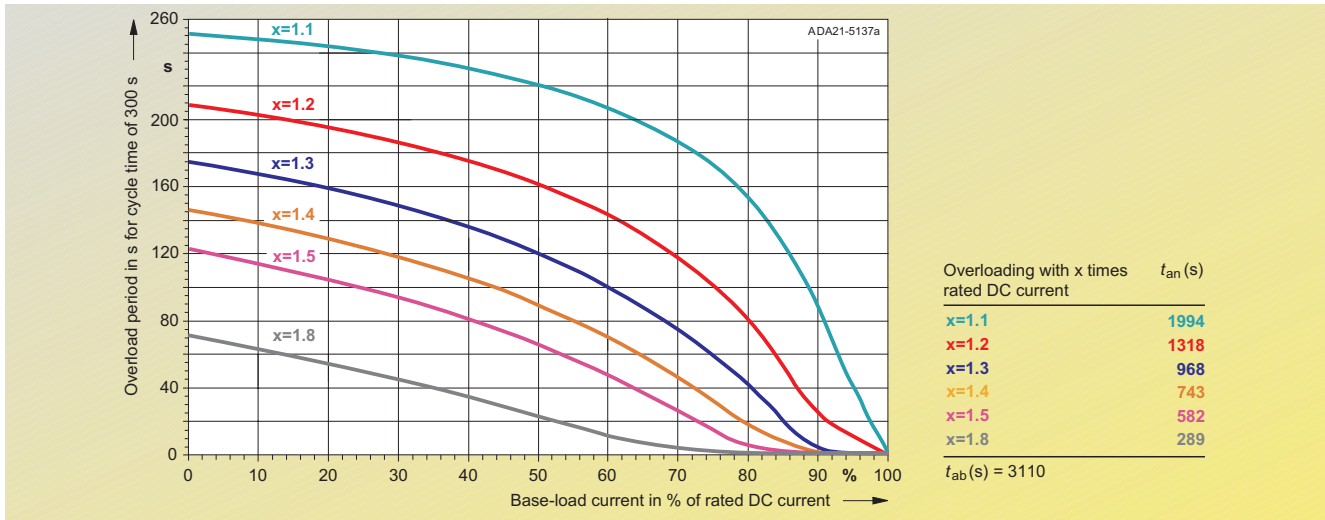

Fig. 5/8
6RA7031-6DS22 125 A/1Q/400 V, 6RA7031-6FS22 125 A/1Q/460 V, 6RA7031-6GS22 125 A/1Q/575 V

5

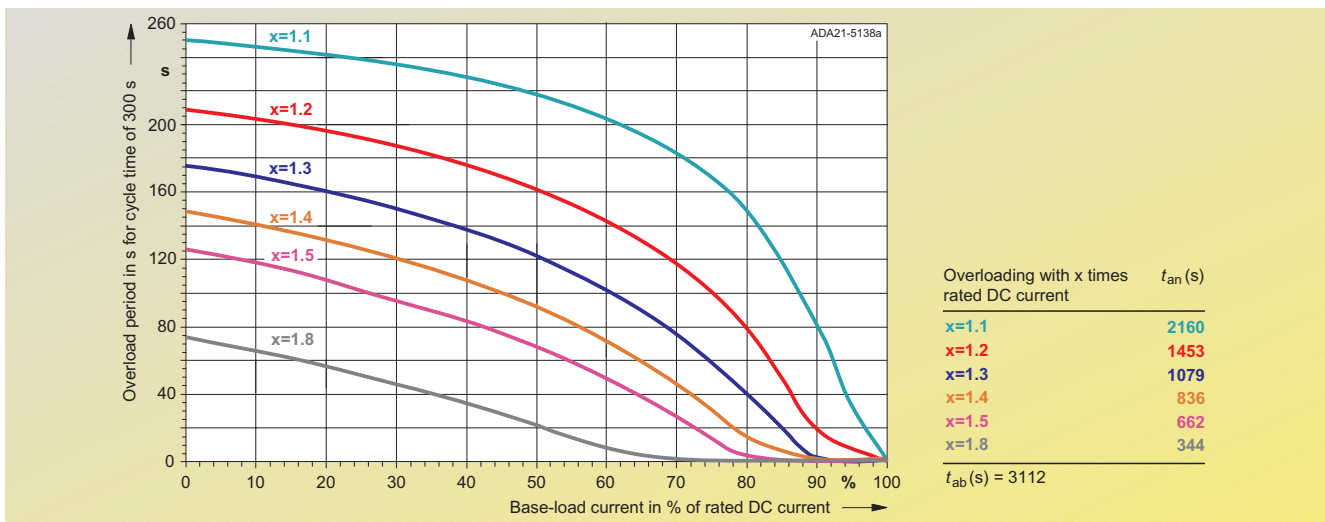

Fig. 5/9
6RA7031-6DV62 125 A/4Q/400 V, 6RA7031-6FV62 125 A/4Q/460 V, 6RA7031-6GV62 125 A/4Q/575 V

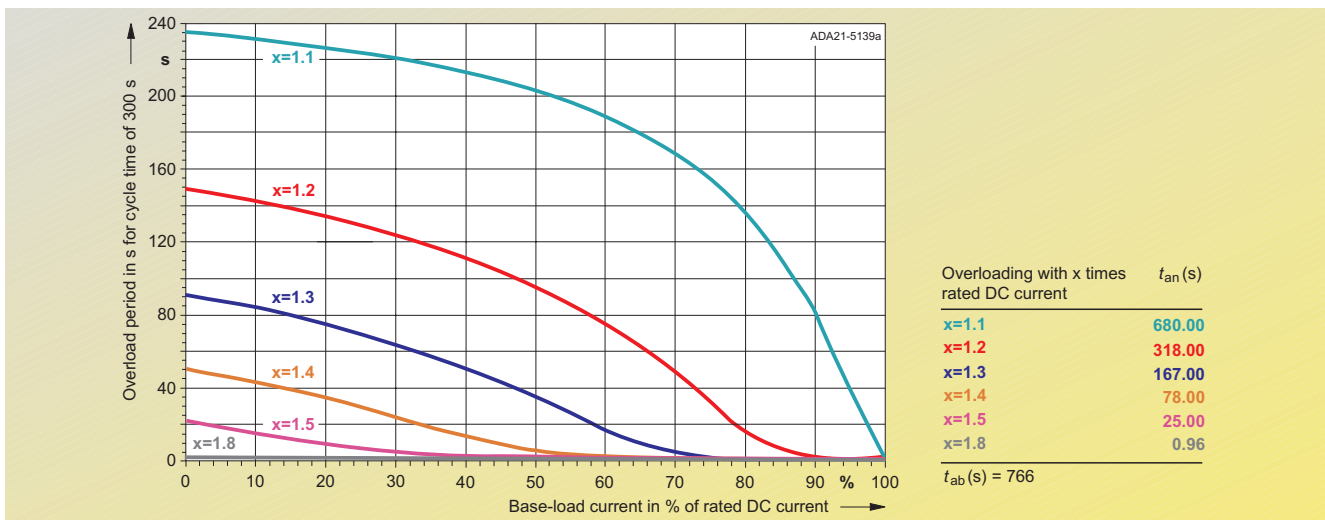
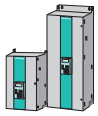

Fig. 5/10
6RA7075-6DS22 210 A/1Q/400 V, 6RA7075-6FS22 210 A/1Q/460 V, 6RA7075-6GS22 210 A/1Q/575 V,
6RA7075-6DV62 210 A/4Q/400 V, 6RA7075-6FV62 210 A/4Q/460 V, 6RA7075-6GV62 210 A/4Q/575 V



Calculation of dynamic overload capability

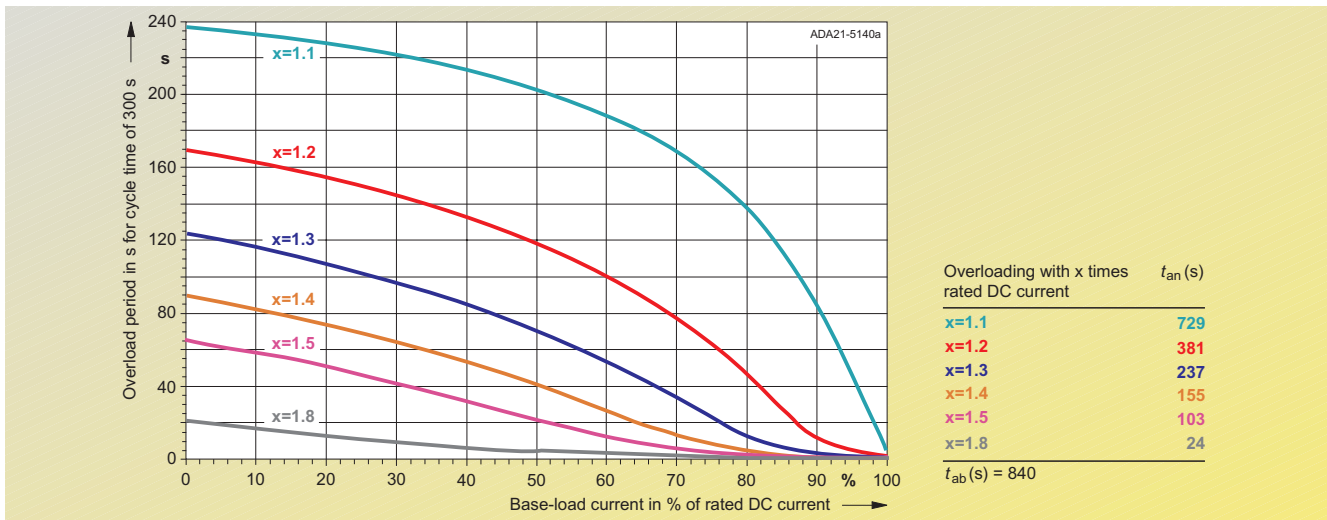

Fig. 5/11
6RA7078-6DS22 280 A/1Q/400 V, 6RA7078-6FS22 280 A/1Q/460 V, 6RA7078-6DV62 280 A/4Q/400 V, 6RA7078-6FV62 280 A/4Q/460 V

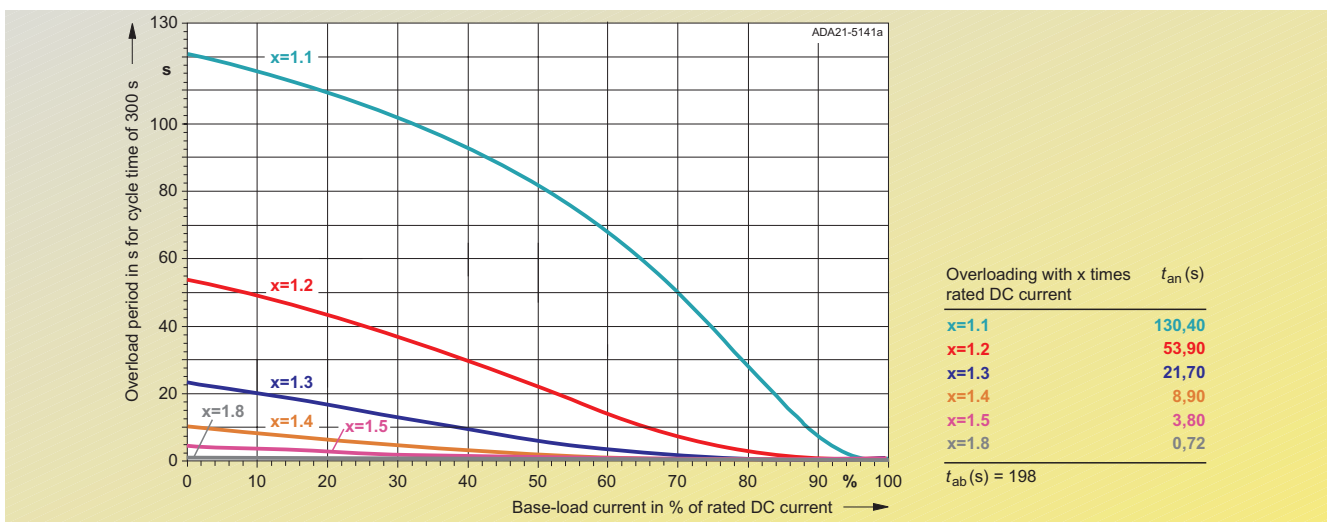

Fig. 5/12
6RA7081-6DS22 400 A/1Q/400 V, 6RA7081-6GS22 400 A/1Q/575 V

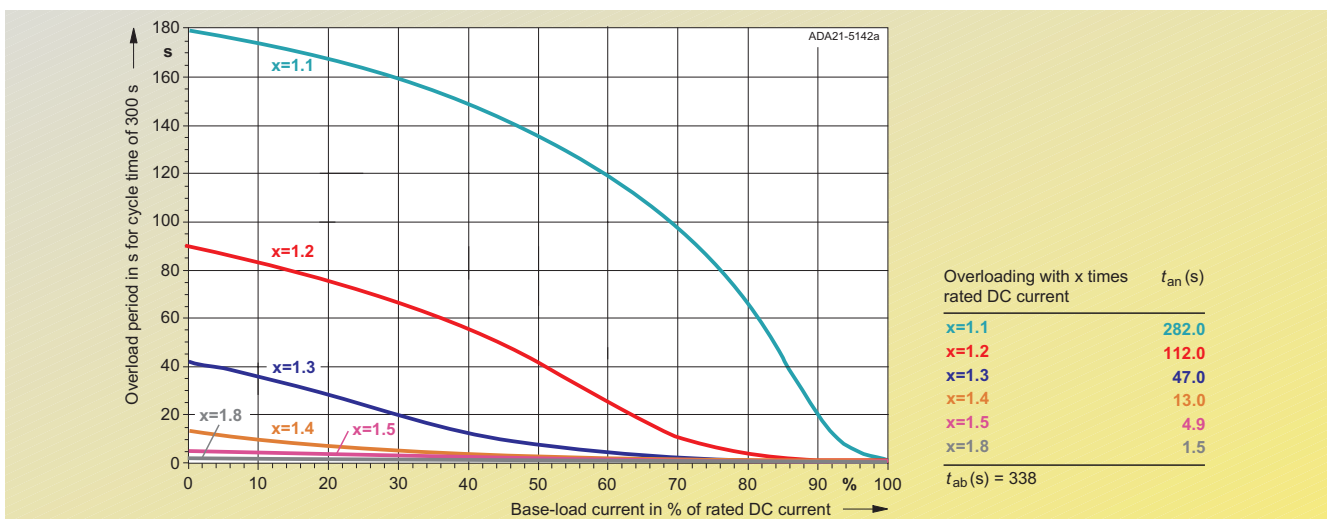
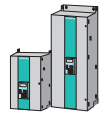

Fig. 5/13
6RA7081-6DV62 400 A/4Q/400 V, 6RA7081-6GV62 400 A/4Q/575 V

SIMOREG 6RA70 DC MASTER

Planning Guide



Dynamic overload capability

Calculation of dynamic overload capability

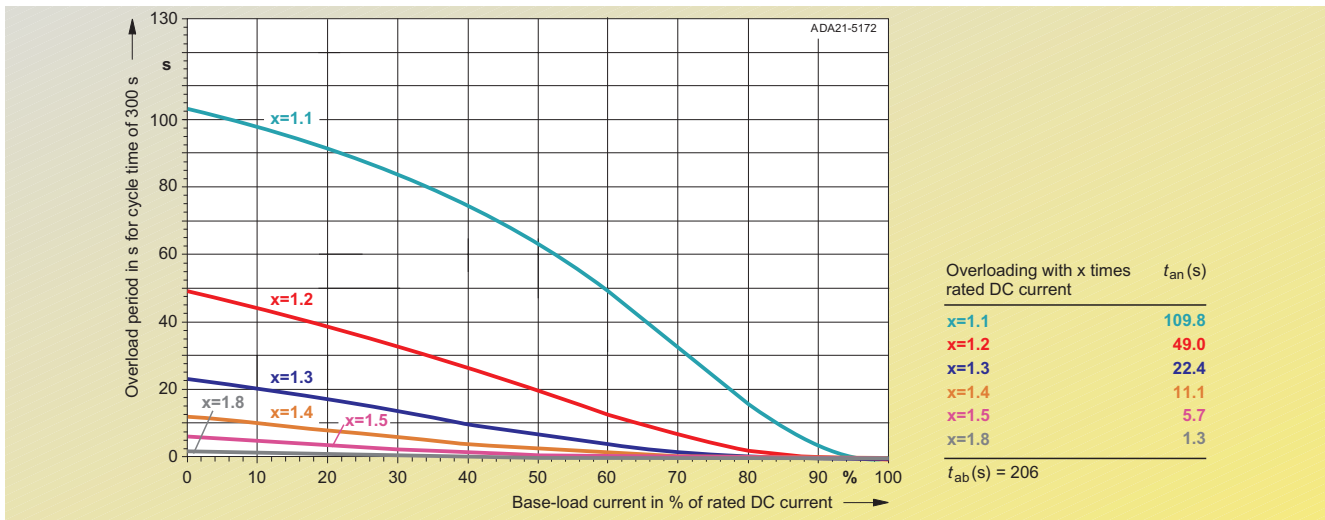

Fig. 5/14
6RA7082-6FS22 450 A/1Q/460 V, 6RA7082-6FV62 450 A/4Q/460 V

5

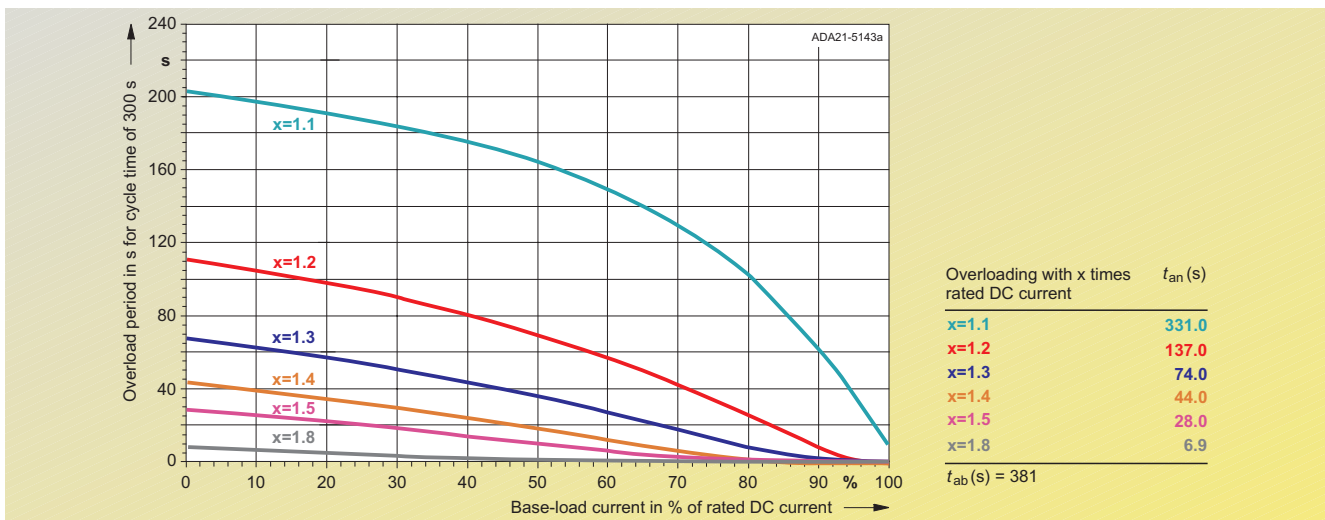

Fig. 5/15
6RA7085-6DS22 600 A/1Q/400 V, 6RA7085-6FS22 600 A/1Q/460 V, 6RA7085-6GS22 600 A/1Q/575 V

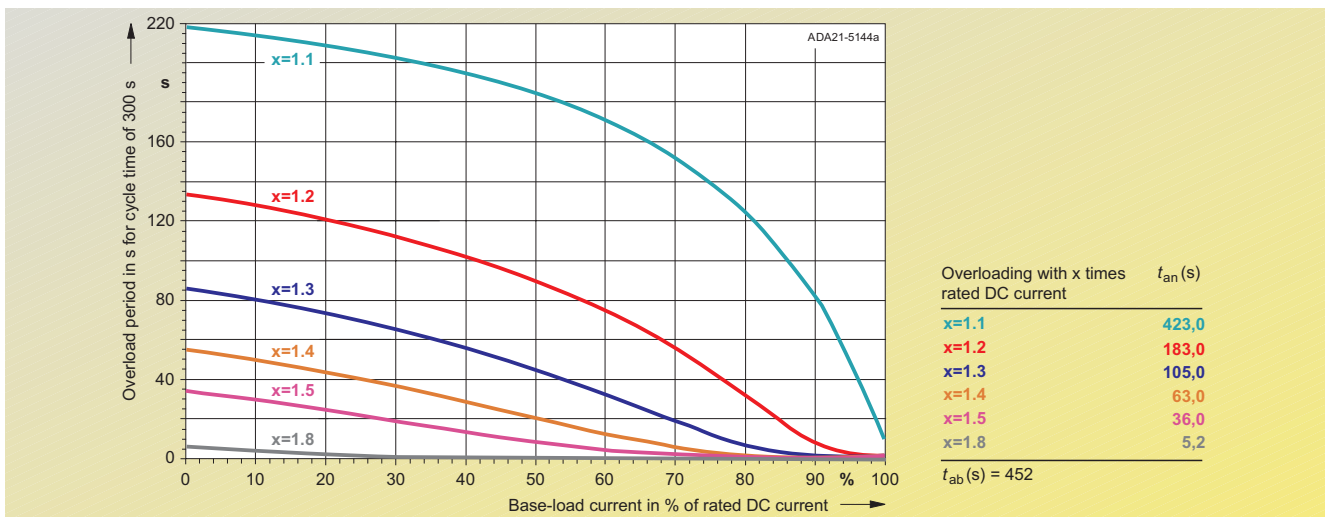
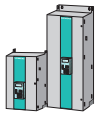

Fig. 5/16
6RA7085-6DV62 600 A/4Q/400 V, 6RA7085-6FV62 600 A/4Q/460 V, 6RA7085-6GV62 600 A/4Q/575 V



Calculation of dynamic overload capability

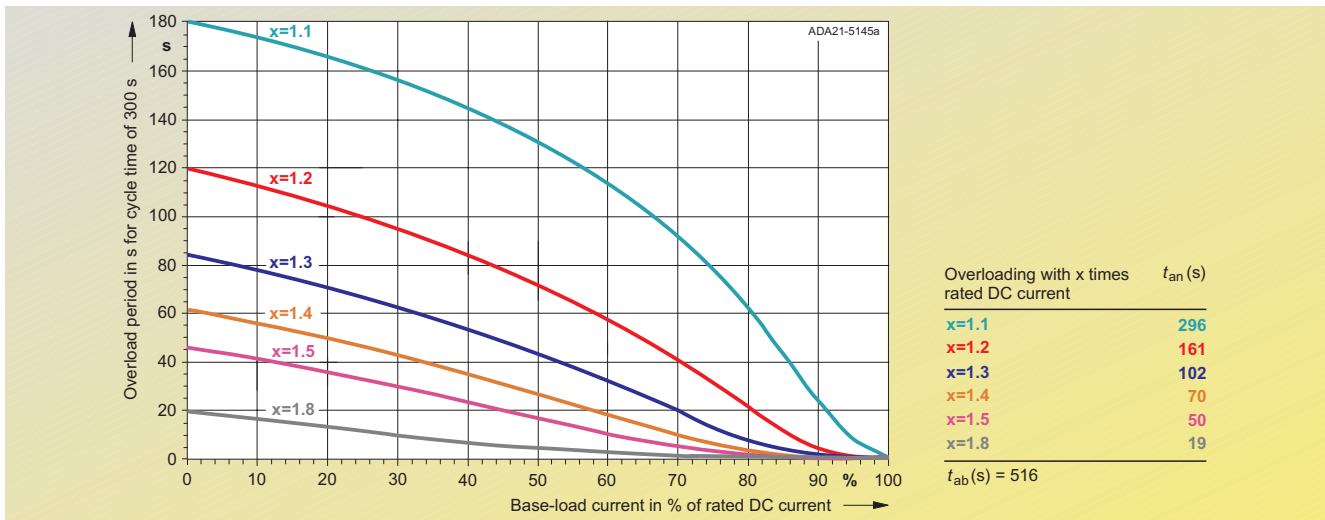

Fig. 5/17
6RA7087-6DS22 850 A/1Q/400 V, 6RA7087-6FS22 850 A/1Q/460 V, 6RA7087-6GS22 800 A/1Q/575 V, 6RA7086-6KS22 720 A/1Q/690 V

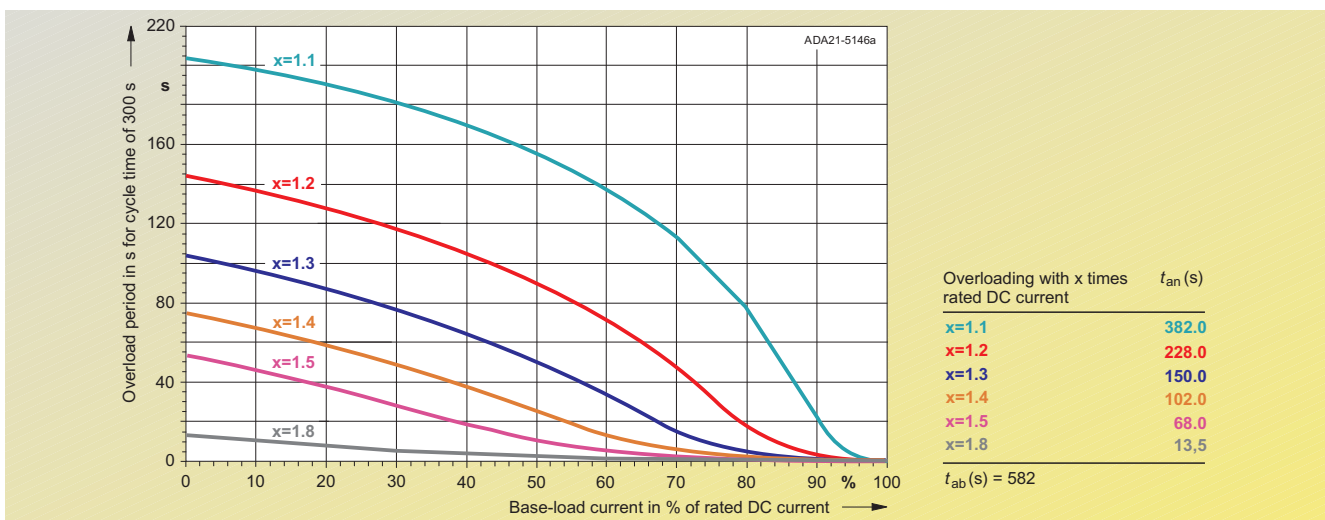

Fig. 5/18
6RA7087-6DV62 850 A/4Q/400 V, 6RA7087-6FV62 850 A/4Q/460 V, 6RA7087-6GV62 850 A/4Q/575 V, 6RA7086-6KV62 760 A/4Q/690 V

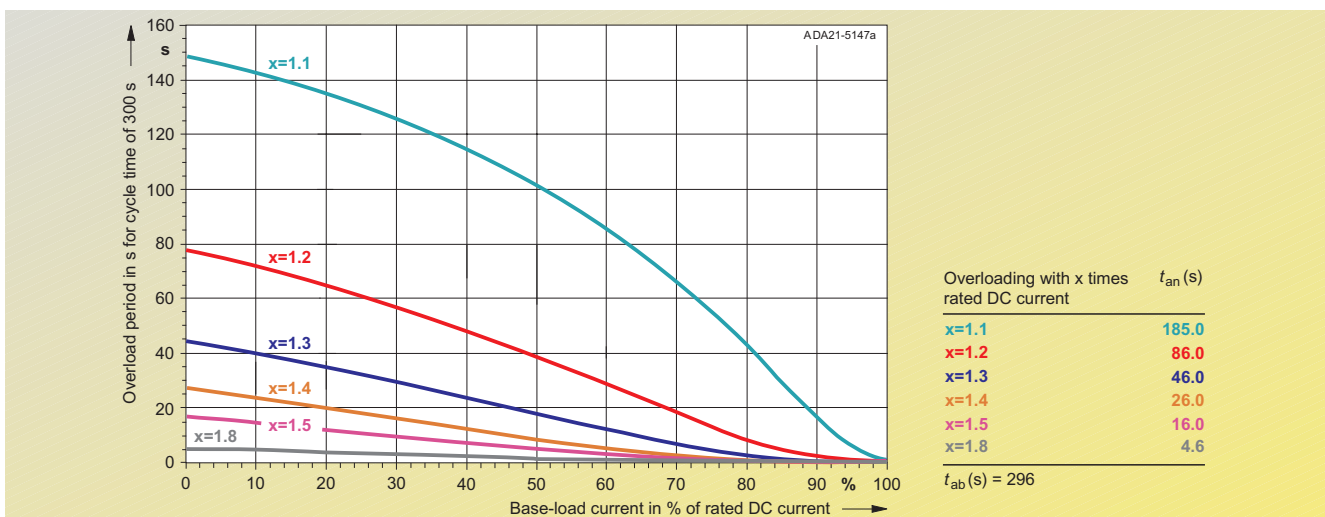
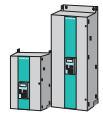

Fig. 5/19
6RA7090-6GS22 1000 A/1Q/575 V, 6RA7088-6KS22 950 A/1Q/690 V, 6RA7088-6LS22 900 A/1Q/830 V

SIMOREG 6RA70 DC MASTER

Planning Guide



Dynamic overload capability

Calculation of dynamic overload capability

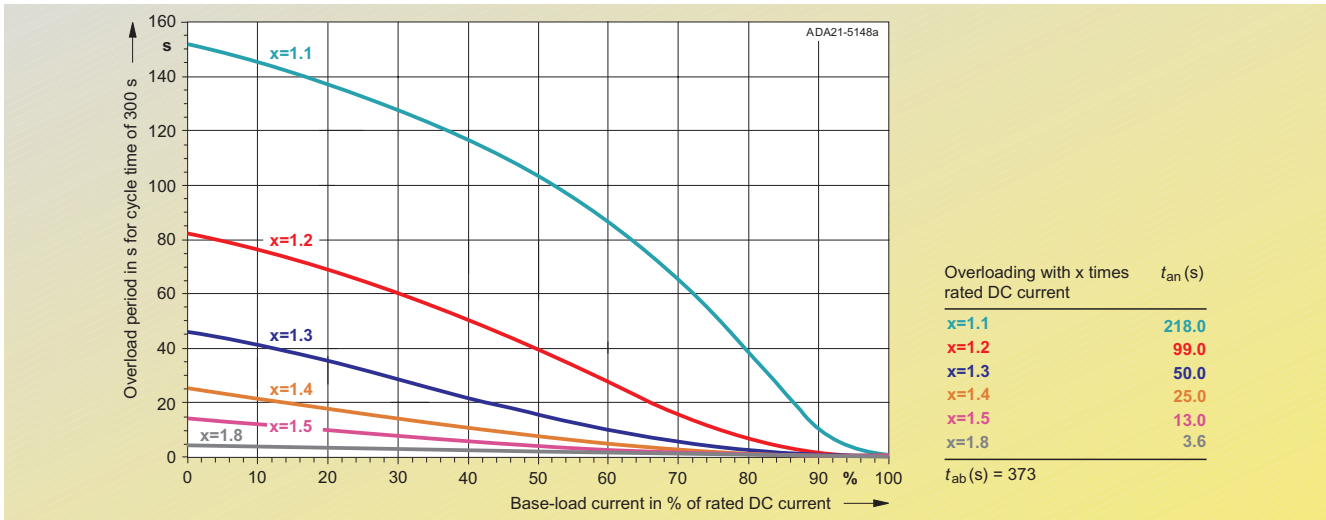

Fig. 5/20
6RA7090-6KV62 1000 A/4Q/690 V, 6RA7088-6LV62 950 A/4Q/830 V

5

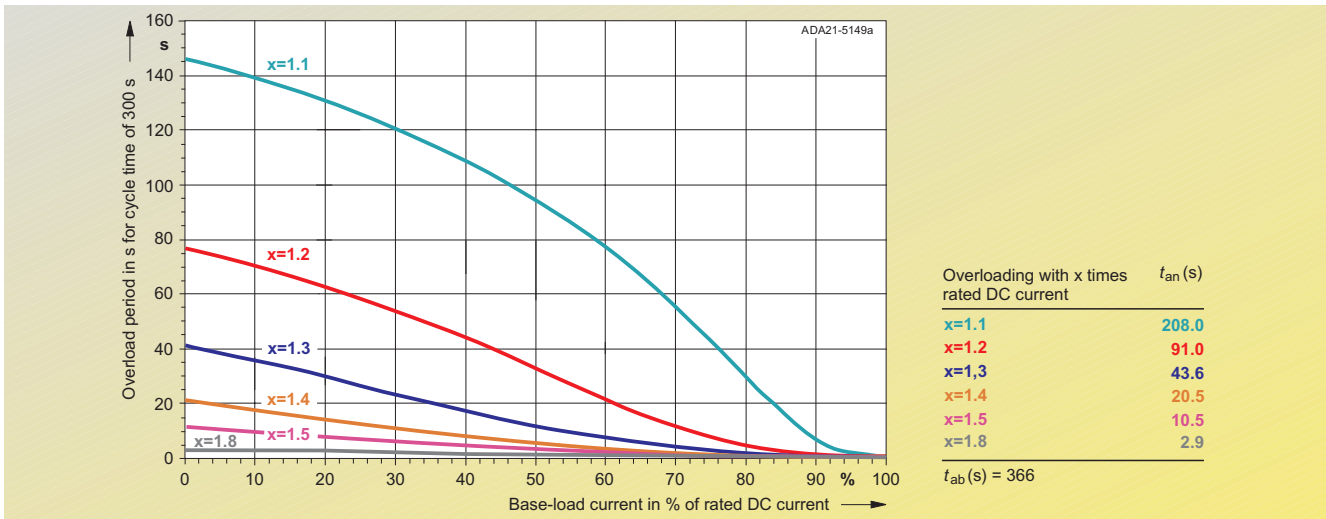

Fig. 5/21
6RA7090-6GV62 1100 A/4Q/575 V

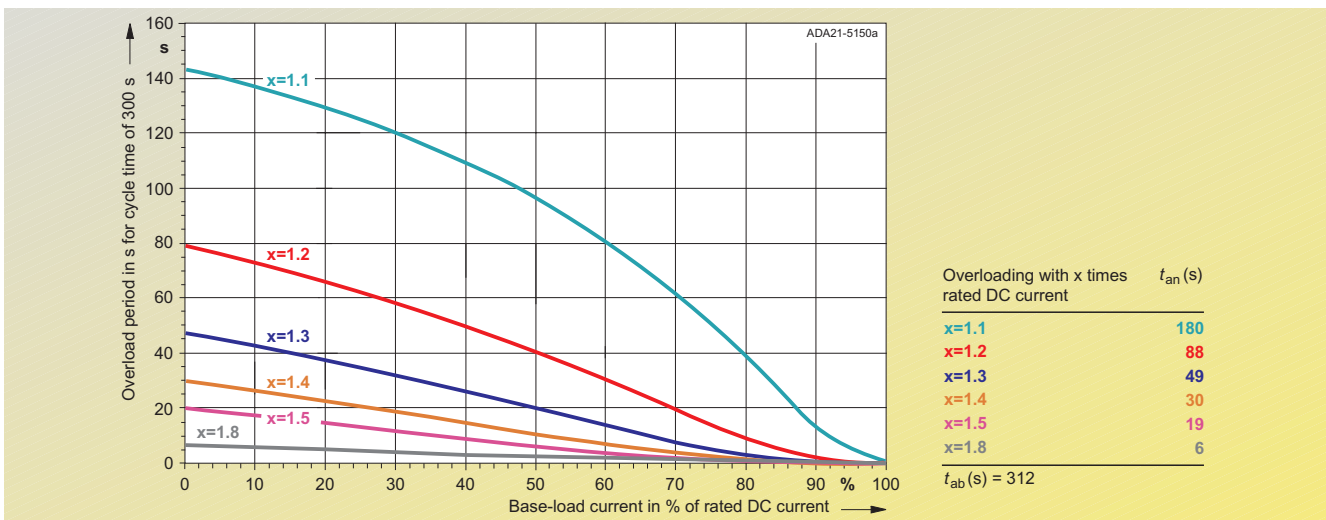
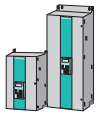

Fig. 5/22
6RA7091-6DS22 1200 A/1Q/400 V, 6RA7091-6FS22 1200 A/1Q/460 V



Calculation of dynamic overload capability

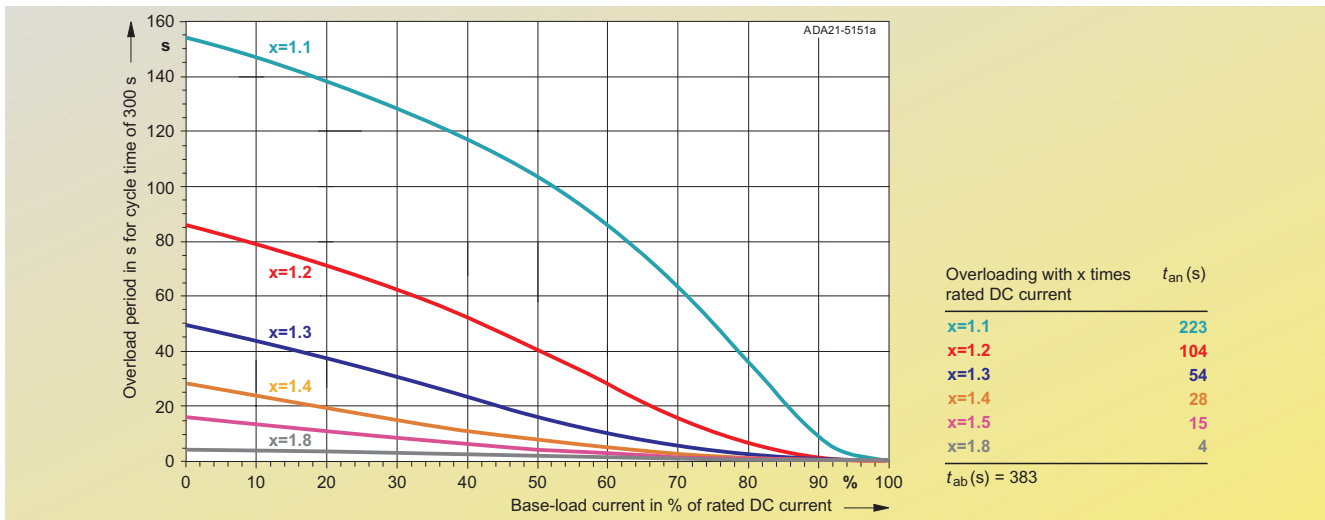

Fig. 5/23
6RA7091-6DV62 1200 A/4Q/400 V, 6RA7091-6FV62 1200 A/4Q/460 V

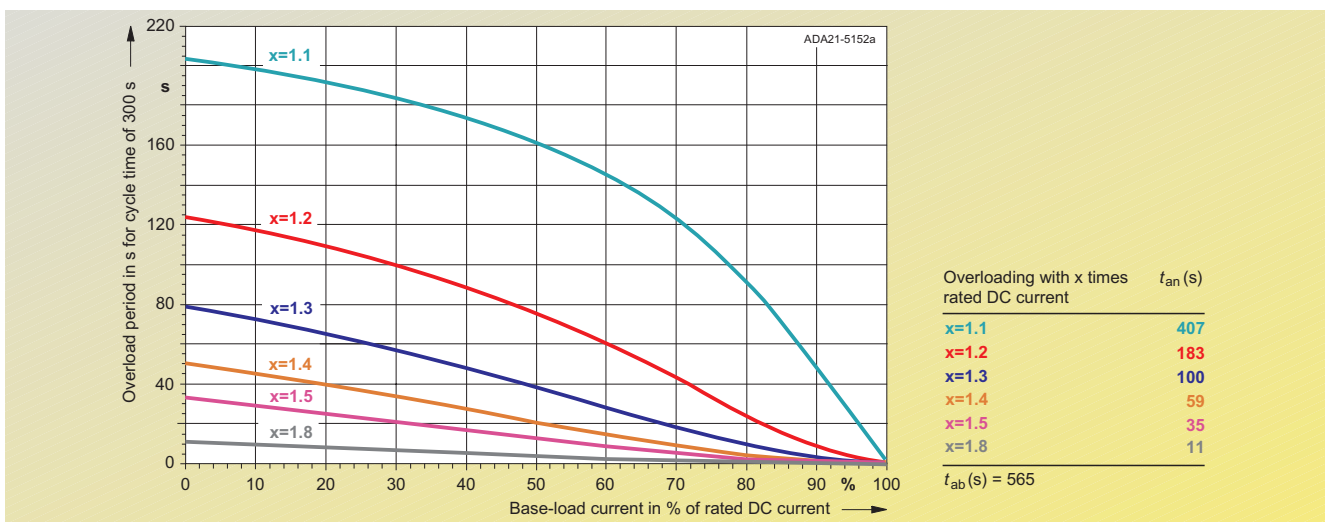

Fig. 5/24
6RA7093-4KS22 1500 A/1Q/690 V, 6RA7093-4LS22 1500 A/1Q/830 V

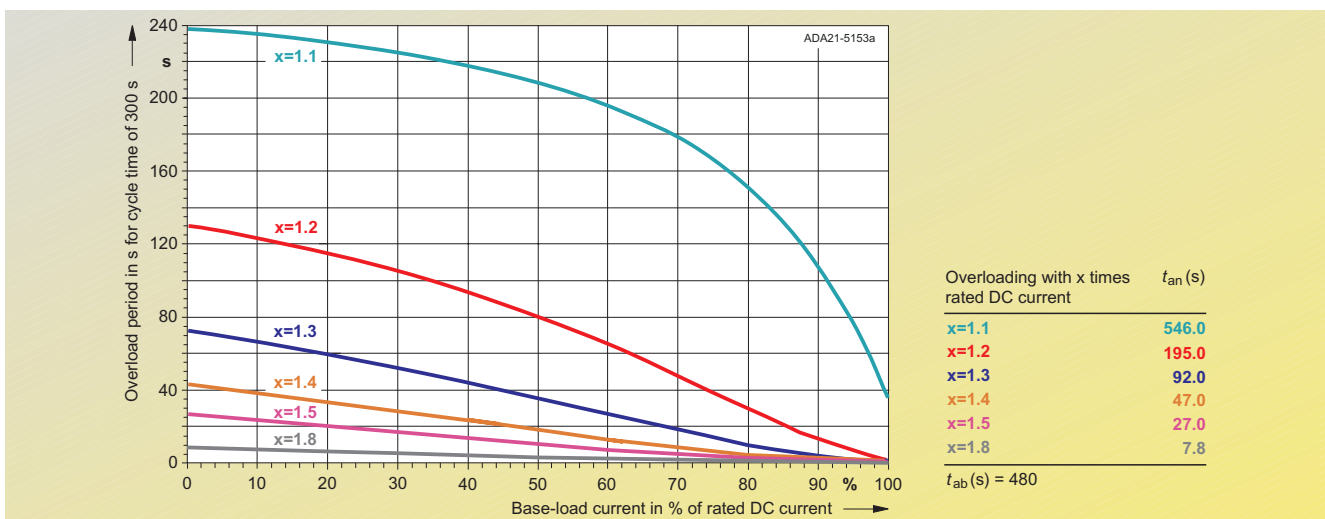
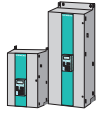

Fig. 5/25
6RA7093-4KV62 1500 A/4Q/690 V, 6RA7093-4LV62 1500 A/4Q/830 V

SIMOREG 6RA70 DC MASTER

Planning Guide



Dynamic overload capability

Calculation of dynamic overload capability

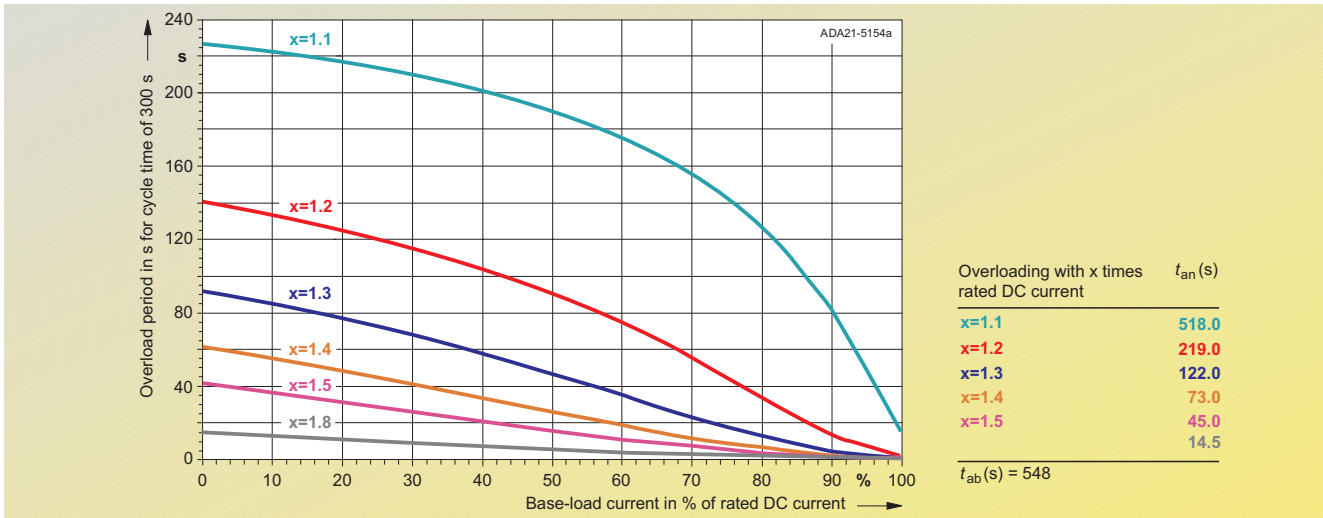

Fig. 5/26
6RA7093-4DS22 1600 A/1Q/400 V, 6RA7093-4GS22 1600 A/1Q/575 V, 6RA7093-4DV62 1600 A/4Q/400 V, 6RA7093-4GV62 1600 A/4Q/575 V

5

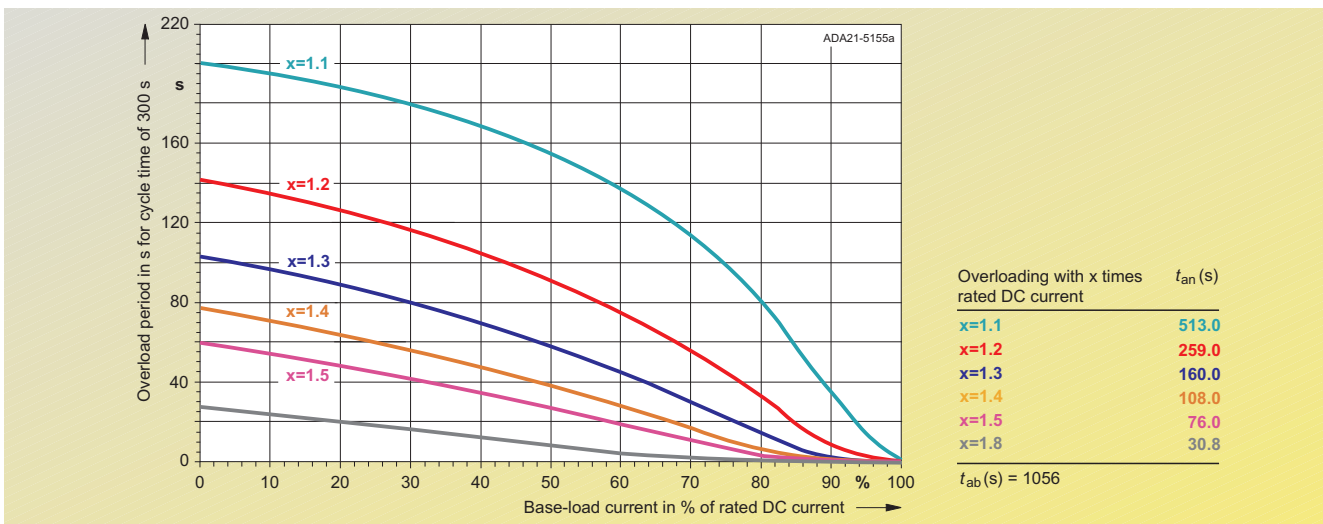

Fig. 5/27
6RA7095-4LS22 1900 A/1Q/830 V, 6RA7095-4LV62 1900 A/4Q/830 V

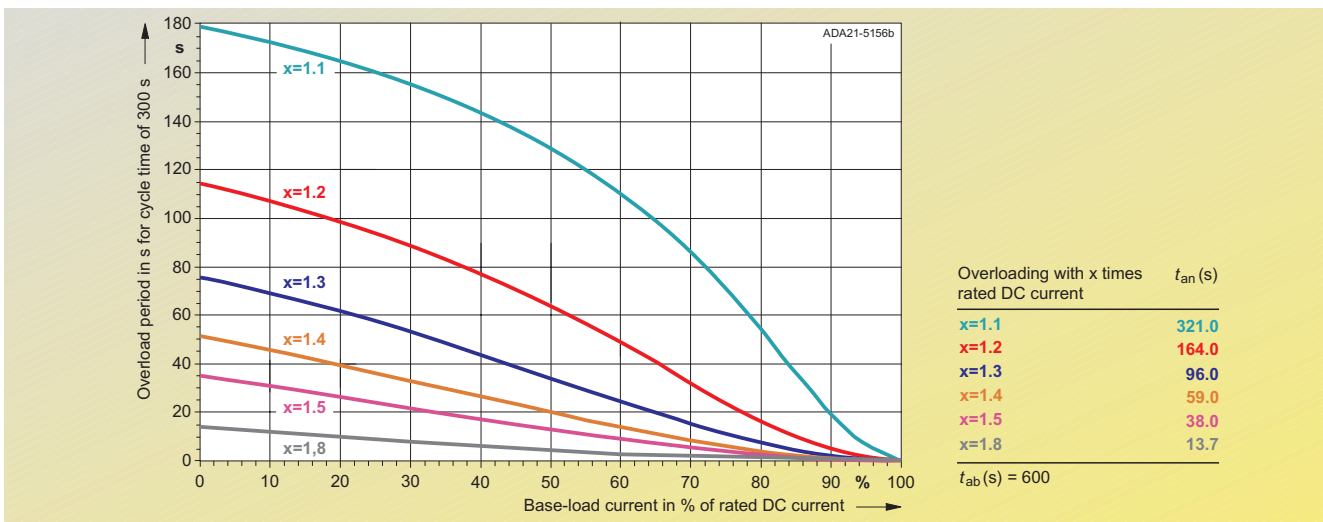
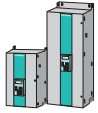

Fig. 5/28
6RA7095-4DS22 2000 A/1Q/400 V, 6RA7095-4GS22 2000 A/1Q/575 V



Calculation of dynamic overload capability

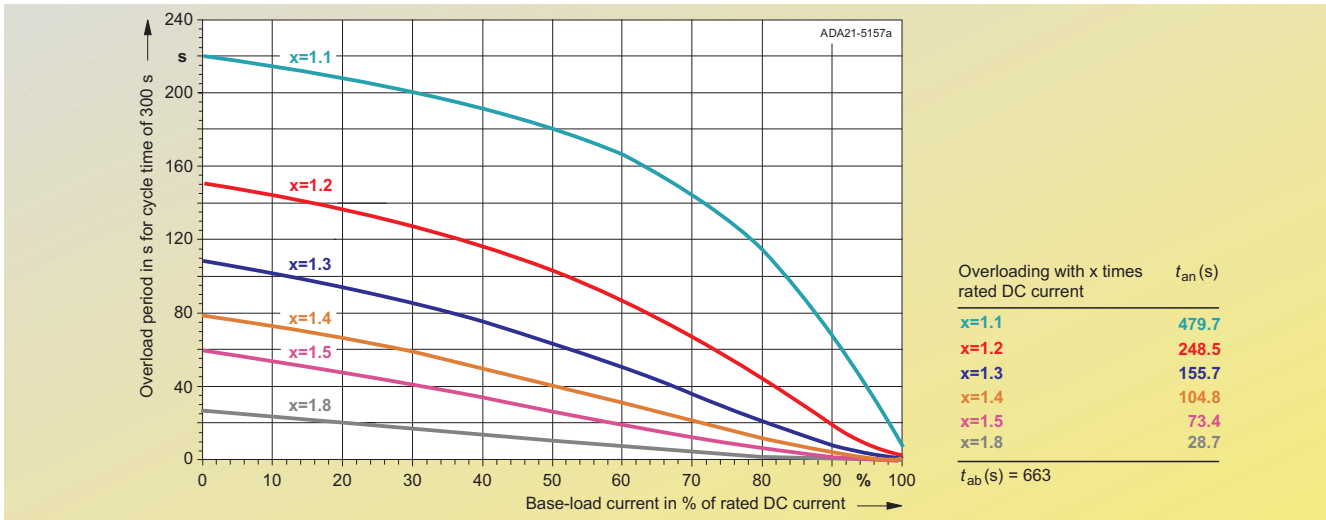

Fig. 5/29
6RA7095-4KS22 2000 A/1Q/690 V

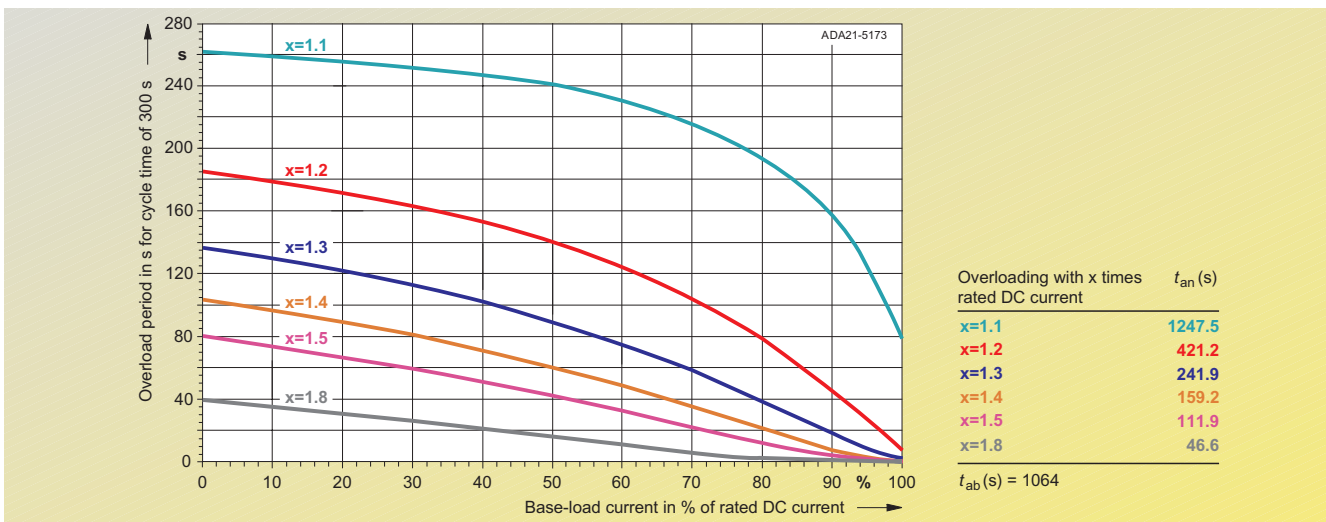

Fig. 5/30
6RA7095-4GS22 2000 A/1Q/575 V, 6RA7095-4GV62 2000 A/4Q/575 V

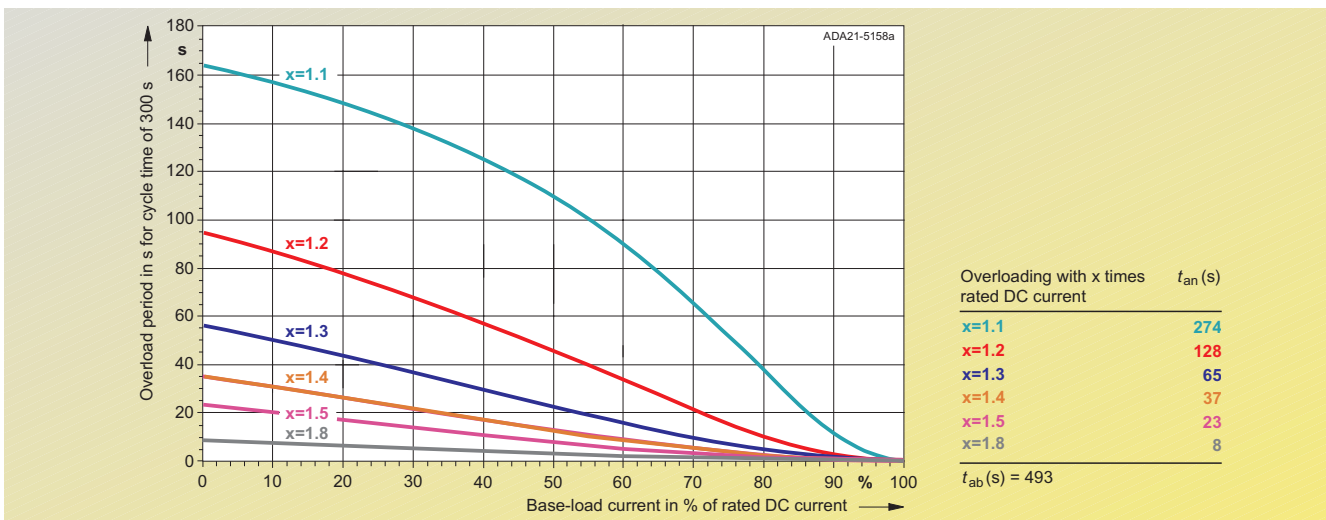
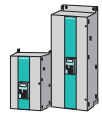

Fig. 5/31
6RA7095-4DV62 2000 A/4Q/400 V, 6RA7095-4GV62 2000 A/4Q/575 V, 6RA7095-4KV62 2000 A/4Q/690 V

SIMOREG 6RA70 DC MASTER

Planning Guide



Dynamic overload capability

Rating classes

To enable the SIMOREG DC MASTER converters to be adapted to the loading profile of the machine as easily as possible, they can – in addition to individual dimensioning on the basis of the limit curves for dynamic overload capability – also be dimensioned using preset and easily parameterized load cycles.

The adjustment is made on the SIMOREG DC Master using Parameter P067.

Note

The SIMOREG DC Master does not monitor compliance with the rating class set using parameter P067. If the power section permits it, longer overload periods than specified by the rating class can also be used. In this case, however, there is no protection for the driven machine or the mechanical system against overloading!

The overload duration actually permitted for the specific power section is always larger than the overload duration corresponding to the rating class. Compliance with the overload duration actually permitted for the power section is monitored by the SIMOREG DC Master.

Rating class (Parameter)	Load for converter	Load cycle
DC I (P067=1)	$I_{DC I}$ continuous (I_{dN})	
DC II (P067=2)	$I_{DC II}$ for 15 min and $1.5 \times I_{DC II}$ for 60 s	
DC III (P067=3)	$I_{DC III}$ for 15 min and $1.5 \times I_{DC III}$ for 120 s	
DC IV (P067=4)	$I_{DC IV}$ for 15 min and $2 \times I_{DC IV}$ for 10 s	
US Rating (P067=5)	I_{US} for 15 min and $1.5 \times I_{US}$ for 60 s <u>Note</u> With this setting, an ambient temperature or coolant temperature of 45 °C is permitted for all converter types.	

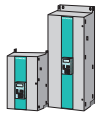

SIMOREG 6RA70 DC MASTER Planning Guide

Dynamic overload capability

Load cycles for single-quadrant applications

Recommended SIMOREG DC Master	T_u	Load cycles										
		DC I	DC II			DC III		DC IV		US Rating $T_u = 45^\circ\text{C}$		
			Continu- ous	15 min 100%	60 s 150%	15 min 100%	120 s 150%	15 min 100%	10 s 200%	15 min 100%	60 s 150%	
Type	$^\circ\text{C}$	A	A	A	A	A	A	A	A	A	A	
400 V, 1Q	6RA7018-6DS22	45	30	25.0	37.5	24.0	36.0	22.4	44.8	25.0	37.5	
	6RA7025-6DS22	45	60	51.0	76.5	50.0	75.0	46.5	93.0	51.0	76.5	
	6RA7028-6DS22	45	90	74.0	111.0	72.0	108.0	66.0	132.0	74.0	111.0	
	6RA7031-6DS22	45	125	105.0	158.0	100.0	150.0	95.0	190.0	105.0	158.0	
	6RA7075-6DS22	40	210	165.0	247.5	161.0	241.5	137.0	274.0	158.0	237.0	
	6RA7078-6DS22	40	280	227.0	340.5	218.0	327.0	202.0	404.0	216.0	324.0	
	6RA7081-6DS22	40	400	290.0	435.0	281.0	421.5	244.0	488.0	276.0	414.0	
	6RA7085-6DS22	40	600	463.0	694.5	446.0	669.0	415.0	830.0	443.0	664.5	
	6RA7087-6DS22	40	850	652.0	978.0	622.0	933.0	610.0	1220.0	620.0	930.0	
	6RA7091-6DS22	40	1200	880.0	1320.0	850.0	1275.0	790.0	1580.0	850.0	1275.0	
	6RA7093-4DS22	40	1600	1250.0	1875.0	1210.0	1815.0	1140.0	2280.0	1190.0	1785.0	
	6RA7095-4DS22	40	2000	1510.0	2265.0	1454.0	2181.0	1390.0	2780.0	1436.0	2154.0	
460 V, 1Q	6RA7018-6FS22	45	30	25.0	37.5	24.0	36.0	22.4	44.8	15.0	22.5	
	6RA7025-6FS22	45	60	51.0	76.5	50.0	75.0	46.5	93.0	30.0	45.0	
	6RA7028-6FS22	45	90	74.0	111.0	72.0	108.0	66.0	132.0	60.0	90.0	
	6RA7031-6FS22	45	125	105.0	158.0	100.0	150.0	95.0	190.0	100.0	150.0	
	6RA7075-6FS22	40	210	165.0	247.5	161.0	241.5	137.0	274.0	140.0	210.0	
	6RA7078-6FS22	40	280	227.0	340.5	218.0	327.0	202.0	404.0	210.0	315.0	
	6RA7082-6FS22	40	450	320.0	480.0	311.0	466.5	275.0	550.0	255.0	382.5	
	6RA7085-6FS22	40	600	463.0	694.5	446.0	669.0	415.0	830.0	430.0	645.0	
	6RA7087-6FS22	40	850	652.0	978.0	622.0	933.0	610.0	1220.0	510.0	765.0	
	6RA7091-6FS22	40	1200	880.0	1320.0	850.0	1275.0	790.0	1580.0	850.0	1275.0	
	575 V, 1Q	6RA7025-6GS22	45	60	51.0	76.5	50.0	75.0	46.5	93.0	51.0	76.5
		6RA7031-6GS22	45	125	105.0	158.0	100.0	150.0	95.0	190.0	105.0	158.0
6RA7075-6GS22		40	210	165.0	247.5	161.0	241.5	137.0	274.0	158.0	237.0	
6RA7081-6GS22		40	400	290.0	435.0	281.0	421.5	244.0	488.0	276.0	414.0	
6RA7085-6GS22		40	600	463.0	694.5	446.0	669.0	415.0	830.0	443.0	664.5	
6RA7087-6GS22		40	800	608.0	912.0	582.0	873.0	560.0	1120.0	578.0	867.0	
6RA7090-6GS22		40	1000	736.0	1104.0	714.0	1071.0	652.0	1304.0	700.0	1050.0	
6RA7093-4GS22		40	1600	1250.0	1875.0	1210.0	1815.0	1140.0	2280.0	1190.0	1785.0	
6RA7095-4GS22		40	2000	1660.0	2490.0	1590.0	2385.0	1570.0	3140.0	1660.0	2490.0	
690 V, 1Q		6RA7086-6KS22	40	720	552.0	828.0	528.0	792.0	518.0	1036.0	524.0	786.0
	6RA7088-6KS22	40	950	710.0	1065.0	686.0	1029.0	635.0	1270.0	667.0	1000.0	
	6RA7093-4KS22	40	1500	1150.0	1725.0	1110.0	1665.0	1050.0	2100.0	1100.0	1650.0	
	6RA7095-4KS22	40	2000	1590.0	2385.0	1520.0	2280.0	1510.0	3020.0	1504.0	2256.0	
830 V, 1Q	6RA7088-6LS22	40	900	664.0	996.0	642.0	963.0	595.0	1190.0	632.0	948.0	
	6RA7093-4LS22	40	1500	1150.0	1725.0	1110.0	1665.0	1040.0	2080.0	1100.0	1650.0	
	6RA7095-4LS22	40	1900	1486.0	2229.0	1420.0	2130.0	1400.0	2800.0	1412.0	2118.0	

SIMOREG 6RA70 DC MASTER

Planning Guide

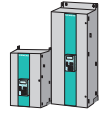

Dynamic overload capability

Load cycles for four-quadrant applications

Recommended SIMOREG DC Master	T_u	Load cycles									
		DC I		DC II		DC III		DC IV		US Rating $T_u = 45^\circ\text{C}$	
		Continu- ous	15 min 100%	60 s 150%	15 min 100%	120 s 150%	15 min 100%	10 s 200%	15 min 100%	60 s 150%	
Type	$^\circ\text{C}$	A	A	A	A	A	A	A	A	A	A
400 V, 4Q	6RA7013-6DV62	45	15	13.8	20.7	13.4	20.1	12.6	25.2	14.0	20.7
	6RA7018-6DV62	45	30	25.0	37.5	24.0	36.0	22.4	44.8	25.0	37.5
	6RA7025-6DV62	45	60	53.0	79.5	51.0	76.5	47.0	94.0	53.0	79.5
	6RA7028-6DV62	45	90	79.0	118.5	76.0	114.0	72.5	145.0	79.0	118.5
	6RA7031-6DV62	45	125	107.0	160.5	104.0	156.0	96.0	192.0	107.0	160.5
	6RA7075-6DV62	40	210	165.0	247.5	161.0	241.5	137.0	274.0	158.0	237.0
	6RA7078-6DV62	40	280	227.0	340.5	218.0	327.0	202	404.0	216.0	324.0
	6RA7081-6DV62	40	400	302.0	453.0	294.0	441.0	250.0	500.0	286.0	429.0
	6RA7085-6DV62	40	600	470.0	705.0	454.0	681.0	412.0	826.0	450.0	675.0
	6RA7087-6DV62	40	850	660.0	990.0	635.0	952.5	580.0	1160.0	628.0	942.0
	6RA7091-6DV62	40	1200	885.0	1327.5	858.0	1287.0	772.0	1544.0	850.0	1275.0
	6RA7093-4DV62	40	1600	1250.0	1875.0	1210.0	1815.0	1140.0	2280.0	1190.0	1785.0
	6RA7095-4DV62	40	2000	1480.0	2220.0	1435.0	2152.0	1332.0	2664.0	1402.0	2103.0
460 V, 4Q	6RA7018-6FV62	45	30	25.0	37.5	24.0	36.0	22.4	44.8	15.0	22.5
	6RA7025-6FV62	45	60	53.0	79.5	51.0	76.5	47.0	94.0	30.0	45.0
	6RA7028-6FV62	45	90	79.0	118.5	76.0	114.0	72.5	145.0	60.0	90.0
	6RA7031-6FV62	45	125	107.0	160.5	104.0	156.0	96.0	192.0	100.0	150.0
	6RA7075-6FV62	40	210	165.0	247.5	161.0	241.5	137.0	274.0	140.0	210.0
	6RA7078-6FV62	40	280	227.0	340.5	218.0	327.0	202.0	404.0	210.0	315.0
	6RA7082-6FV62	40	450	320.0	480.0	311.0	466.5	275.0	550.0	255.0	382.5
	6RA7085-6FV62	40	600	470.0	705.0	454.0	681.0	412.0	826.0	430.0	645.0
	6RA7087-6FV62	40	850	660.0	990.0	635.0	953.0	580.0	1160.0	510.0	765.0
	6RA7091-6FV62	40	1200	885.0	1327.5	858.0	1287.0	720.0	1544.0	850.0	1275.0
575 V, 4Q	6RA7025-6GV62	45	60	53.0	79.5	51.0	76.5	47.0	94.0	53.0	79.5
	6RA7031-6GV62	45	125	107.0	160.5	104.0	156.0	96.0	192.0	107.0	160.5
	6RA7075-6GV62	40	210	165.0	247.5	161.0	241.5	137.0	274.0	158.0	237.0
	6RA7081-6GV62	40	400	302.0	453.0	294.0	441.0	250.0	500.0	286.0	429.0
	6RA7085-6GV62	40	600	470.0	705.0	454.0	681.0	412.0	826.0	450.0	675.0
	6RA7087-6GV62	40	850	660.0	990.0	635.0	952.5	580.0	1160.0	628.0	942.0
	6RA7090-6GV62	40	1100	806.0	1209.0	782.0	1173.0	693.0	1386.0	765.0	1148.0
	6RA7093-4GV62	40	1600	1250.0	1875.0	1210.0	1815.0	1140.0	2280.0	1190.0	1785.0
	6RA7095-4GV62	40	2000	1660.0	2490.0	1590.0	2385.0	1570.0	3140.0	1660.0	2490.0
	690 V, 4Q	6RA7086-6KV62	40	760	600.0	900.0	576.0	864.0	536.0	1072.0	570.0
6RA7090-6KV62		40	1000	738.0	1107.0	716.0	1074.0	642.0	1284.0	702.0	1053.0
6RA7093-4KV62		40	1500	1160.0	1740.0	1130.0	1695.0	1040.0	2080.0	1110.0	1665.0
6RA7095-4KV62		40	2000	1480.0	2220.0	1435.0	2152.0	1332.0	2664.0	1402.0	2103.0
830 V, 4Q	6RA7088-6LV62	40	950	700.0	1050.0	680.0	1020.0	610.0	1220.0	667.0	1000.0
	6RA7093-4LV62	40	1500	1160.0	1740.0	1130.0	1695.0	1040.0	2080.0	1110.0	1665.0
	6RA7095-4LV62	40	1900	1486.0	2229.0	1420.0	2130.0	1400.0	2800.0	1412.0	2118.0

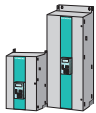

SIMOREG 6RA70 DC MASTER Planning Guide

Parallel connection

Parallel connection of SIMOREG DC MASTER converters

SIMOREG DC MASTER converters can be connected in parallel to increase their power output. The following boundary conditions must be met:

The terminal expansion option (CUD2) is required for each converter in the case of parallel connection. The terminal expansion contains the hardware and plug-in connectors required for transferring the firing pulses and the higher-level communication.

Up to 6 converters can be connected in parallel. When several converters are connected in parallel, the master unit must be located in the middle to reduce signal runtime. The maximum cable length for the parallel interface cable between the master and slave units at one end of the bus is 15 m.

Separate commutating reactors (u_k min. 2%) for the SIMOREG converters are needed for correct current distribution. The difference in tolerance between the reactors determines the current distribution. To avoid derating, a tolerance of 5% or more is recommended.

Important

Only converters with the same DC current rating may be connected in parallel!

Permissible output current for parallel connection on compliance with the boundary conditions:

$$I_{\max} = n \times I_{N(\text{SIMOREG})}$$

n = number of SIMOREG units

Redundancy mode ("n+1 duty")

Redundancy mode can be implemented as a special duty type for parallel connection of the SIMOREG DC MASTER converters. In this mode, if one converter fails (e.g. due to fuse rupture in the power section), operation can be maintained by means of the remaining SIMOREG units.

The fully functional SIMOREG units continue to operate without interruption when one unit has failed. At the planning stage, it must be ensured that the power output from only n units (instead of $n+1$ units) must be sufficient for the application.

This mode is possible in the event of slave unit failure as well as master unit failure.

Diagram showing the terminal connections for the parallel connection of SIMOREG units

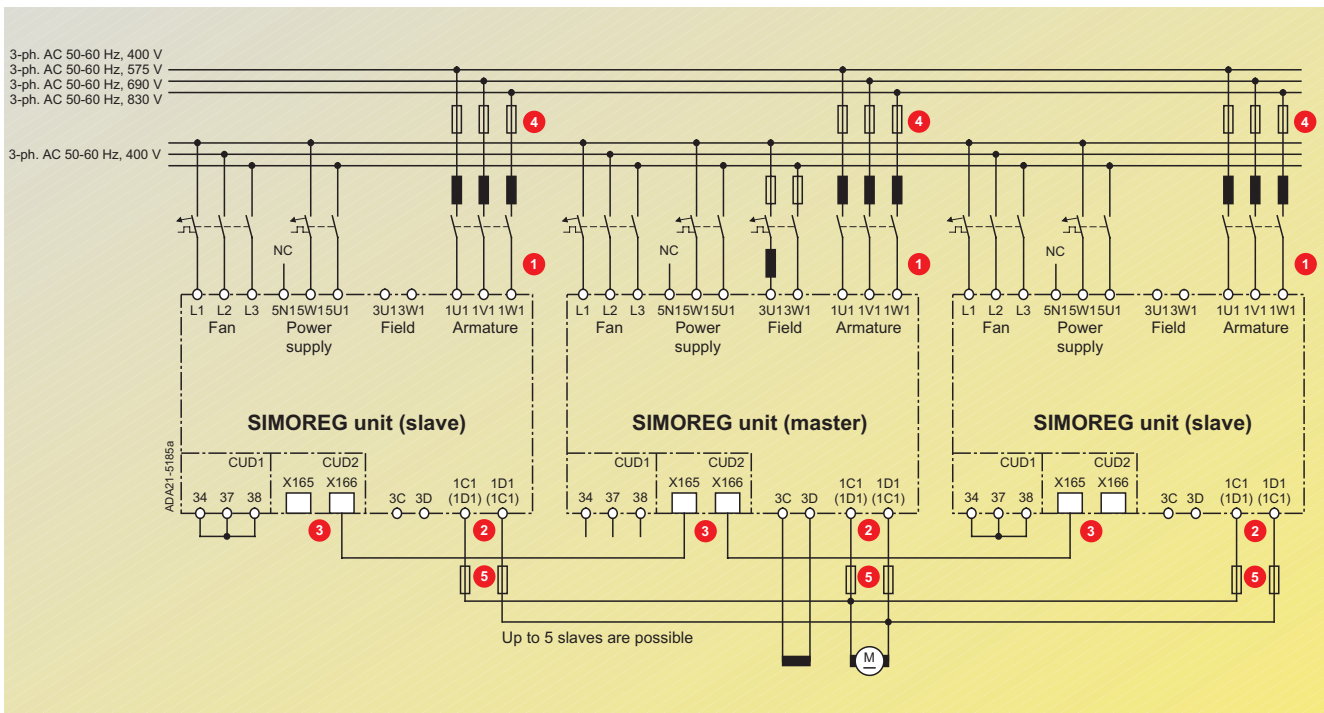

Fig. 5/32
Terminal connections for parallel connection

- ① It is essential that 1U1, 1V1 and 1W1 are in-phase.
- ② It is essential that 1C1 and 1D1 are in-phase.
- ③ The units are interconnected using (8-core) shielded patch cable UTP CAT5 acc. to ANSI/EIA/TIA 568 as used in PC network technology. A standard cable of 5 m in length can be ordered directly from Siemens

(Order No.: 6RY1707-0AA08).
To connect n units in parallel, $(n-1)$ cables will be required.
When a unit is connected to the start or end of the bus, the bus termination must be activated (U805=1).

- ④ These fuses are only to be inserted for units up to 850 A.

- ⑤ Only for units up to 850 A in 4Q mode.

SIMOREG 6RA70 DC MASTER

Planning Guide

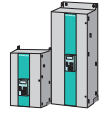

12-pulse operation, supplying high inductances, condensation protection

SIMOREG converters for 12-pulse operation

In 12-pulse operation, two SIMOREG converters are supplied with voltages displaced by 30 degrees, resulting in a reduction in harmonics. Each SIMOREG receives half the total current. One unit operates under speed control and the other operates under current control. Current setpoints are transferred from the first converter to the second via the peer-to-peer connection.

Smoothing reactors must be installed in the DC circuit for 12-pulse operation.

Calculation of smoothing reactor:

- One smoothing reactor is needed for each of the two converters. This is a twin-valve reactor, i.e. the reactor inductance is defined for two current values.

- The reactor is dimensioned thermally according to the rms value of the reactor DC current.

Calculation of required inductance: See Fig. 5/33.

Calculation of required inductance:

1. Inductance of reactor at $0.2 \times I_{dN}$ (L_{D1})
2. Inductance of reactor at I_{dmax} (L_{D2})

Inductance for 50 Hz line frequency:

$$L_{D1} = 0.296 \times 10^{-3} \times U_{di} / (0.2 \times I_{dN})$$

$$L_{D2} = 0.296 \times 10^{-3} \times U_{di} / (0.33 \times I_{dmax})$$

Inductance for 60 Hz line frequency:

$$L_{D1} = 0.24 \times 10^{-3} \times U_{di} / (0.2 \times I_{dN})$$

$$L_{D2} = 0.24 \times 10^{-3} \times U_{di} / (0.33 \times I_{dmax})$$

Legend:

L : Inductance in henry

I_{dN} : 50 % of rated DC current of DC motor

I_{dmax} : 50 % of maximum current of DC motor

$U_{di} = 1.35 \times U_N$

U_N : Rated voltage of supply system

Fig. 5/33
Calculation of required inductance

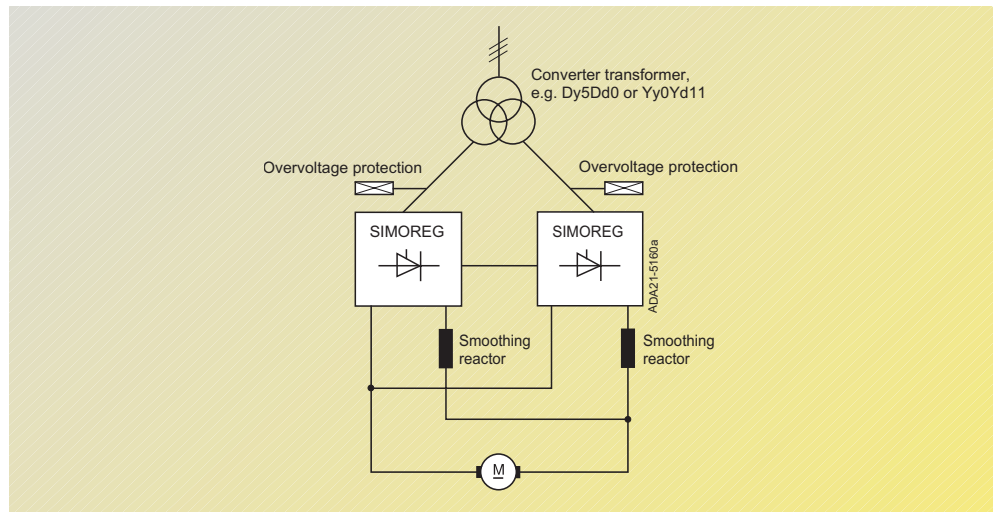

Fig. 5/34
12-pulse operation

5

SIMOREG for supplying high inductances

For supplying high inductances such as the fields of large DC or synchronous motors or solenoids, the gating unit is switched to long pulses via a parameter setting. Long pulses ensure reliable triggering of thyristors for high-inductance equipment. In such cases, the converter armature circuit (terminals 1C1/1D1) is not used to supply DC motors, but large-scale field windings.

Note

An external snubber circuit (e.g. resistor or block varistor) must be provided at the DC voltage output of the converter.

Condensation protection

SIMOREG converters are designed to comply with humidity class F without condensation.

Where converters are installed in tropical climates, it is advisable to install converter cubicle heating.

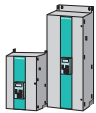

SIMOREG 6RA70 DC MASTER Planning Guide

Characteristic data of pulse evaluation electronics

Level of input pulses

The evaluation electronics are capable of processing encoder signals (both symmetrical and asymmetrical) up to a maximum of 27 V differential voltage. The evaluation electronics are electronically adapted (in Parameter P140) to the encoder signal voltage. The parameter setting selects one of two possible rated input voltages (see Table 4).

If the pulse encoder does not supply symmetrical encoder signals, then its grounding lead must be routed with each signal cable as a twisted pair and connected to the negative terminals of Track 1, Track 2 and the zero marker.

	Rated input voltage range	
	5 V P140 = 0x	15 V P140 = 1x
Low level	Differential voltage < 0.8 V	Differential voltage < 5 V
High level	Differential voltage > 2 V	Differential voltage > 8 V ¹⁾
Hysteresis	> 0.2 V	< 1 V
Common mode	± 10 V	± 10 V

Table 4
Explanation of terms

	Rated input voltage range				
	5 V		15 V		
Differential voltage ²⁾	2 V	> 2.5 V	8 V	10 V	> 14 V
T_{min} ³⁾	630 ns	380 ns	630 ns	430 ns	380 ns

Table 5
Minimum distance between edges

	f_{max}				
	50 kHz	100 kHz	150 kHz	200 kHz	300 kHz
Differential voltage ⁴⁾	to 27 V	to 22 V	to 18 V	to 16 V	to 14 V

Table 6
Maximum input frequency as a function of supply voltage

Switching frequency

The maximum frequency of the encoder pulses is 300 kHz. To ensure correct evaluation of the encoder pulses, the minimum distance T_{min} between two encoder signal edges (Tracks 1 and 2) specified in the table must be observed (see Table 5).

If the pulse encoder is incorrectly matched to the encoder cable, disturbing cable reflections will be produced at the receive end. These reflections must be damped so that the encoder pulses can be correctly evaluated. The limit values specified in Table 6 must be maintained to ensure that the resultant power loss in the adapting element of the evaluation electronics is not exceeded.

Cable, cable length, shield connection

The encoder cable capacitance must be recharged at each encoder edge change. The rms value of this current is proportional to the cable length and pulse frequency and must not exceed the current specified by the encoder manufacturer. A suitable cable as recommended by the encoder manufacturer must be used and the maximum cable length must not be exceeded.

Generally, a twisted-pair cable with a common pair shield is sufficient for each track. Crosstalk between the cables is thus reduced. The shielding of all pairs protects against noise pulses. The shield must be connected to the shield bar of the SIMOREG converter over the largest possible surface area.

5

1) Restriction: See switching frequency

2) Differential voltage at evaluation electronics terminals

3) The phase error L_G (deviation from 90°), which may occur as the result of encoder and cable, can be calculated from T_{min} :

$$L_G = + (90^\circ - f_p \times T_{min} \times 360^\circ \times 10^{-6})$$

L_G [°] = Phase error
 f_p [kHz] = Pulse frequency
 T_{min} [ns] = Minimum distance between edges

4) Differential voltage of encoder pulses without load (approximate encoder current supply voltage)

SIMOREG 6RA70 DC MASTER Planning Guide

Instructions for the electromagnetically compatible installation of drives



Fundamentals of EMC

What is EMC

EMC stands for “electromagnetic compatibility”; it describes the capability of a device to operate satisfactorily in the electromagnetic environment, without causing electromagnetic interference which is unacceptable for other devices in this environment. In other words, the different devices must not interfere with each other.

Emitted interference and interference immunity

EMC depends on two characteristics of the devices involved: emitted interference and interference immunity. Electrical devices can be interference sources (transmitters) and/or interference sinks (receivers).

Electromagnetic compatibility exists when the interference sources do not affect functioning of the interference sinks.

A device can be simultaneously an interference source and sink. For example, the power section of a converter can be considered as an interference source and the control section as an interference sink.

Limit values

Product standard EN 61800-3 (IEC 1800-3, DIN VDE 160 Part 100) covers electrical drives. According to this product standard, not all EMC measures are essential for industrial supply systems; a solution must be defined which is adapted to the actual environment. This it may be economically more advantageous to increase the interference immunity of a sensitive device rather than implement interference suppression on the converter. The choice of solution, therefore, also depends on economic factors.

To some extent, adherence to EN 55011 is required. This defines the limit values for emitted interference in industry and in residential buildings. Conducted interference at the supply connection is measured under standardized conditions as a radio interference voltage and electromagnetically emitted interference is measured as interference emission. The standard defines limit values “A1” and “B1” which apply to radio interference voltage over the range 150 kHz and 30 MHz and to interference emission over the range 30 MHz to 2 GHz. Since the SIMOREG K converters are used in industry, limit value “A1” applies. To achieve limit value “A1”, the SIMOREG K units must be provided with external RFI filters.

Interference immunity describes the behavior of a device under the influence of electromagnetic interference. Standard EN 50082-2 governs the requirements and assessment criteria for the behavior of the devices in industry. This standard is met by the converters listed in the following Section.

Application in industry

In industry, the interference immunity of the devices must be very high, whilst lower demands are made on emitted interference.

The SIMOREG converters are components of an electrical drive, as are contactors and switches. Skilled personnel must integrate them in a drive system comprising at least the converter, motor cables and the motor. Commutating reactors and fuses are usually also needed.

Proper installation thus also determines whether or not a limit value will be met. To limit the emitted interference according to limit value “A1”, at least the corresponding radio interference suppression filter and the commutating reactor are also needed in addition to the converter. Without a radio interference suppression filter, the emitted interference of the SIMOREG converters exceeds limit value “A1” of EN 55011.

If the drive is part of an installation, it need not initially meet requirements relating to emitted interference. However, the EMC legislation requires that the entire installation be electromagnetically compatible with the environment.

If all the control components of the installation, such as automation equipment, exhibit industrial grade interference immunity, there is no need for each drive to satisfy limit value “A1”.

Ungrounded supply systems

In some branches of industry, ungrounded supply systems (IT systems) are used to increase availability of the plant. In the event of a ground fault, there is no ground current and the plant can continue with production. In conjunction with radio interference suppression filters, however, there is a fault current in the event of a ground fault which can result in a shutdown of the drives or even the destruction of the filter. The product standard therefore does not specify limit values for these systems. For economic reasons, interference suppression, if required, should be implemented on the grounded primary side of the supply transformer.

EMC planning

If two devices are electromagnetically incompatible, you can reduce the emitted interference of the source or increase the interference immunity of the sink.

Interference sources are usually power electronics devices with a high current consumption. To reduce their emitted interference, elaborate filters are required. Interference sinks are, in particular, control units and sensors including their evaluation circuits. Enhancing the interference immunity of low-power devices is less involved. For economical reasons in industry, therefore, it is often more favorable to increase the interference immunity than to reduce emitted interference. To satisfy limit value class A1 of EN 55011, for example, the radio interference voltage at the supply terminals must not exceed 79 dB (μV) between 150 and 500 kHz, and 73 dB (μV) (9 mV or 4.5 mV) between 500 kHz and 30 MHz.

In industry, the EMC of equipment should be based on a judicious balance between emitted interference and interference immunity.

The least expensive suppression method is to separate the interference sources and sinks, provided that this is taken into account during the planning of a machine/plant. For each device used, the first question is whether it is a potential interference source or sink. Examples of interference sources in this context are converters and contactors. Examples of interference sinks are programmable controllers, encoders and sensors.

The components in the cabinet (interference sources and sinks) should be separated, if necessary with partition plates or by installing them in metal housings. Fig. 5/35 shows a possible arrangement of components in the cabinet.

5

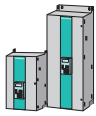

SIMOREG 6RA70 DC MASTER Planning Guide

Instructions for the electromagnetically compatible installation of drives

Electromagnetically compatible installation of drives

General notes

Since the drives are operated in very different environments and additional electrical components (controllers, switched-mode power supplies, etc.) can differ greatly with regard to interference immunity and emitted interference, each installation guideline can only be a sensible compromise. In individual cases, therefore, after examination, deviation from the rules is possible.

To ensure electromagnetic compatibility (EMC) in your cabinets in an electrically harsh environment and to be able to meet the legal standards, the following EMC rules should be observed during design and installation.

Rules 1 to 10 are generally applicable. Rules 11 to 15 are necessary to meet the emitted interference standards.

Rules for electromagnetically compatible installation

Rule 1

All metal parts of the cabinet must be joined to each other with good electrical contact (not paintwork on paintwork!). Contact or toothed washers should be used where necessary. The cabinet door should be connected to the cabinet via ground straps (at top, middle and bottom) with as short a path as possible.

Rule 2

Contactors, relays, solenoid valves, electromagnetic operating hours counters, etc. in the cabinet and if necessary in adjacent cabinets, should be provided with suppression combinations, such as RC networks, varistors or diodes. The circuitry must be implemented directly at the particular coil.

Rule 3

Signal lines ¹⁾ should be routed into the cabinet from one level if possible.

Rule 4

Unshielded conductors of the same circuit (outgoing and return conductors) should be twisted together if possible, i.e. the surface between outgoing and return conductors should be kept as small as possible to prevent the creating of unnecessary frame antennas.

Rule 5

Spare cores should be connected to the cabinet ground ²⁾. This achieves additional shielding.

Rule 6

Unnecessary line lengths should be avoided. Coupling capacitances and inductances are thus kept low.

Rule 7

In general, crosstalk is reduced when conductors are placed close to the cabinet ground. Wiring should, therefore not be placed in free space in the cabinet but, wherever possible, routed closely along the cabinet housing or installation plates. This also applies to spare cables.

Rule 8

Signal lines and power cables should be laid separately from each other (to avoid coupling paths). A minimum clearance of 20 cm is desirable.

If segregation between sensor cables and motor cables is not possible, the sensor cable should be decoupled by a partition plate or by installing it in a metal conduit. The partition plate or metal conduit should be grounded at several points.

Rule 9

The shields of digital signal cables should have good large-area electrical grounding at each end (source and destination). In the event of poor equipotential bonding between the shield connections, an additional equalizing conductor of at least 10 mm² should be laid in parallel with the shield to reduce the shield current. In general, shields may be connected to the cabinet housing (ground) at several points. Even outside the cabinet, the shields may be connected in several places.

Foil shields are not satisfactory. Compared to braid shields, their shielding effect is inferior by a factor of at least 5.

Rule 10

With good equipotential bonding, the shields of analog signal lines may be grounded at both ends (with good large-area contact!). Good equipotential bonding can be assumed if all metal parts make good contact and the electronic components involved are powered from the same power supply.

Single-ended shield grounding prevents low-frequency capacitive interference pickup such as 50 Hz hum. The shield connection should be made in the cabinet; a sheath wire may be used to connect the shield.

Rule 11

Positioning the radio interference suppression filter in the vicinity of the suspected interference source: The filter should be mounted with its surface on the cabinet housing, mounting plate, etc.. Input and output leads should be separated.

Rule 12

The use of radio interference suppression filters is mandatory for compliance with limit value class A1. Additional loads should be connected ahead of the filter (supply system side).

The need to install an additional line filter depends on the controller in use and on the type of wiring of the rest of the cabinet.

Rule 13

With a regulated field current supply, a commutating reactor is needed in the field circuit.

Rule 14

A commutating reactor is needed in the armature circuit of the converter.

Rule 15

With SIMOREG drives, the motor cables may be unshielded. The supply cable must have a clearance of at least 20 cm from the motor cables (field, armature). A partition plate should be used if necessary.

1) Signal lines are defined as:
Digital signal line:
Lines for pulse generators
Serial interfaces, e.g. PROFIBUS-DP
or analog signal line
(e.g. ±10 V setpoint line).

2) The definition of ground, in general, encompasses all metallic conductive parts which can be connected to a protective conductor, e.g. a cabinet housing, motor housing, foundations earth, etc.

SIMOREG 6RA70 DC MASTER

Planning Guide

Instructions for the electromagnetically compatible installation of drives

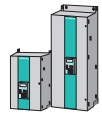

Cabinet arrangement and shielding

The cabinet arrangement of Fig. 5/35 is intended to draw the user's attention to the EMC-critical parts. The example does not necessarily show all possible cabinet components or arrangements.

Details affecting the interference immunity and emitted interference of the cabinet and which do not clearly appear in the block diagram are shown in Figs. 5/36 and 5/37.

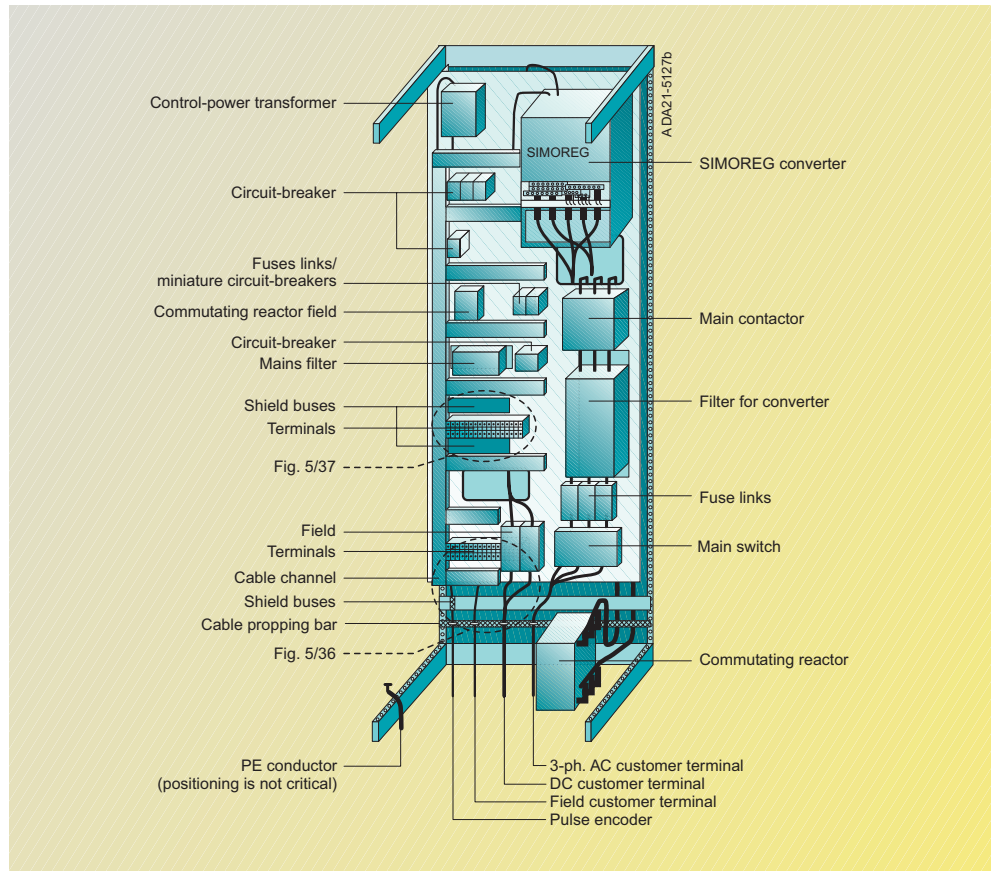

Fig. 5/35
Example of cabinet arrangement with a SIMOREG converter

5

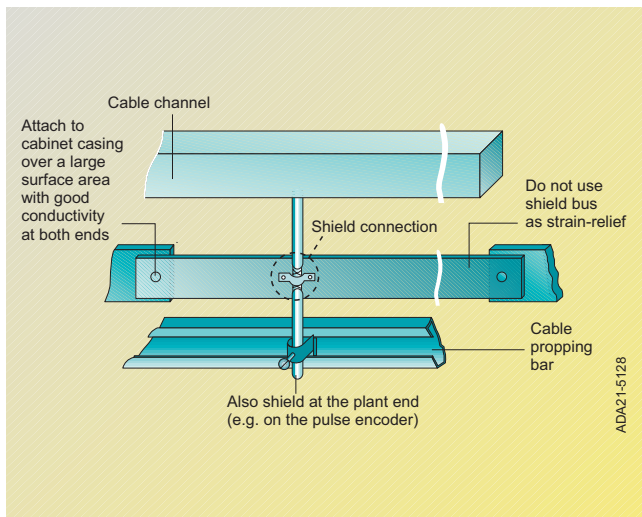

Fig. 5/36
Shielding with routing into the cabinet

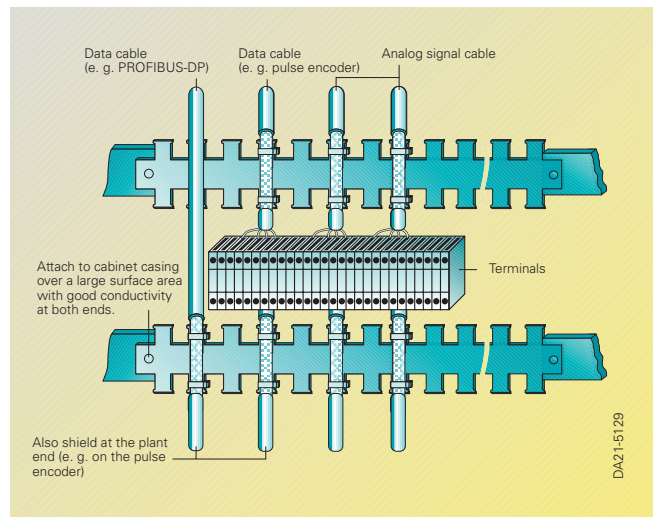
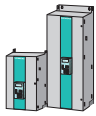

Fig. 5/37
Shielding in the cabinet



Components for the converters

The arrangement of radio interference suppression filters and commutating reactors for SIMOREG DC MASTER converters is shown in the Figure below. The reactors and filters must be installed in the specified order.

Caution

When filters are used, commutating reactors are always needed between the filter and the input of the unit to decouple the RC circuit.

For selection of the commutating reactors, see Page 5/24.
For selection of the radio interference suppression filters, see Catalog DA 93.1.

Line fuses

The SITOR dual protection fuse 3NE1 provides both lead and semiconductor protection in a single fuse. This reduces costs considerably and also reduces the installation time.

For the Order No. and assignments, see Section 7. For a description of the fuses and their technical data, see Catalog DA 94.1, Order No.: E20002-K4094-A111-A3.

- 1 The commutating reactor in the field circuit is designed for the rated current of the motor field.
- 2 The commutating reactor in the armature circuit is designed for the rated motor current in the armature. The supply current is equal to the DC multiplied by 0.82.
- 3 The radio interference suppression filter for the electronics power supply alone at 400 V is designed for ≥ 1 A. The filter for the field circuit and the electronics power supply at 400 V is designed for the rated current of the motor field plus 1 A.
- 4 The filter for the armature circuit is designed for the rated motor current in the armature. The supply current is equal to the DC multiplied by 0.82.
- 5 The radio interference suppression filter for the electronics power supply at 230 V is designed for ≥ 2 A.

Line commutating reactors

A converter must always be connected to the supply via a commutating inductance. This must be at least 4% u_k ! The commutating inductance can be implemented as a converter transformer or, with appropriate mains voltage, as a commutating reactor.

A supply can be regarded as "constant" when the output ratio $P_g/S_k \leq 0.01$. Even in the case of a constant supply, the commutating reactor must have a u_k of at least 4% !

For high-power converters, the supply reactance, i.e. the total short-circuit power of the supply must be taken into account, which also results in a larger u_k value. The recommended ratio of supply short-circuit power to apparent drive power is $> 33:1$.

The commutating reactors are dimensioned for the rated motor current in the armature or field circuit.

For the recommended commutating reactors, see Page 5/24.

Operation on a 50 Hz and 60 Hz supply

The rated currents I_{LN} specified in the Table for the reactors apply for operation at a supply frequency $f = 50$ Hz. Operation of the reactors at a supply frequency $f = 60$ Hz is permissible. In this case, the permissible rated current I_{LN} is reduced to 90%.

$$I_{LN}(60 \text{ Hz}) = 0.9 \cdot I_{LN}(50 \text{ Hz})$$

At the same time, the voltage drop ΔU increases by 8%.

For further details, see Catalog DA 93.1.

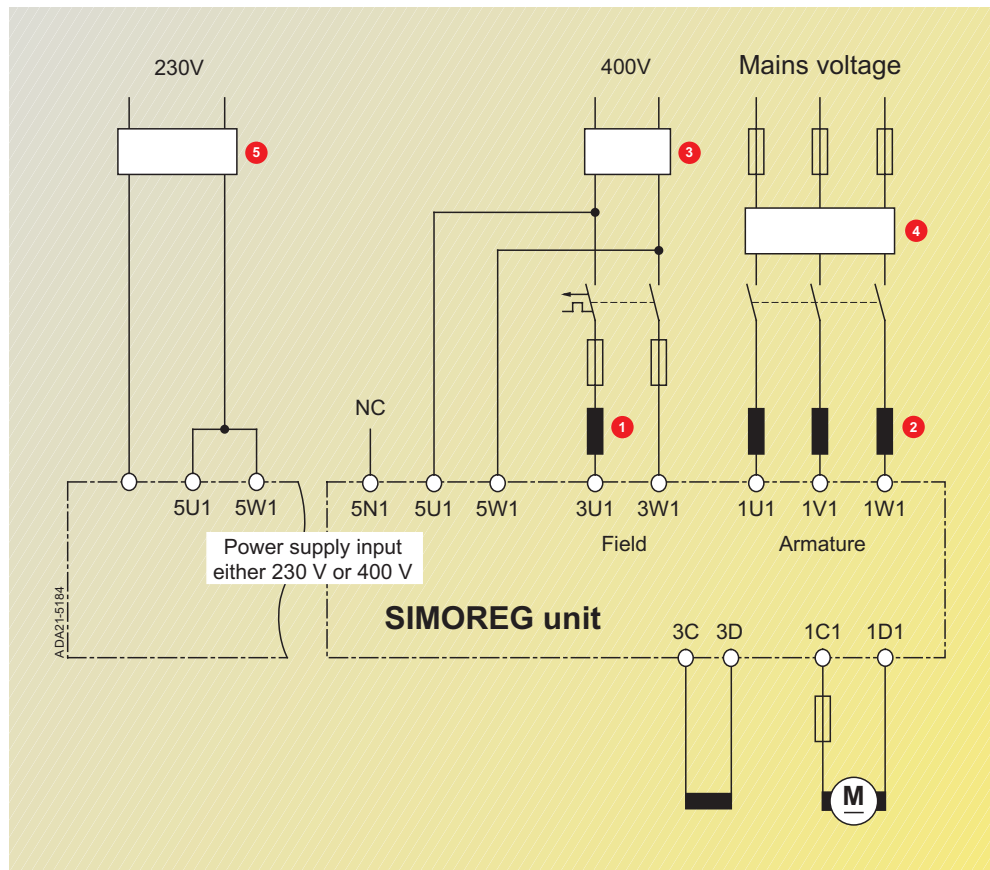
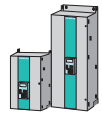

Fig. 5/38
Arrangement of the reactors and radio interference suppression filters

SIMOREG 6RA70 DC MASTER

Planning Guide



Components

Commutating reactors

Rated AC current I_{Ln} A	Max. AC current I_{Lmax} A	Permissible continuous DC current $I_{dn}^{3)}$ A	Referred voltage drop u_D of the reactor at I_{Lmax} and U_N			
			Order No.: 400 V	Order No.: 500 V	Order No.: 690 V	Order No.: 750 V

Single-phase commutating reactors $I_{Ln} = I_{Lmax}$ with inductive load

8	8	9.8	4EM48 07-1CB	-	-	-
10	10	12.3	4EM49 11-7CB	-	-	-
11.2	11.2	13.7	4EM49 11-8CB	-	-	-
12.5	12.5	15.3	4EM49 12-0CB	-	-	-
14	14	17.2	4EM49 12-1CB	-	-	-
15	15	18.4	4EM50 00-2CB	-	-	-
18	18	22	4EM50 05-6CB	-	-	-
20	20	24.5	4EM50 05-7CB	-	-	-
22.4	22.4	27.4	4EM50 05-8CB	-	-	-
24	24	29.4	4EM51 00-2CB	-	-	-
28	28	34	4EM61 00-2CB	-	-	-
31.5	31.5	39	4EM61 00-3CB	-	-	-
35.5	35.5	43	4EM52 12-8CB	-	-	-
40	40	49	4EM52 00-1CB	-	-	-
45	45	55	4EM62 00-3CB	-	-	-
50	50	61	4EM53 16-6CB	-	-	-

Three phase commutating reactors $I_{Ln} = 0.8 \cdot I_{Lmax}$ with inductive load 3-ph. AC 50 Hz

16	20	19.6	4EP36 01-3DS	4EP36 01-8DS	-	-
18	22.4	22	4EP36 01-4DS	4EP36 02-0DS	-	-
20	25	24.5	4EP36 01-5DS	4EP37 02-0DS	-	-
22.4	28	27.4	-	4EP37 02-1DS	-	-
25	31.5	31	4EP37 01-5DS	4EP37 02-2DS	-	-
28	35.5	34	4EP37 01-6DS	4EP38 01-7DS	-	-
31.5	40	39	4EP37 01-7DS	4EP38 01-8DS	-	-
35.5	45	43	4EP37 01-8DS	4EP38 02-0DS	-	-
40	50	49	4EP38 00-2DS	4EP38 00-4DS	-	-
45	56	55	4EP38 01-6DS	4EP39 01-5DS	-	-
50	63	61	4EP38 00-3DS	4EP39 00-3DS	-	-
56	71	69	4EP39 01-4DS	4EP40 03-1DS	-	-
63	80	77	4EP39 00-2DS	4EP40 00-4DS	-	-
71	91	87	4EP40 02-7DS	4EP40 03-2DS	-	-
80	100	98	4EP40 00-3DS	4EU24 22-8AA00-0A	-	-
91	112	112	4EP40 02-8DS	4EU24 22-0BA00-0A	-	-
100	125	123	4EP40 03-0DS	4EU25 22-6BA00-0A	-	-
112	140	137	4EU24 22-6AA00-0A	4EU25 22-7BA00-0A	-	-
125	160	153	4EU24 22-7AA00-0A	4EU25 22-8BA00-0A	-	-
140	180	172	4EU25 22-2BA00-0A	4EU25 22-0CA00-0A	-	-
160	200	196	4EU25 22-3BA00-0A	4EU27 22-0CA00-0A	-	-
180	224	221	4EU25 22-4BA00-0A	4EU27 22-1CA00-0A	-	-
200	250	245	4EU25 22-5BA00-0A	4EU27 22-2CA00-0A	4EU27 22-0DA00-0A	-
224	280	275	4EU27 22-5BA00-0A	4EU27 22-3CA00-0A	4EU30 22-8BA00-0A	-
250	315	306	4EU27 22-6BA00-0A	4EU27 22-4CA00-0A	4EU30 22-0CA00-0A	4EU30 22-2CA00-0A
280	355	343	4EU27 22-7BA00-0A	4EU30 22-5BA00-0A	4EU30 22-1CA00-0A	4EU36 22-5DA00-0A
315	400	386	4EU27 22-8BA00-0A	4EU30 22-6BA00-0A	4EU36 22-0DA00-0A	4EU36 22-6DA00-0A
355	450	435	4EU30 22-1BA00-0A	4EU30 22-7BA00-0A	4EU36 22-1DA00-0A	4EU36 22-7DA00-0A
400	500	490	4EU30 22-2BA00-0A	4EU36 22-4CA00-0A	4EU36 22-2DA00-0A	4EU36 22-8DA00-1B
450	560	551	4EU30 22-3BA00-0A	4EU36 22-5CA00-0A	4EU36 22-3DA00-0A	4EU36 22-0EA00-1B
500	630	613	4EU30 22-4BA00-0A	4EU36 22-6CA00-0A	4EU36 22-4DA00-0A	4EU39 21-1CA00
560	710	686	4EU36 22-0CA00-0A	4EU36 22-7CA00-0A	4EU39 21-8BA00	4EU39 21-2CA00
630	800	772	4EU36 22-1CA00-0A	4EU36 22-8CA00-1B	4EU39 21-0CA00	4EU43 21-4DA00
710	910	870	4EU36 22-2CA00-0A	4EU39 21-6BA00	4EU43 21-0DA00	4EU43 21-5DA00
800	1000	980	4EU36 22-3CA00-1B	4EU39 21-7BA00	4EU43 21-1DA00	4EU43 21-6DA00
910	1120	1115	4EU39 21-2BA00	4EU43 21-4CA00	4EU43 21-2DA00	4EU45 21-4BA00
980	1230	1200	-	-	4EU43 21-0AY00	-
1000	1250	1225	4EU39 21-3BA00	4EU43 21-5CA00	4EU43 21-3DA00	4EU45 21-5BA00
1040	1300	1280	4EU39 21-0AL00	4EU43 21-0AX00 ²⁾	-	-
1310	1640	1600	4EU43 21-0AW00	4EU45 21-0AK00 ²⁾	4EU45 21-0AP00	-

1) All reactors with $U_N \leq 600$ V acc. to UL

2) Referred voltage drop of the reactor $u_D \sim 4\%$ at I_{Ln} and $U_N = 575$ V

3) With series-connected 6-pulse bridge circuit

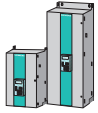

SIMOREG 6RA70 DC MASTER Planning Guide

Components

Radio interference suppression filters

SIMOREG DC MASTER applications comply with the EMC product standard EN 61 800-3 for electrical drives provided that the rules for electromagnetically compatible installation of the converters in the plant are observed.

However, the EMC legislation requires that the entire installation be electromagnetically compatible with the environment.

If the system is to comply with the "A1" degree of radio interference suppression according to EN 55011, RI suppression filters must be installed in addition to commutating reactors. In conjunction with the commutating reactors, the RI suppression filters reduce the radio interference voltages that arise due to the converters. RI suppression filters can only be installed in grounded-neutral systems.

The RI suppression filters generate discharge currents. In accordance with DIN VDE 0160, a PE connection with a cross-sectional area of 10 mm² is necessary. To ensure the best possible action of the filter it must be mounted with the converter on a common metal plate.

For converters with a three-phase system, the minimum rated current

of the filter is equal to the output DC current multiplied by 0.82. For units with a two-phase system (field supply and electronics power supply), only two phases are connected to the three-phase RI suppression filter. The line current is equal to the field DC current (plus 1 A for the electronics power supply).

List of suggested RI suppression filters from EPCOS

*) In place of *, the identification number for the design type must be inserted:
0 = 480 V
2 = 530 V

**) In place of **, the identification number for the design type must be inserted:
20 = 500 V
21 = 760 V
24 = 690 V

For further information about filters, visit www4.ad.siemens.de. Please enter 65 67 129 under "Article number".

Rated current Radio interference suppression filters A	Radio interference suppression filters Type	Terminal cross-section mm ² Holes for M . .	Weight approx. kg	Dimensions H x W x D mm x mm x mm
8	B84143-G8-R11*	4 mm ²	1.3	80 x 230 x 50
20	B84143-G20-R11*	4 mm ²	1.3	80 x 230 x 50
36	B84143-G36-R11*	6 mm ²	2.8	150 x 280 x 60
50	B84143-G50-R11*	16 mm ²	3.3	150 x 60 x 330
66	B84143-G66-R11*	25 mm ²	4.4	150 x 330 x 80
90	B84143-G90-R11*	25 mm ²	4.9	150 x 330 x 80
120	B84143-G120-R11*	50 mm ²	7.5	200 x 380 x 90
150	B84143-G150-R11*	50 mm ²	8.0	200 x 380 x 90
220	B84143-G220-R11*	95 mm ²	11.5	220 x 430 x 110
150	B84143-B150-S**	M10	13	140 x 310 x 170
180	B84143-B180-S**	M10	13	140 x 310 x 170
250	B84143-B250-S**	M10	15	115 x 360 x 190
320	B84143-B320-S**	M10	21	115 x 360 x 260
400	B84143-B400-S**	M10	21	115 x 360 x 260
600	B84143-B600-S**	M10	22	115 x 410 x 260
1000	B84143-B1000-S**	M12	28	165 x 420 x 300
1600	B84143-B1600-S**	2 x M12	34	165 x 550 x 300
2500	B84143-B2500-S**	4 x M12	105	200 x 810 x 385

List of suggested RI suppression filters from Siemens

Rated current Radio interference suppression filters A	Radio interference suppression filters Type	Terminal cross-section mm ²	Ground bolt	Weight approx. kg	Dimensions H x W x D mm x mm x mm
12	6SE7021-0ES87-0FB1	4	M6	2.5	215 x 90 x 81
18	6SE7021-8ES87-0FB1	4	M6	2.5	215 x 90 x 81
36	6SE7023-4ES87-0FB1	16	M6	4	231 x 101 x 86
80	6SE7027-2ES87-0FB1	50	M10	9	308 x 141 x 141
120	6SE7031-2ES87-0FA1	50	M10	10	348 x 171 x 141
180	6SE7031-8ES87-0FA0	95	M10	10	404 x 171 x 141
320	6SE7033-2ES87-0FA1	Terminal link	M10 x 30	21	300 x 260 x 116
600	6SE7036-0ES87-0FA1	Terminal link	M10 x 30	22	350 x 260 x 116
1000	6SE7041-0ES87-0FA1	Terminal link	M10 x 30	28	350 x 300 x 166
1600	6SE7041-6ES87-0FB1	Terminal link	M12 x 30	34	400 x 300 x 166

Technical Data

Rated supply voltage	3-ph. AC 380-460 V (±15%)
Rated frequency	50/60 Hz (±6%)
Operating temperature	0 to +40°C
Degree of protection	IP 20 (EN 60529); IP 00 from 500 A

SIMOREG 6RA70 DC MASTER

Planning Guide

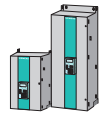

Harmonics

Supply harmonics of converters in fully controlled, three-phase bridge connections B6C and (B6)A(B6)C

Converters for medium power are mainly designed in fully controlled three-phase bridge connection. An example of harmonics of a typical installed configuration for two delay angles ($\alpha = 20^\circ$ and $\alpha = 60^\circ$) are shown below.

The values have been adopted from a previous publication: "Oberschwingungen im netzseitigen Strom sechspulsiger netzgeführter Stromrichter" (Harmonics in the supply current of six-pulse line-commutated converters) by H. Arremann and G. Möltgen, Siemens Forschungs- und Entwicklungsberichte, Vol. 7 (1978) No. 2, © Springer-Verlag 1978.

This is accompanied by formulas with which, depending on the operating data in the specific case, supply voltage (no-load voltage U_{V0}), line frequency f_N and DC current I_d , the short-circuit power S_K and armature inductance L_a of the motor are determined, and to which the specified harmonic spectrum applies.

The given harmonic spectrum is attained when the values calculated with the following formulas for short-circuit power S_K at the connection point of the unit and the armature inductance L_a of the motor coincide with the actual values of the installation. If the values differ, a separate calculation of harmonics is necessary.

If the actual system short-circuit power and/or the actual armature inductance deviate from the values thus calculated, an individual calculation is necessary.

a) $\alpha = 20^\circ$
Fundamental factor $g = 0,962$

v	I_v/I_1	v	I_v/I_1
5	0.235	29	0.018
7	0.100	31	0.016
11	0.083	35	0.011
13	0.056	37	0.010
17	0.046	41	0.006
19	0.035	43	0.006
23	0.028	47	0.003
25	0.024	49	0.003

b) $\alpha = 60^\circ$
Fundamental factor $g = 0.953$

v	I_v/I_1	v	I_v/I_1
5	0.283	29	0.026
7	0.050	31	0.019
11	0.089	35	0.020
13	0.038	37	0.016
17	0.050	41	0.016
19	0.029	43	0.013
23	0.034	47	0.013
25	0.023	49	0.011

The fundamental current I_1 as the reference quantity is calculated with the following formula:

$$I_1 = g \times 0.817 \times I_d$$

where I_d = DC of the examined operating point and g = fundamental factor (see above)

The harmonic currents calculated from the above tables apply only to

a) Short-circuit power S_K at the connection point of the converter:

$$S_K = \frac{U_{V0}^2}{X_N} \text{ (VA)}$$

where

$$X_N = X_K - X_D = 0,03536 \times \frac{U_{V0}}{I_d} - 2\pi f_N \times L_D \text{ (}\Omega\text{)} \text{ und}$$

U_{V0} No-load voltage at the connection point of the converter in V

I_d DC current for the examined operating point in A

f_N Line frequency in Hz

L_D Inductance of the commutating choke in H.

b) Armature inductance L_a :

$$L_a = 0,0488 \times \frac{U_{V0}}{f_N \times I_d} \text{ (H)}$$

If the actual values of short-circuit power S_K and/or armature inductance L_a differ from the values calculated using the above formulas, a separate calculation is necessary.

Example:

The given drive has the following data:

$$U_{V0} = 400 \text{ V}$$

$$I_d = 150 \text{ A}$$

$$f_N = 50 \text{ Hz}$$

$$L_D = 0.169 \text{ mH (4EU2421-7AA10 with } I_{LN} = 125 \text{ A)}$$

where

$$X_N = 0.03536 \times \frac{400}{150} - 2\pi \times 0.169 \times 10^{-3} = 0.0412 \Omega$$

resulting in the following required short-circuit power of the system at the connection point of the converter:

$$S_K = \frac{400^2}{0,0412} = 3.88 \text{ MVA}$$

and the following required armature inductance of the motor:

$$L_a = 0.0488 \times \frac{400}{50 \times 150} = 2.0 \text{ mH}$$

The harmonic currents listed in the tables I_v (where $I_1 = g \times 0.817 \times I_d$ for delay angle $\alpha = 20^\circ$ and $\alpha = 60^\circ$) apply only to the values S_K and L_a . If the values differ, a separate calculation is necessary.

When designing filters and reactor compensations, the harmonic values thus calculated can only serve as a basis if the calculated values for S_K and L_a coincide with the actual values of the drive. In all other cases a separate calculation must be made (especially when compensated machines are used because of the very low armature inductance).



SIMOREG 6RA70 DC MASTER SIMOREG CM



6/2	Application
6/2	Design
6/3	Technical Data
6/3	Standards
6/4	Block diagram
6/6	Options

SIMOREG 6RA70 DC MASTER SIMOREG CM

Application



Fig. 6/1
SIMOREG CM

An important application for the SIMOREG CM converter is in the retrofitting and modernization of DC drives in existing systems.

In the field of DC drives, many systems exist that are older than 5 or 10 years and that still use analog technology.

On retrofitting or updating these systems, the motor, mechanical components and power section are retained and only the closed-loop control section is replaced by a 6RA70 Control Module. This is an extremely economical way to obtain a modern DC drive with the complete functional scope of the well-proven, fully digital converters of the SIMOREG DC MASTER series.

It is easily adapted to the configuration of the existing components by setting parameters.

The 6RA70 Control Module contains a power section for supplying the field with a rated current of up to 40 A.

Design

The 6RA70 Control Module is characterized by its compact, space-saving design. The compact construction makes it especially easy to service since individual components are easily accessible. The electronics box contains the basic electronics as well as any supplementary boards.

To support optimum utilization of the installation possibilities in the system, the 6RA70 Control Module can be separated in its depth. Furthermore, the PCBs for firing pulse generation and distribution as well as for fuse monitoring and voltage measurement are designed to be removed and mounted either partially or completely outside the unit directly on the power section and connected to the basic unit via cables.

All 6RA70 Control Modules are equipped with a PMU simple operator panel in the door of the unit. The PMU consists of a five-digit, seven-segment display, three LEDs as status indicators and three parameterization keys. The PMU also features connector X300 with a USS interface in compliance with the RS232 or RS485 standard.

The panel provides all the facilities required during start-up for making adjustments or settings and displaying measured values.

The optional OP1S converter operator panel can be mounted either in the converter door or externally, e.g. in the cubicle door. For this purpose, it can be connected up by means of a 5 m long cable. Cables of up to 200 m in length can be used if a separate 5 V supply is available. The OP1S is connected to the SIMOREG CM unit via connector X300.

The OP1S can be installed as an economic alternative to control cubicle measuring instruments which display physical measured quantities.

The OP1S features an LCD with 4 x 16 characters for displaying parameter names in plain text. English, German, French, Spanish and Italian can be selected as the display languages.

The OP1S can store parameter sets for easy downloading to other devices.

The converter can also be parameterized via the serial interface of the basic unit by means of a generally available PC and appropriate software. This PC interface is used for start-up, for maintenance during shutdown and for diagnosis during operation and is, therefore, a service interface. Upgrades of the converter software that is stored in Flash memory can also be loaded via this interface.

The field is supplied by a single-phase, semi-controlled dual pulse bridge connection B2HZ. The power section for the field is constructed with galvanically isolated thyristor modules; the heat sink is therefore at floating potential.

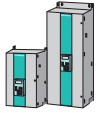

SIMOREG 6RA70 DC MASTER SIMOREG CM

Technical data

Type 6RA7000-0MV62-0

Measurable rated supply voltage armature	V	85 / 250 / 575 / 1000
Rated supply voltage electronics supply	V	2-ph. AC 380 (-25 %) to 460 (+15 %); $I_n = 1$ A or 1-ph. AC 190 (-25 %) to 230 (+15 %); $I_n = 2$ A (-35 % for 1 min)
Rated supply voltage field ¹⁾	V	2-ph. AC 400 (+15 % / -20%) 2-ph. AC 460 (+10 %)
Rated frequency	Hz	The converters automatically adjust to the connected line frequency within a frequency range of 45 to 65 Hz ²⁾
Rated DC voltage field ¹⁾	V	Max. 325 / 373
Rated DC current field	A	40
Operational ambient temperature	°C	0 to +60
Storage and transport temperature	°C	-25 to +70
Control stability		$\Delta_n = 0.006$ % of the rated motor speed, valid for pulse encoder operation <u>and</u> digital setpoint $\Delta_n = 0.1$ % of the rated motor speed, valid for analog tacho and analog setpoint ³⁾
Environmental class	EN 60721-3-3	3K3
Degree of protection	EN 60529	IP 00
See dimension drawing on Page		18/14
Weight approx.	kg	15

Standards

DIN VDE 0106 Part 100	Protection against electric shock; location of actuators near live parts.
DIN VDE 0110 Part 1	Insulation coordination for electrical equipment in low-voltage installations. Pollution Severity 2 for boards and power section. Only non-conductive pollution is permissible. Temporary conductivity must however be accepted due to condensation. *Dewing is not permitted because the components are only approved for Humidity Class F*
EN 60146 T1-1 / DIN VDE 0558 T11	Semiconductor converters General requirements and line-commutated converters
DIN EN 50178 / DIN VDE 0160	Regulations for the equipment of electrical power installations with electronic equipment.
EN 61800-3	Variable-speed drives, Part 3, EMC product standard including special test procedures
DIN IEC 60 068-2-6 acc. to degree of severity 12 (SN29010 Part 1)	Mechanical stress

6

1) The field supply voltage can be less than the rated supply voltage field (set with Parameter P078.002; input voltages of up to 85 V are permissible). The output voltage is reduced accordingly. The specified output DC voltage can be guaranteed up to under-voltages 5 % below the supply voltage (rated supply voltage field).

2) Adaptation to the line frequency within a frequency range of 23 Hz to 110 Hz via [separate parameterization is available on request](#).

3) Conditions:

The control stability (PI control) is referred to the rated motor speed and applies when the SIMOREG converter is warm. The following conditions are applicable:

- Temperature changes of ± 10 °C
- Line voltage changes corresponding to +10% / 5% of the rated input voltage
- Temperature coefficient of temperature-compensated tacho-generators 0.15 % per 10 °C (applies only to analog tacho-generator)
- Constant setpoint (14-bit resolution)

SIMOREG 6RA70 DC MASTER SIMOREG CM

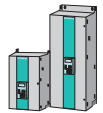

Block diagram

SIMOREG CM

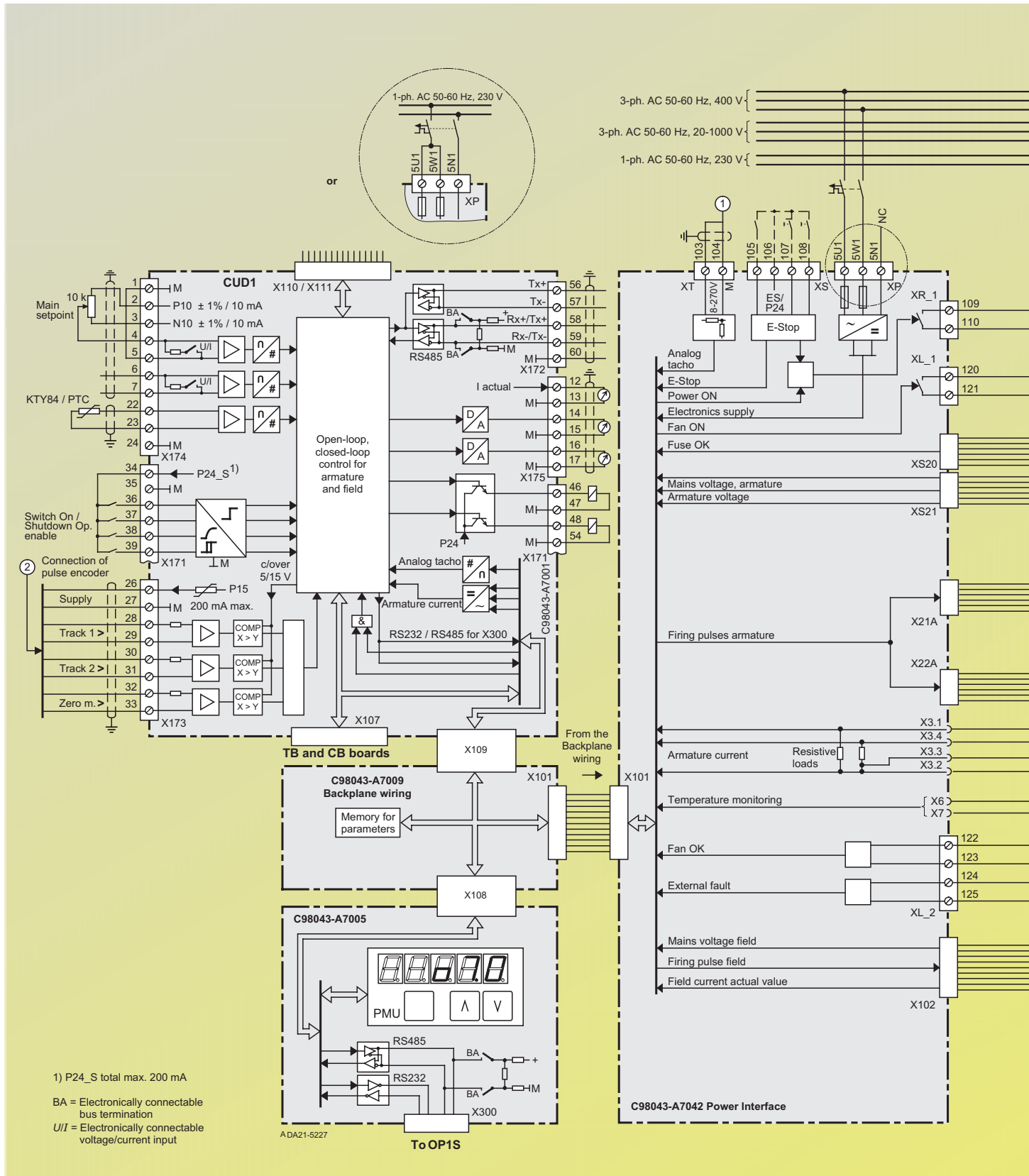

BA = Electronically connectable bus termination

UII = Electronically connectable voltage/current input

ADA21-5227

To OPIS

Fig. 6/2

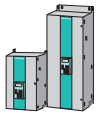

SIMOREG 6RA70 DC MASTER SIMOREG CM

Block diagram

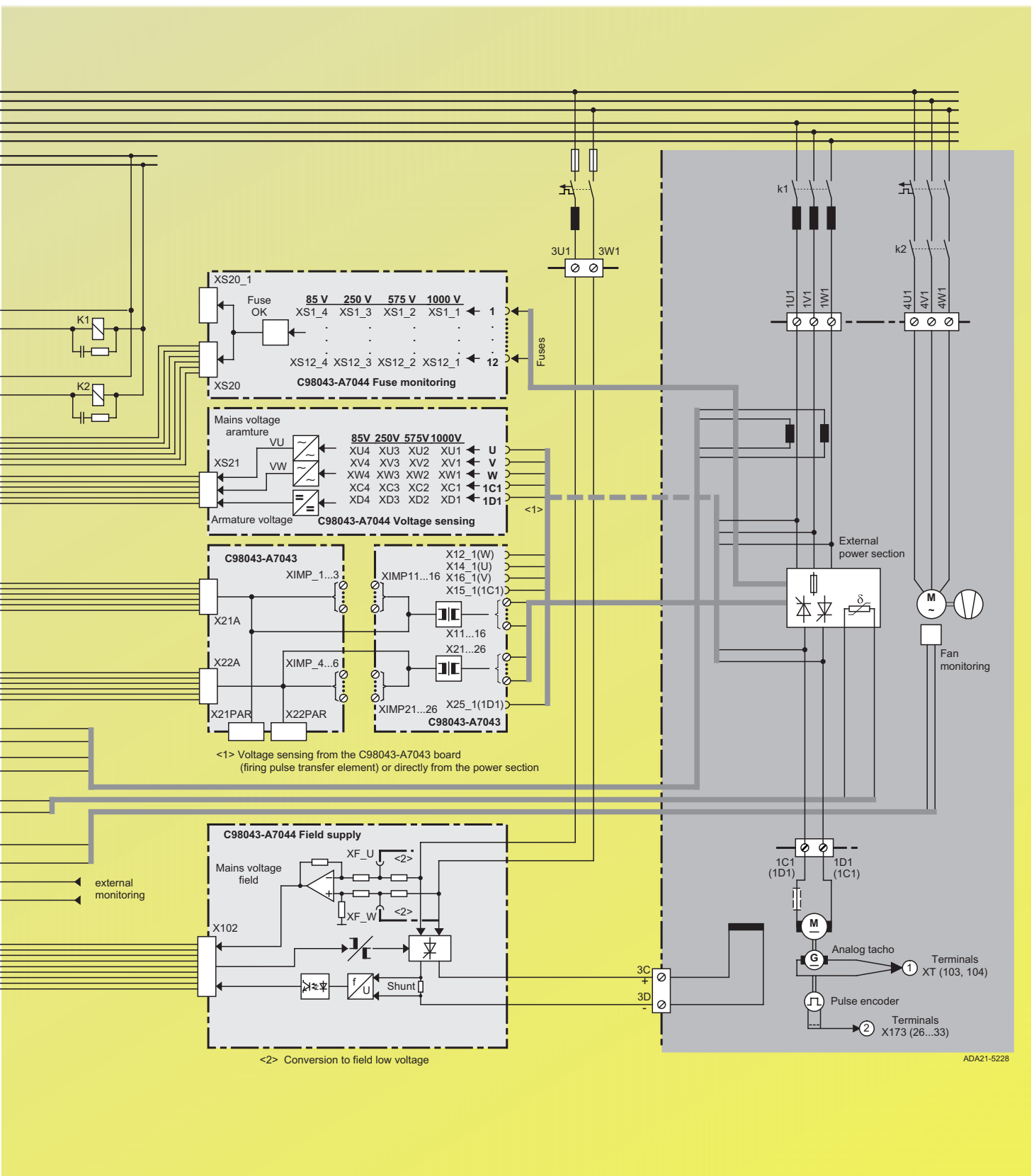

SIMOREG 6RA70 DC MASTER

SIMOREG CM

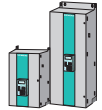

Options

The SIMOREG CM can be subdivided into several modules. These modules can be mounted separately.

Sets of preassembled cables are available as options for interconnecting the separate modules of the CM unit.

This allows fast, flexible adaptation to system requirements.

Description	Connection	Cable length	Order No.:
Preassembled ribbon cable set 2 off 26-core ribbon cable, shielded 2 off 10-core ribbon cable, shielded 1 off 20-core ribbon cable, shielded	From X21A, X22A on FBG -A7042- to X21A, X22A on FBG -A7043-	3 m	6RY1707-0CM01
	From XS20, XS21 on FBG -A7042- to XS20, XS21 on FBG -A7044- From X102 on FBG -A7042- to X102 on FBG -A7044-	10 m	6RY1707-0CM02
Preassembled cable set for current transformer 2 off 2-core twisted-pair cable	From X3 on FBG -A7042- to the current transformers	2 m	6RY1707-0CM03
		10 m	6RY1707-0CM04
Preassembled cable set for heat sink temperature sensing 1 off 2-core shielded cable	From X6 and X7 on FBG -A7042- to temperature sensor on KK	10 m	6RY1707-0CM05
Preassembled cable set for firing pulse cables Bridging set for 12 off 2-core twisted-pair cable	From XIMP11 through XIMP16 and XIMP21 through XIMP26 to the thyristors	3 m	6RY1707-0CM06
Preassembled cable set for the fuse monitoring system 6 off 2-core twisted-pair cable	From XS1_ through XS12_ (according to the voltage: 85 V, 250 V, 575 V or 1000 V) to the fuses	10 m	6RY1707-0CM07
Preassembled cable set for voltage measurement 1 off 3-core twisted-pair cable U-V-W 1 off 2-core twisted-pair cable C-D	From XU., XV., XW. (according to the voltage: 85 V, 250 V, 575 V or 1000 V) to the supply voltage terminals	3 m	6RY1707-0CM08
	From XC., XD. (according to the voltage: 85 V, 250 V, 575 V or 1000 V) to the armature voltage terminals		
Preassembled cable set for activation of the firing pulse transfer devices 12 off 2-core twisted-pair cable	From XIMP1, XIMP4 or XIMP2, XIMP5 or XIMP3, XIMP6 on FBG through A7043- (side panels) on the firing pulse transfer modules (single boards) with Terminals X11 through X16 and X21 through X26	1 m	6RY1707-0CM09
	2 off 12-core shielded cable	From XIMP1, XIMP4 and/or XIMP2, XIMP5 and/or XIMP3, XIMP6 on FBG -A7043- to external firing pulse transfer devices	10 m
Preassembled cable set for cradle in-line mounting 2 off 26-core ribbon cable 2 off 10-core ribbon cable 1 off 20-core ribbon cable	From X21A, X22A on FBG -A7042- to X21A, X22A on FBG -A7043- From XS20, XS21 on FBG -A7042- to XS20, XS21 on FBG -A7044- From X102 on FBG -A7042- to X102 on FBG -A7044-	–	6RY1707-0CM11

SIMOREG 6RA70 DC MASTER

Selection and Ordering Data



7/2
7/3

Chassis converters

Single-quadrant operation
Four-quadrant operation

7/3

SIMOREG CM Control Module

7/4
7/4
7/4

Electronics options

Ordering information
Options for the basic unit
Options for which an LBA or
LBA + ADB are necessary
Interface boards SCI1 and SCI2
Options for the SIMOREG CM unit

7/5
7/5

Miscellaneous options

7/6
7/6
7/6

Operating and monitoring
SIMOREG 6RL70 rectifier
Documentation

SIMOREG 6RA70 DC MASTER

Selection and Ordering Data

Chassis converters for
single-quadrant operation

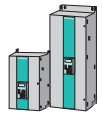

Rated data			Field circuit			Converter	Fuses		Excitation circuit			
Armature circuit							Armature circuit					
Rated supply voltage ¹⁾	Rated DC voltage	Rated DC current	Rated output	Rated supply voltage ¹⁾	Rated DC current		Phase ⁴⁾	DC current ⁴⁾				
V	V	A	kW	V	A	Order No.:	Order No.:	Order No.:	Each unit Order No.			
3-ph. AC 400	485	30	14.5	2-ph. AC 400	5	6RA7018-6DS22-0	3NE1815-0	–	5SD420			
		60	29		10	6RA7025-6DS22-0	3NE1817-0	–	5SD420			
		90	44		10	6RA7028-6DS22-0	3NE1820-0	–	5SD420			
		125	61		10	6RA7031-6DS22-0	3NE1021-0	–	5SD420			
	210	400	210	102	2-ph. AC 400	15	6RA7075-6DS22-0	3NE3227	–	5SD440		
			280	136		15	6RA7078-6DS22-0	3NE3231	–	5SD440		
			400	194	2-ph. AC 400	25	6RA7081-6DS22-0	3NE3233	–	5SD440		
			600	291		25	6RA7085-6DS22-0	3NE3336	–	5SD440		
			1200	1600	850	412	2-ph. AC 400	30	6RA7087-6DS22-0	3NE3338-8	–	5SD480
					1200	582		30	6RA7091-6DS22-0	²⁾	–	5SD480
					1600	776		40	6RA7093-6DS22-0	²⁾	–	3NE1802-0 ⁴⁾
					2000	970		40	6RA7095-6DS22-0	²⁾	–	3NE1802-0 ⁴⁾
			3-ph. AC 460	550	30	16.5	2-ph. AC 460	5	6RA7018-6FS22-0	3NE1815-0	–	5SD420
					60	33		10	6RA7025-6FS22-0	3NE1817-0	–	5SD420
90	49.5	10			6RA7028-6FS22-0	3NE1820-0		–	5SD420			
125	210	125		68.7	2-ph. AC 460	10	6RA7031-6FS22-0	3NE1021-0	–	5SD420		
		210		115		15	6RA7075-6FS22-0	3NE3227	–	5SD440		
		280		154		15	6RA7078-6FS22-0	3NE3231	–	5SD440		
450	600	450		247	2-ph. AC 460	25	6RA7082-6FS22-0	3NE3233	–	5SD440		
		600		330		25	6RA7085-6FS22-0	3NE3336	–	5SD440		
		850		467		30	6RA7087-6FS22-0	3NE3338-8	–	5SD480		
		1200		660		30	6RA7091-6FS22-0	²⁾	–	5SD480		
		3-ph. AC 575		690		60	41	2-ph. AC 460	10	6RA7025-6GS22-0	3NE1817-0	–
125	86				10	6RA7031-6GS22-0	3NE1021-0		–	5SD420		
210	145				15	6RA7075-6GS22-0	3NE3227		–	5SD440		
400	600			400	276	2-ph. AC 460	25	6RA7081-6GS22-0	3NE3233	–	5SD440	
			600	414	25		6RA7085-6GS22-0	3NE3336	–	5SD440		
			800	552	30		6RA7087-6GS22-0	3NE3338-8	–	5SD480		
1000	1600		1000	690	2-ph. AC 460	30	6RA7090-6GS22-0	²⁾	–	5SD480		
			1600	1104		40	6RA7093-4GS22-0	²⁾	–	3NE1802-0 ⁴⁾		
			2000	1380		40	6RA7095-4GS22-0	²⁾	–	3NE1802-0 ⁴⁾		
			3-ph. AC 690	830		720	598	2-ph. AC 460	30	6RA7086-6KS22-0	3NE3337-8	–
950	789	30			6RA7088-6KS22-0	²⁾	–		5SD480			
1500	2000	1500		1245	2-ph. AC 460	40	6RA7093-4KS22-0	²⁾	–	3NE1802-0 ⁴⁾		
		2000		1660		40	6RA7095-4KS22-0	²⁾	–	3NE1802-0 ⁴⁾		
3-ph. AC 830	1000	900		900	2-ph. AC 460	30	6RA7088-6LS22-0	²⁾	–	5SD480		
		1500		1500		40	6RA7093-4LS22-0	²⁾	–	3NE1802-0 ⁴⁾		
		1900		1900		40	6RA7095-4LS22-0	²⁾	–	3NE1802-0 ⁴⁾		

7

1) 50/60 Hz

2) Integrated branch fuses,
no external semiconductor protection devices are necessary

3) Parallel connection

4) UL recognized

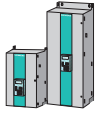

SIMOREG 6RA70 DC MASTER

Selection and Ordering Data

Chassis converters for four-quadrant operation

Rated data Armature circuit			Field circuit			Converter	Fuses Armature circuit		Excitation circuit	
Rated supply voltage ¹⁾	Rated DC voltage	Rated DC current	Rated output	Rated supply voltage ¹⁾	Rated DC current		Phase ⁴⁾	DC current ⁴⁾		
V	V	A	kW	V	A	Order No.:	Order No.:	Order No.:	Each unit Order No.	
3-ph. AC 400	420	15	6.3	2-ph. AC 400	3	6RA7013-6DV62-0	3NE1814-0	3NE1814-0	5SD420	
		30	12.6		5	6RA7018-6DV62-0	3NE1815-0	3NE4102	5SD420	
		60	25		10	6RA7025-6DV62-0	3NE1817-0	3NE4120	5SD420	
		90	38		10	6RA7028-6DV62-0	3NE1820-0	3NE4122	5SD420	
		125	52.5		2-ph. AC 400	10	6RA7031-6DV62-0	3NE1021-0	3NE4124	5SD420
	210	88	15	6RA7075-6DV62-0		3NE3227	3NE3227	5SD440		
	280	118	15	6RA7078-6DV62-0		3NE3231	3NE3231	5SD440		
	400	168	25	6RA7081-6DV62-0		3NE3233	3NE3233	5SD440		
	600	252	2-ph. AC 400	25		6RA7085-6DV62-0	3NE3336	3NE3336	5SD440	
	850	357		30	6RA7087-6DV62-0	3NE3338-8	3NE3334-0B ³⁾	5SD480		
	1200	504		30	6RA7091-6DV62-0	²⁾	²⁾	5SD480		
	1600	672		40	6RA7093-4DV62-0	²⁾	²⁾	3NE1802-0 ⁴⁾		
	2000	840		40	6RA7095-4DV62-0	²⁾	²⁾	3NE1802-0 ⁴⁾		
	3-ph. AC 460	480	30	14.4	2-ph. AC 460	5	6RA7018-6FV62-0	3NE1815-0	3NE4102	5SD420
			60	28.8		10	6RA7025-6FV62-0	3NE1817-0	3NE4120	5SD420
90			43	10		6RA7028-6FV62-0	3NE1820-0	3NE4122	5SD420	
2-ph. AC 460		125	60	2-ph. AC 460	10	6RA7031-6FV62-0	3NE1021-0	3NE4124	5SD420	
		210	100		15	6RA7075-6FV62-0	3NE3227	3NE3227	5SD440	
		280	134		15	6RA7078-6FV62-0	3NE3231	3NE3231	5SD440	
		450	216		2-ph. AC 460	25	6RA7082-6FV62-0	3NE3233	3NE3334-0B ³⁾	5SD440
		600	288			25	6RA7085-6FV62-0	3NE3336	3NE3336	5SD440
850		408	30	6RA7087-6FV62-0		3NE3338-8	3NE3334-0B ³⁾	5SD480		
1200		576	30	6RA7091-6FV62-0	²⁾	²⁾	5SD480			
3-ph. AC 575		600	60	36	2-ph. AC 460	10	6RA7025-6GV62-0	3NE1817-0	3NE4120	5SD420
			125	75		10	6RA7031-6GV62-0	3NE1021-0	3NE4124	5SD420
			210	126		15	6RA7075-6GV62-0	3NE3227	3NE3227	5SD440
		2-ph. AC 460	400	240	2-ph. AC 460	25	6RA7081-6GV62-0	3NE3233	3NE3233	5SD440
			600	360		25	6RA7085-6GV62-0	3NE3336	3NE3336	5SD440
	850		510	30		6RA7087-6GV62-0	3NE3338-8	3NE3334-0B ³⁾	5SD480	
	1100		660	2-ph. AC 460		30	6RA7090-6GV62-0	²⁾	²⁾	5SD480
	1600		960			40	6RA7093-4GV62-0	²⁾	²⁾	3NE1802-0 ⁴⁾
	2000	1200	40		6RA7095-4GV62-0	²⁾	²⁾	3NE1802-0 ⁴⁾		
	3-ph. AC 690	725	760	551	2-ph. AC 460	30	6RA7086-6KV62-0	3NE3337-8	3NE3334-0B ³⁾	5SD480
			1000	725		30	6RA7090-6KV62-0	²⁾	²⁾	5SD480
			1500	1088		40	6RA7093-4KV62-0	²⁾	²⁾	3NE1802-0 ⁴⁾
			2000	1450		40	6RA7095-4KV62-0	²⁾	²⁾	3NE1802-0 ⁴⁾
			3-ph. AC 830	875		950	831	2-ph. AC 460	30	6RA7088-6LV62-0
	1500	1313			40	6RA7093-4LV62-0	²⁾		²⁾	3NE1802-0 ⁴⁾
1900	1663	40			6RA7095-4LV62-0	²⁾	²⁾		3NE1802-0 ⁴⁾	

SIMOREG CM Control Module 6RA70

Rated data Armature circuit				Field circuit		SIMOREG CM	Fuses Excitation circuit
Rated supply voltage ¹⁾	Rated DC voltage	Rated DC current	Rated output	Rated supply voltage ¹⁾	Rated DC current		Each unit Order No.:
V	V	A	kW	V	A	Order No.:	
3AC 85/250/575/1000	–	–	–	2-ph. AC 460	40	6RA7000-0MV62-0	3NE1802-0 ⁴⁾

- 1) 50/60 Hz
- 2) Integrated branch fuses, no external semiconductor protection devices are necessary
- 3) Parallel connection
- 4) UL recognized

SIMOREG 6RA70 DC MASTER

Selection and Ordering Data

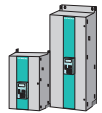

Electronics options

Ordering information

When a SIMOREG converter is ordered with an additional option, the suffix "-Z" plus the appropriate short code must be added to the converter order number.

6RA70 - - - - - **0-Z**
 □□□ + □□□ + ...

The options ordered with the short code are supplied installed by the factory.

Order No. of the SIMOREG unit short codes (several order codes can be added in sequence)

Options for the basic unit

Board	Description	Code	Order No.:
	Technology software in the basic unit ("freely-definable function blocks")	S00	6RX1700-0AS00
CUD2	Terminal expansion board for basic unit	K00	6RX1700-0AK00
	Parallel connection cable		6RY1707-0AA08

Options for which an LBA or LBA + ADB are necessary

Board	Description	Code	Order No.:
LBA	Local Bus Adapter for the electronics box Prerequisite for installing optional supplementary boards	-	6SE7090-0XX84-4HA0
ADB	Adapter board ¹⁾ Prerequisite for installing SBP, EB1, EB2, SLB, CBP2, CBC and CBD	-	6SE7090-0XX84-0KA0
SBP	Pulse encoder evaluation board ^{1) 2) 3)} (small-format board; ADB is necessary)	-	6SX7010-0FA00
EB1	Terminal expansion board ^{1) 3)} (small-format board; ADB is necessary)	-	6SX7010-0KB00
EB2	Terminal expansion board ^{1) 3)} (small-format board; ADB is necessary)	-	6SX7010-0KC00
SLB	SIMOLINK board ^{1) 3)} (small-format board; ADB is necessary)	-	6SX7010-0FJ00
CBP2	Communication board with interface for SINEC L2 DP, (PROFIBUS-DP) ^{1) 3)} (small-format board; ADB is necessary)	-	6SX7010-0FF05
CBC	Communication board with interface for CAN protocol ^{1) 3)} (small-format board; ADB is necessary)	-	6SX7010-0FG00
CBD	Communication board with interface for DeviceNet protocol ^{1) 3)} (small-format board; ADB is necessary)	-	6SX7010-0FK00
SCB1	Interface board with fiber-optic cable connection Supplied incl. 10 m fiber-optic cable	-	6SE7090-0XX84-0BC0
T100	Technology board incl. hardware manual without software module ³⁾	-	6SE7090-0XX87-0BB0
	Hardware manual for T100	-	6SE7080-0CX87-0BB0
MS100	Software module "Universal drive" for T100 (EPROM) without manual	-	6SE7098-0XX84-0BB0
	Manual for software module MS100 "Universal drive"		
	• German	-	6SE7080-0CX84-0BB1
	• English	-	6SE7087-6CX84-0BB1
	• French	-	6SE7087-7CX84-0BB1
	• Spanish	-	6SE7087-8CX84-0BB1
	• Italian	-	6SE7087-2CX84-0BB1
T300	Technology board with 2 connecting cables SC58 and SC60, terminal strip SE300 and hardware manual ³⁾	-	6SE7090-0XX87-4A00
T400	Technology board (incl. Brief Description) ³⁾	-	6DD1606-0AD0
	User's Guide for T400 hardware and configuration	-	6DD1903-0EA0

7

1) These supplementary boards are supplied as a retrofit kit (with connector and Brief Description). The boards can be ordered as **spare parts** with the following order numbers:

Board	Spare part (no accessories) Order No.:
SBP	6SE7090-0XX84-0FA0
EB1	6SE7090-0XX84-0KB0
EB2	6SE7090-0XX84-0KC0
SLB	6SE7090-0XX84-0FJ0
CBP2	6SE7090-0XX84-0FF5
CBC	6SE7090-0XX84-0FG0
CBD	6SE7090-0XX84-0FK0

The retrofit kit is required for installation in the SIMOREG unit to ensure that the connectors required for system installation and the Brief Description are obtained.

For installation of the boards in the SIMOREG unit, the Local Bus Adapter LBA and the Adapter Board ADB are also required. These must be ordered separately.

2) The SIMOREG unit is already equipped with a pulse encoder evaluation board in the basic unit, so the SBP is only necessary when a second pulse encoder is to be evaluated.

3) For installation of the board in the SIMOREG unit, the Local Bus Adapter LBA is also required. This must be ordered separately.

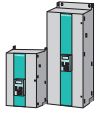

SIMOREG 6RA70 DC MASTER

Selection and Ordering Data

Electronics options

Interface boards SCI1 and SCI2

Interface boards SCI1 and SCI2 and interface board SCB1 can be used to assemble a serial I/O system with a fiber-optic conductor that can expand the binary and analog inputs and outputs considerably.

Board	Description	Order No.:
SCI1	Interface board binary and analog inputs/outputs supplied with 10 m fiber-optic cable	6SE7090-0XX84-3EA0
SCI2	Interface board binary inputs/outputs supplied with 10 m fiber-optic cable	6SE7090-0XX84-3EF0

Options for the SIMOREG CM unit

Description	Length	Order No.:
Preassembled ribbon cable set 2 off 26-core ribbon cable, shielded 2 off 10-core ribbon cable, shielded 1 off 20-core ribbon cable, shielded	3 m 10 m	6RY1707-0CM01 6RY1707-0CM02
Preassembled cable set for current transformer 2 off 2-core twisted-pair cable	2 m 10 m	6RY1707-0CM03 6RY1707-0CM04
Preassembled cable set for heat-sink temperature sensing 1 off 2-core shielded cable	10 m	6RY1707-0CM05
Preassembled cable set for firing pulse leads Bridging kit for 12 off 2-core twisted-pair cable	3 m	6RY1707-0CM06
Preassembled cable set for fuse monitoring 6 off 2-core twisted-pair cable	10 m	6RY1707-0CM07
Preassembled cable set for voltage sensing 1 off 3-core twisted-pair cable U-V-W 1 off 2-core twisted-pair cable	3 m	6RY1707-0CM08
Preassembled cable set for activation of the firing pulse transfer elements 12 off 2-core twisted-pair cable	1 m	6RY1707-0CM09
2 off 12-core shielded cable	10 m	6RY1707-0CM10
Preassembled cable set for cradle mounting side by side 2 off 26-core ribbon cable 2 off 10-core ribbon cable 1 off 20-core ribbon cable		6RY1707-0CM11

SIMOREG 6RA70 DC MASTER

Selection and Ordering Data

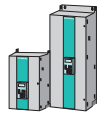

Miscellaneous options

Operating and monitoring

Description	Length	Order No.:
Connecting cable DriveMonitor PC – PMU (RS232)	3 m	6SX7005-0AB00
Interface converter SU1 RS232 - RS485, including mounting accessories, connection to power supply: 1 CA 115 V / 230 V	–	6SX7005-0AA00
OP1S operator panel	–	6SE7090-0XX84-2FK0
Adapter AOP1 for cabinet door mounting of OP1S Including 5 m connecting cable	–	6SX7010-0AA00
Connecting cable PMU – OP1S	3 m 5 m	6SX7010-0AB03 6SX7010-0AB05

SIMOREG 6RL70 rectifier module

Rated data armature circuit				Order No.:	Fuses armature circuit Phase ³⁾
Rated supply voltage ¹⁾	Rated DC voltage	Rated DC current	Rated power		
V	V	A	kW		Order No.:
3-ph. AC 690	930	1000	930	6RL7091-6KS00-0	²⁾
3-ph. AC 690	930	2000	1860	6RL7095-4KS00-0	²⁾

Documentation

Description	Code	Order No.:
SIMOREG DC MASTER operating instructions The converters are supplied with a Brief Description, Operating Instructions must be ordered. • German • Italian • English • French • Spanish	D00 D72 D76 D77 D78	6RX1700-0AD00 6RX1700-0AD72 6RX1700-0AD76 6RX1700-0AD77 6RX1700-0AD78
Operating Instructions and DriveMonitor in all the languages listed above on CD-ROM	D64	6RX1700-0AD64
SIMOREG CM operating instructions The units are supplied with German Operating Instructions as standard, other language versions must be ordered. • German • Italian • English • French • Spanish	– D72 D76 D77 D78	6RX1700-0BD00 6RX1700-0BD72 6RX1700-0BD76 6RX1700-0BD77 6RX1700-0BD78
Operating Instructions and DriveMonitor in all the languages listed above on CD-ROM	D64	6RX1700-0BD64
SIMOREG 6RL70 operating instructions The units are supplied with Operating Instructions in five languages. English, German, French, Italian and Spanish	–	6RX1700-0CD64

7

1) 50/60 Hz

2) Integrated branch fuses,
no external semiconductor protection devices are necessary

3) UL recognized



SIMOREG 6RA70 DC MASTER Dimension Drawings



Converters for single-quadrant operation

8/2	3-ph. AC 400 V and 460 V, 30 A
8/2	3-ph. AC 400 V and 575 V, 60 A to 280 A
8/3	3-ph. AC 400 V and 575 V, 400 A
8/3	3-ph. AC 400 V and 575 V, 600 A
8/4	3-ph. AC 400 V, 575 V and 690 V, 720 A to 850 A
8/4	3-ph. AC 400 V, 460 V, 575 V, 690 V and 830 V, 900 A to 1200 A
8/5	3-ph. AC 400 V, 575 V, 690 V and 830 V, 1500 A to 1200 A

Converters for four-quadrant operation

8/6	3-ph. AC 400 V and 460 V, 15 A to 30 A
8/6	3-ph. AC 400 V and 575 V, 60 A to 280 A
8/7	3-ph. AC 400 V and 575 V, 400 A to 600 A
8/7	3-ph. AC 400 V, 575 V and 690 V, 760 A to 850 A
8/8	3-ph. AC 400 V, 460 V, 575 V, 690 V and 830 V, 950 A to 1200 A
8/8	3-ph. AC 400 V, 575 V, 690 V and 830 V, 1500 A to 2000 A

Converters with additional power circuit terminals on their top panel

8/9	3-ph. AC 460 V, 60 A to 125 A, 1Q
8/9	3-ph. AC 460 V, 210 A to 280 A, 1Q
8/10	3-ph. AC 460 V, 450 A to 600 A, 1Q
8/10	3-ph. AC 460 V, 850 A, 1Q
8/11	3-ph. AC 460 V, 60 A to 125 A, 4Q
8/11	3-ph. AC 460 V, 210 A to 280 A, 4Q
8/12	3-ph. AC 460 V, 450 A to 600 A, 4Q
8/12	3-ph. AC 460 V, 850 A, 4Q

6RL70 rectifier module

8/13	3-ph. AC 690 V, 1000 A
8/13	3-ph. AC 690 V, 2000 A

SIMOREG CM

8/14	Device components assembled
8/14	Device components alongside each other

SIMOREG 6RA70 DC MASTER

Dimension Drawings

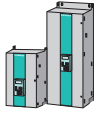

Converters for single-quadrant operation

3-ph. AC 400 V and 460 V, 30 A

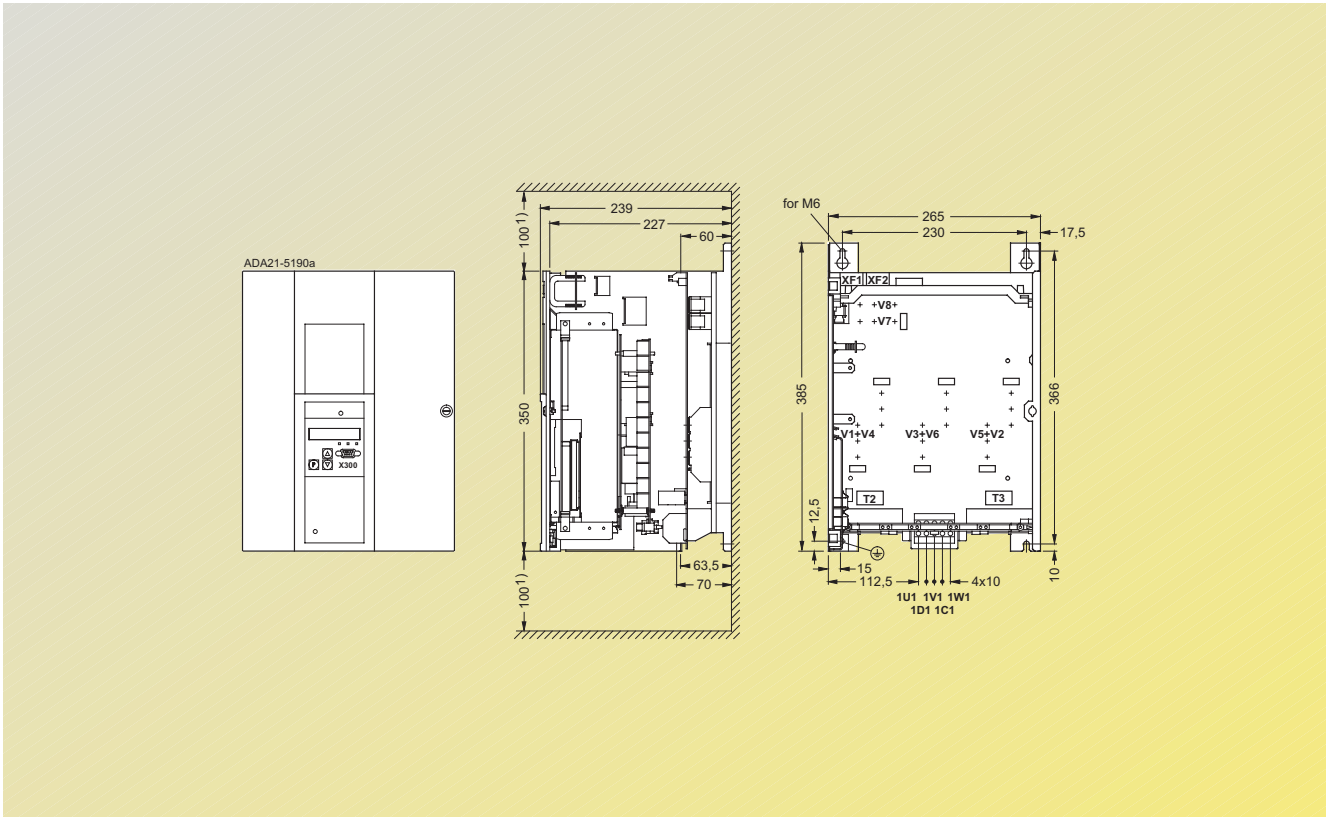

Fig. 8/1

3-ph. AC 400 V and 575 V, 60 A to 280 A

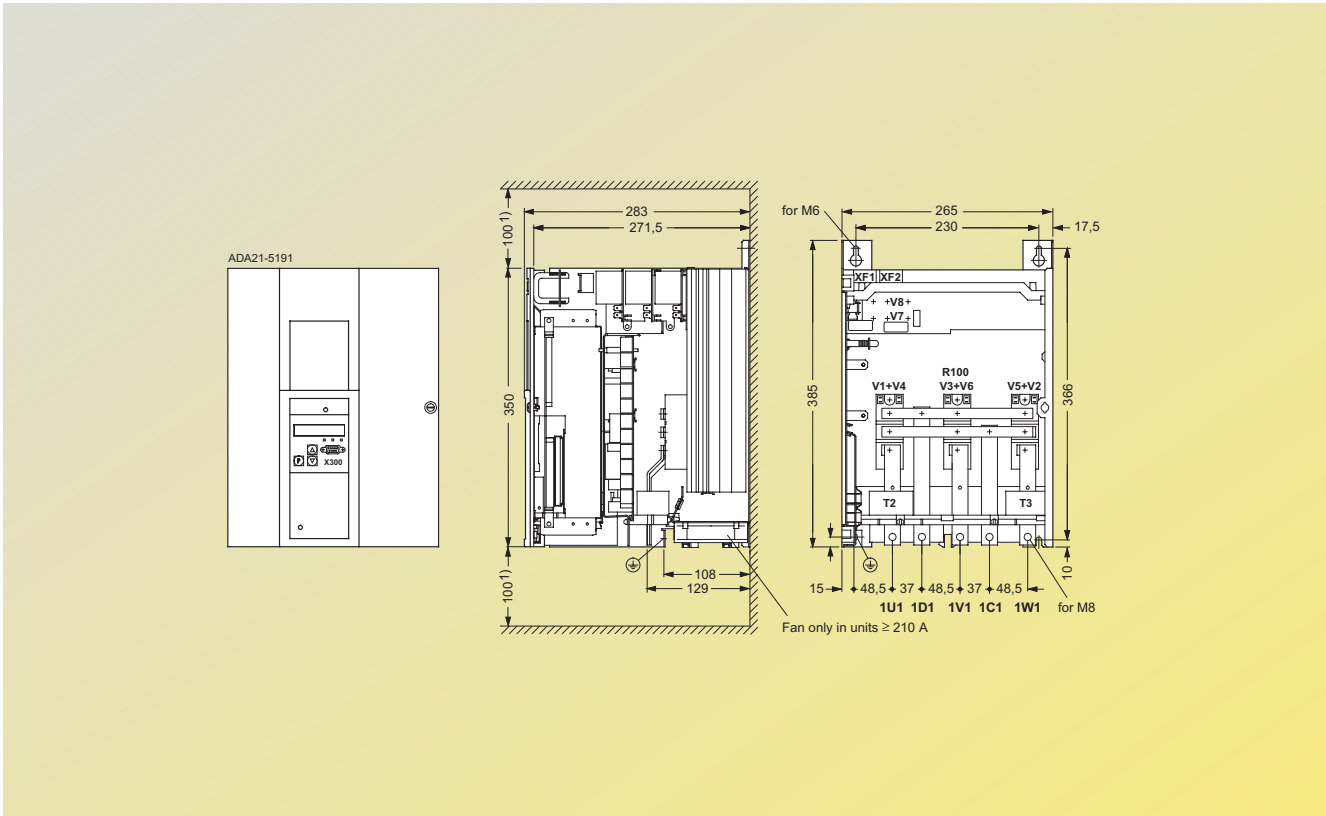
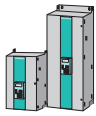

Fig. 8/2

1) Minimum free space for air circulation; it is necessary to ensure that the cooling air intake is sufficient.



SIMOREG 6RA70 DC MASTER Dimension Drawings

Converters for single-quadrant operation

3-ph. AC 400 V and 575 V, 400 A

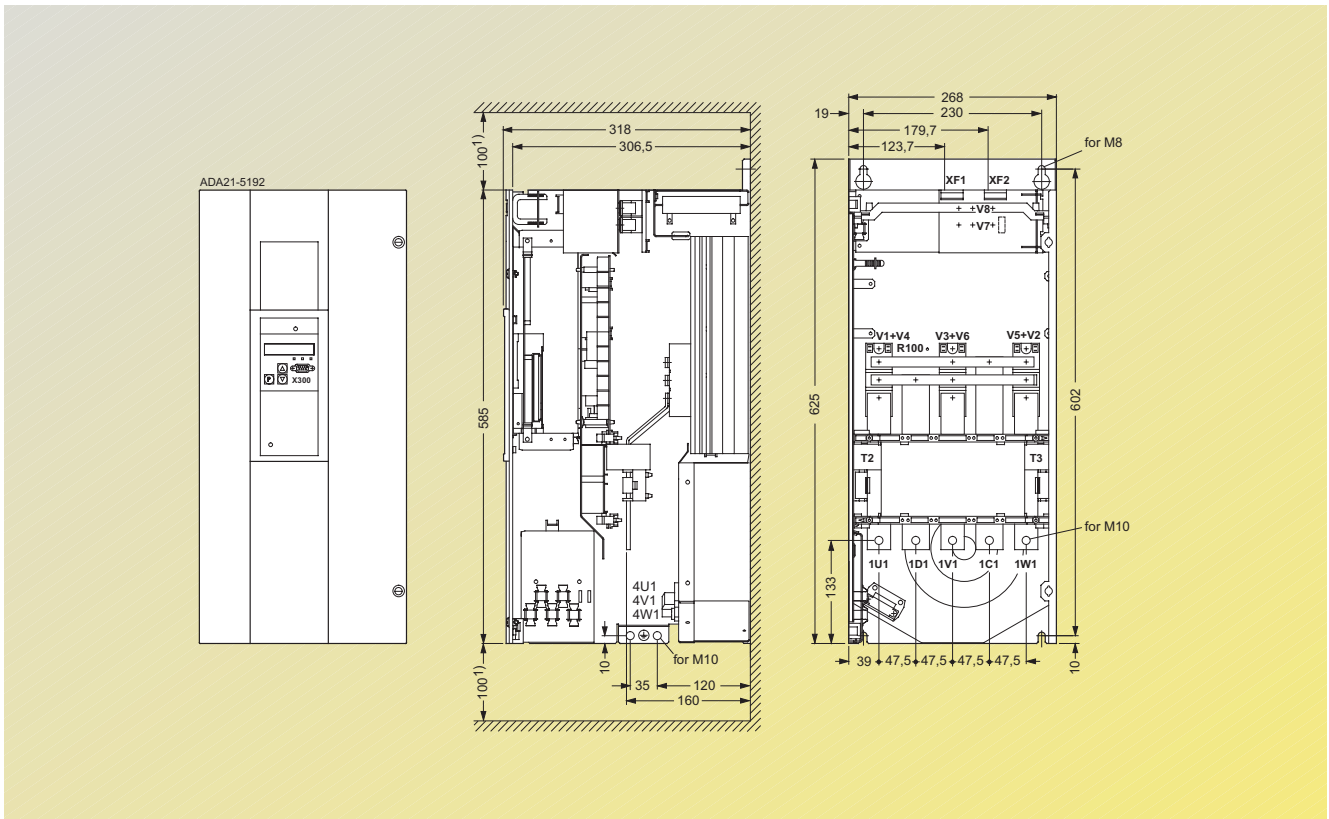

Fig. 8/3

3-ph. AC 400 V and 575 V, 600 A

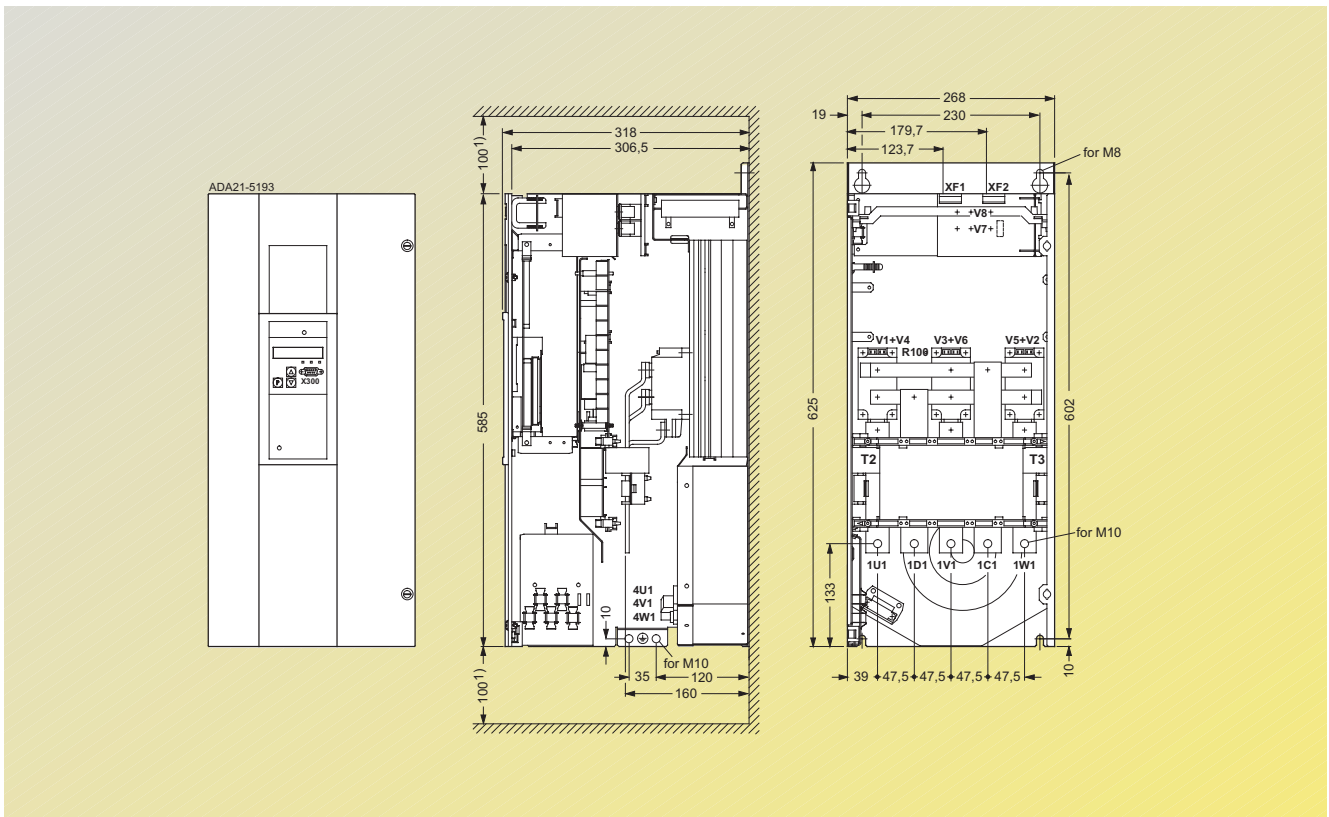
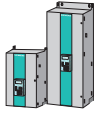

Fig. 8/4

1) Minimum free space for air circulation; it is necessary to ensure that the cooling air intake is sufficient.

SIMOREG 6RA70 DC MASTER

Dimension Drawings



Converters for single-quadrant operation

3-ph. AC 400 V, 575 V and 690 V, 720 A to 850 A

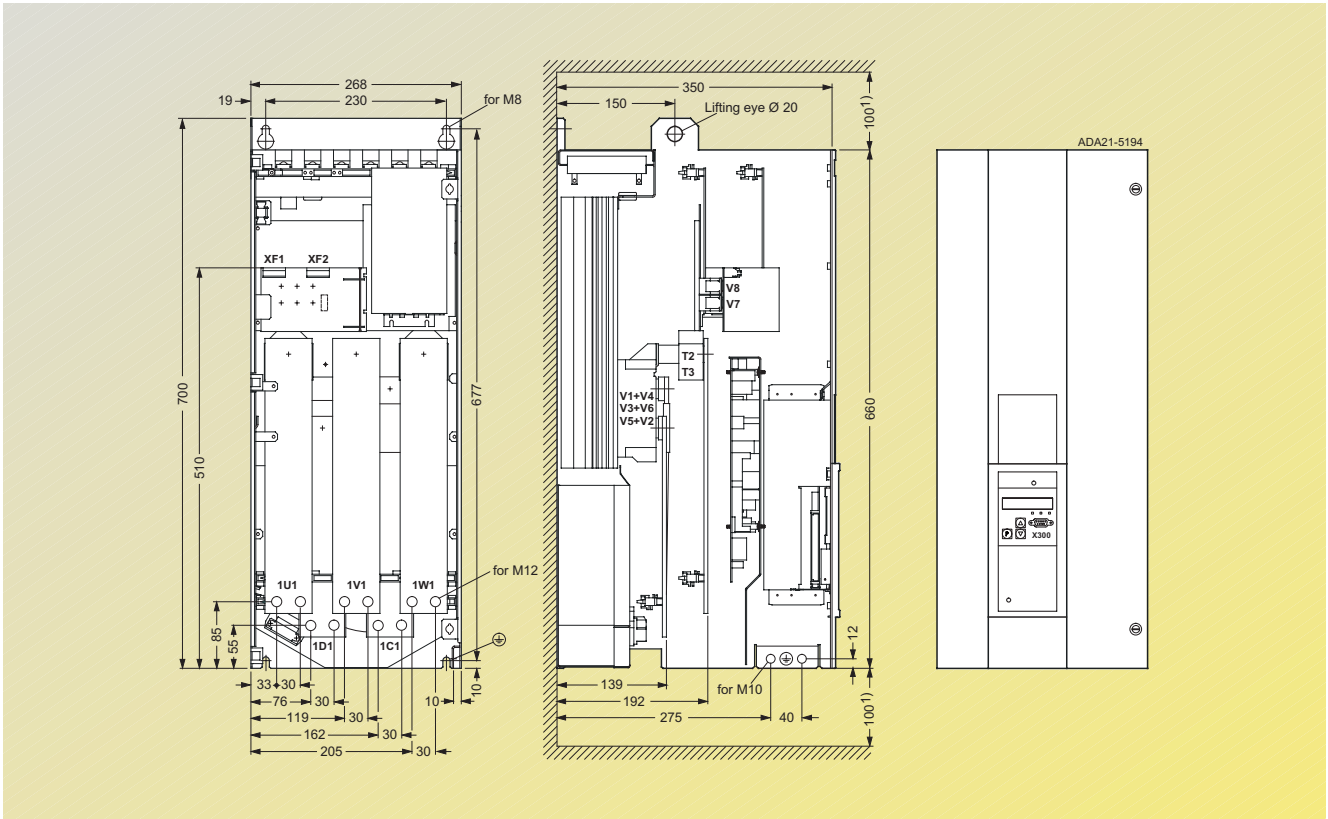

Fig. 8/5

3-ph. AC 400 V, 460 V, 575 V, 690 V and 830 V, 900 A to 1200 A

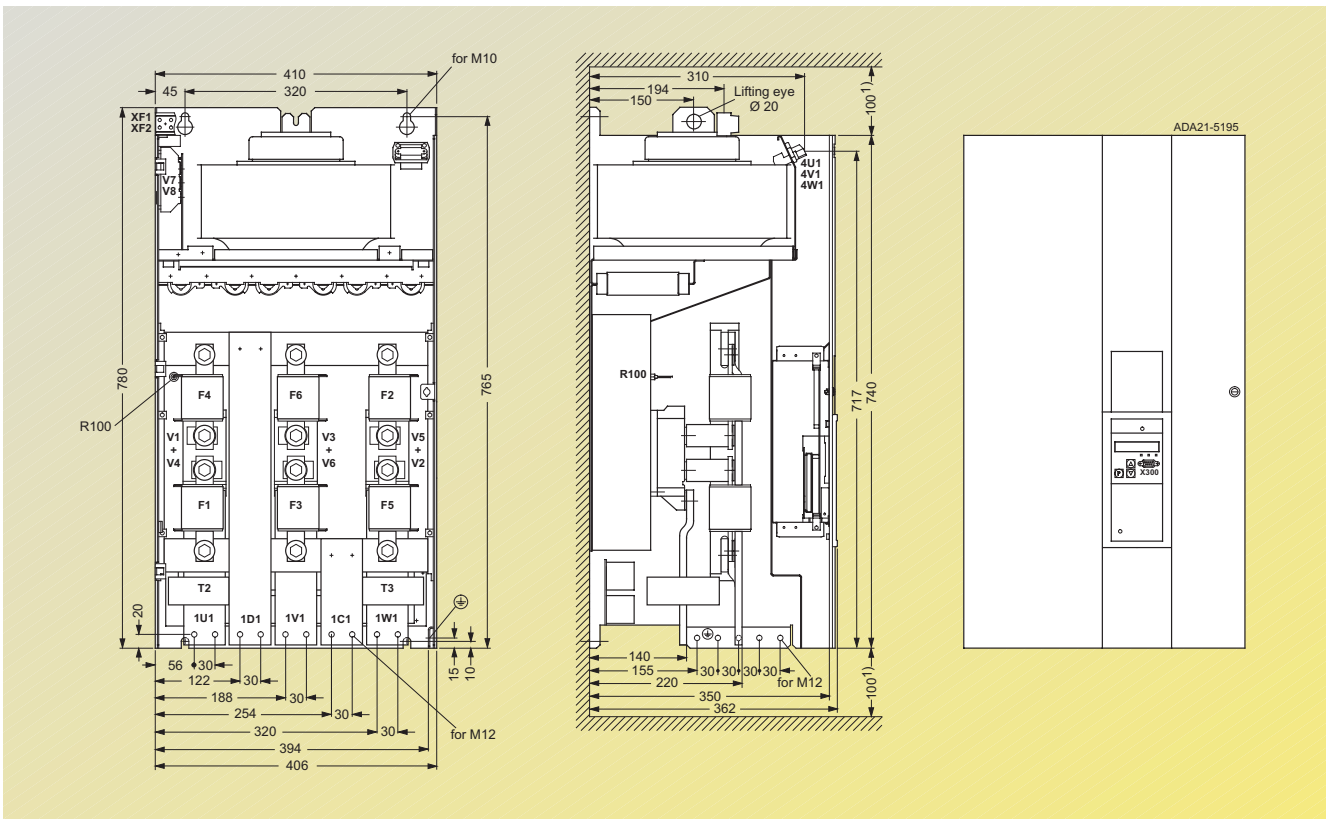
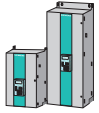

Fig. 8/6

1) Minimum free space for air circulation; it is necessary to ensure that the cooling air intake is sufficient.

SIMOREG 6RA70 DC MASTER

Dimension Drawings



Converters for four-quadrant operation

3-ph. AC 400 V and 460 V, 15 A to 30 A

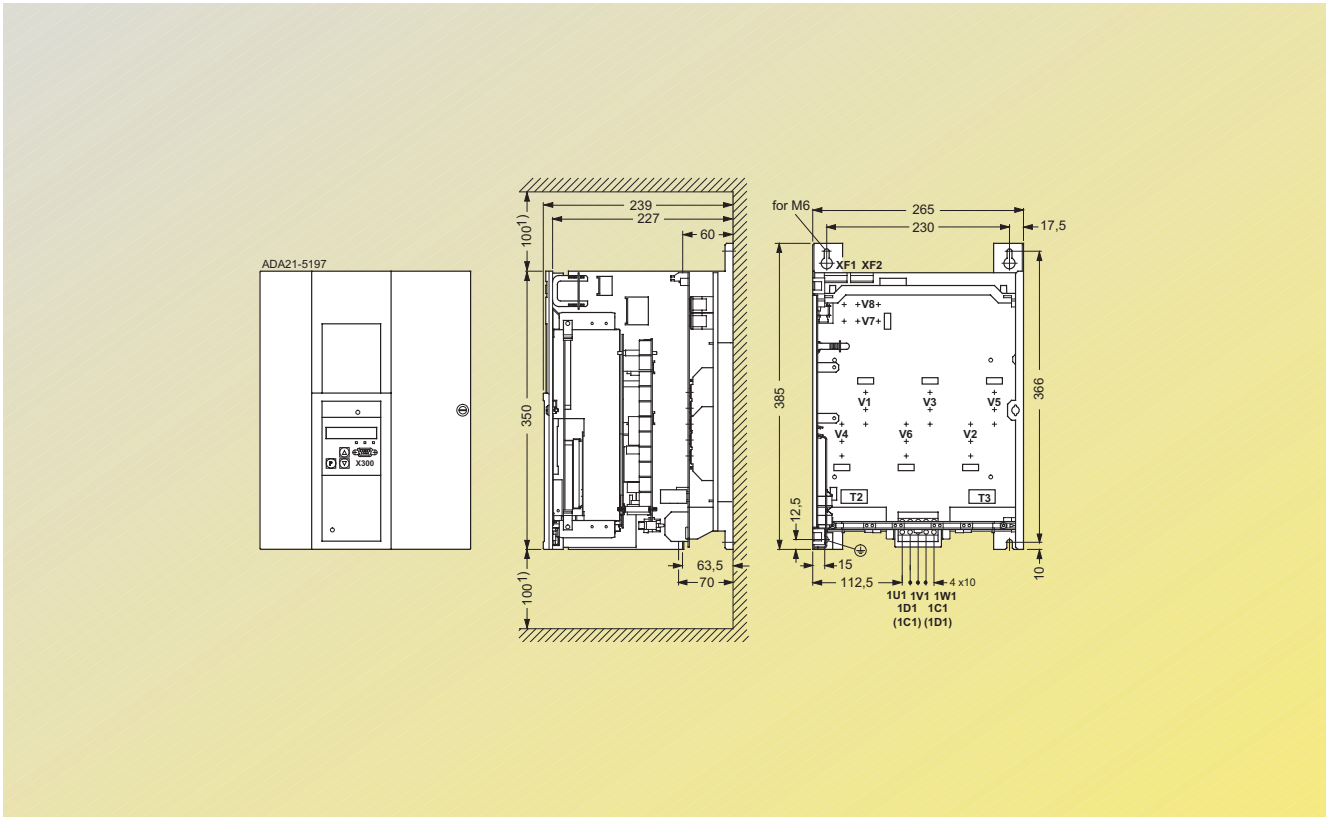

Fig. 8/8

3-ph. AC 400 V and 575 V, 60 A to 280 A

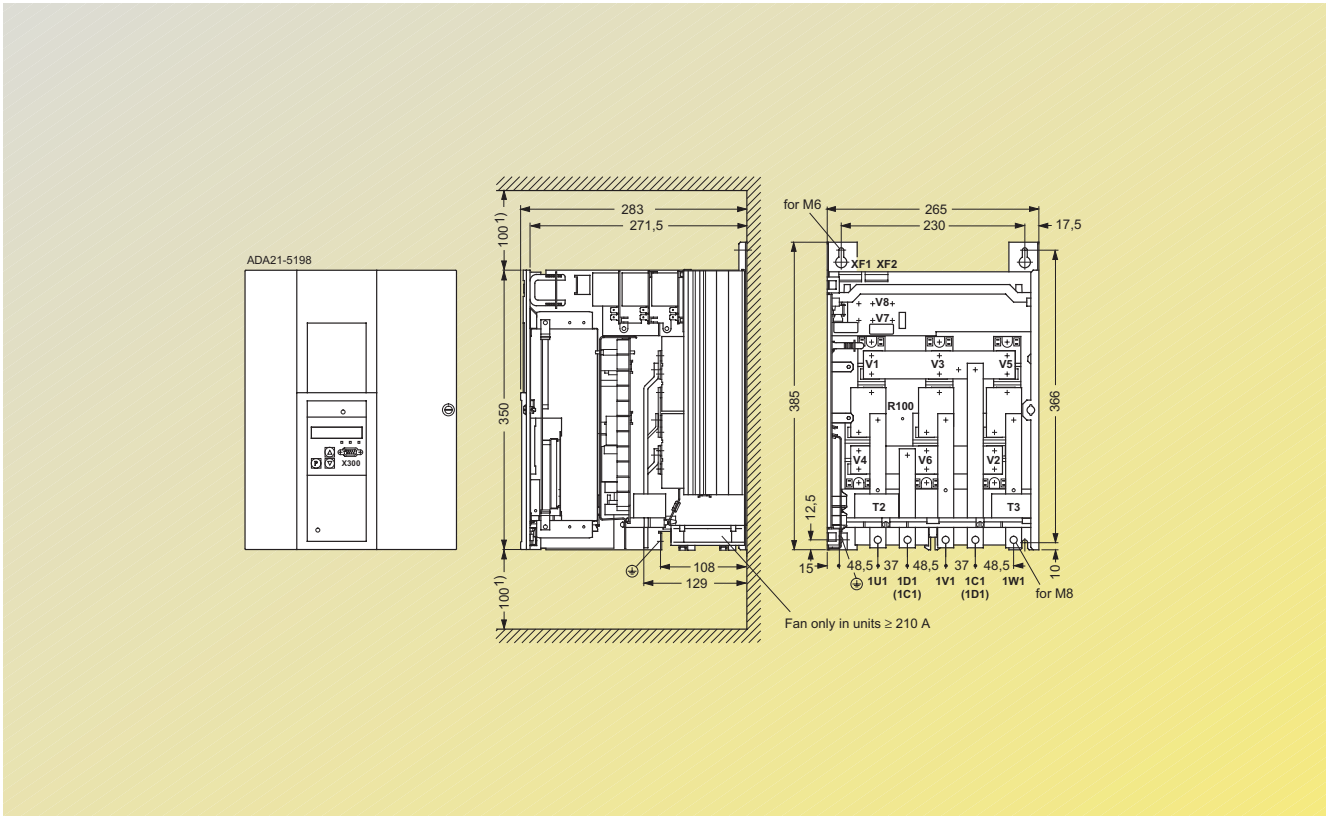
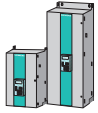

Fig. 8/9

1) Minimum free space for air circulation; it is necessary to ensure that the cooling air intake is sufficient.



SIMOREG 6RA70 DC MASTER Dimension Drawings

Converters for four-quadrant operation

3-ph. AC 400 V and 575 V, 400 A to 600 A

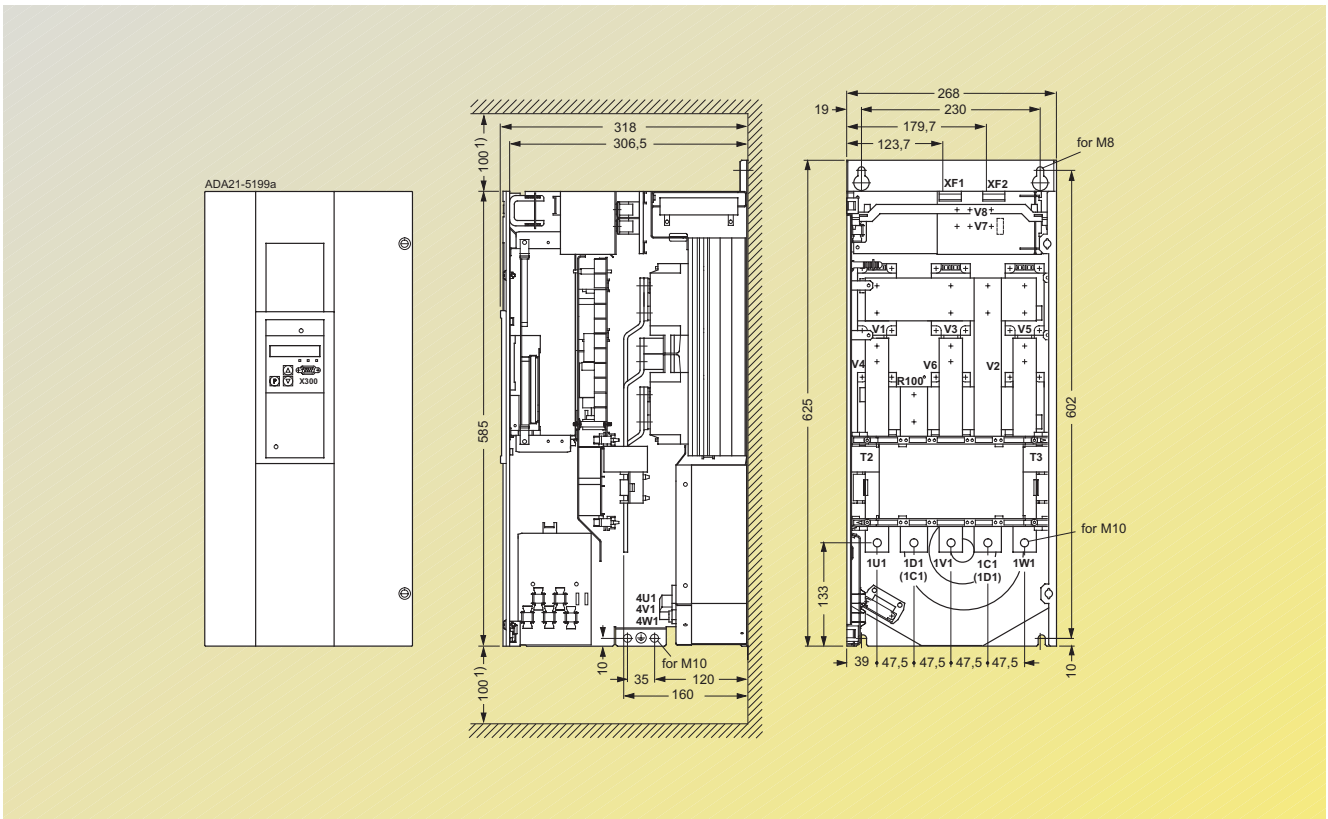

Fig. 8/10

3-ph. AC 400 V, 575 V and 690 V, 760 A to 850 A

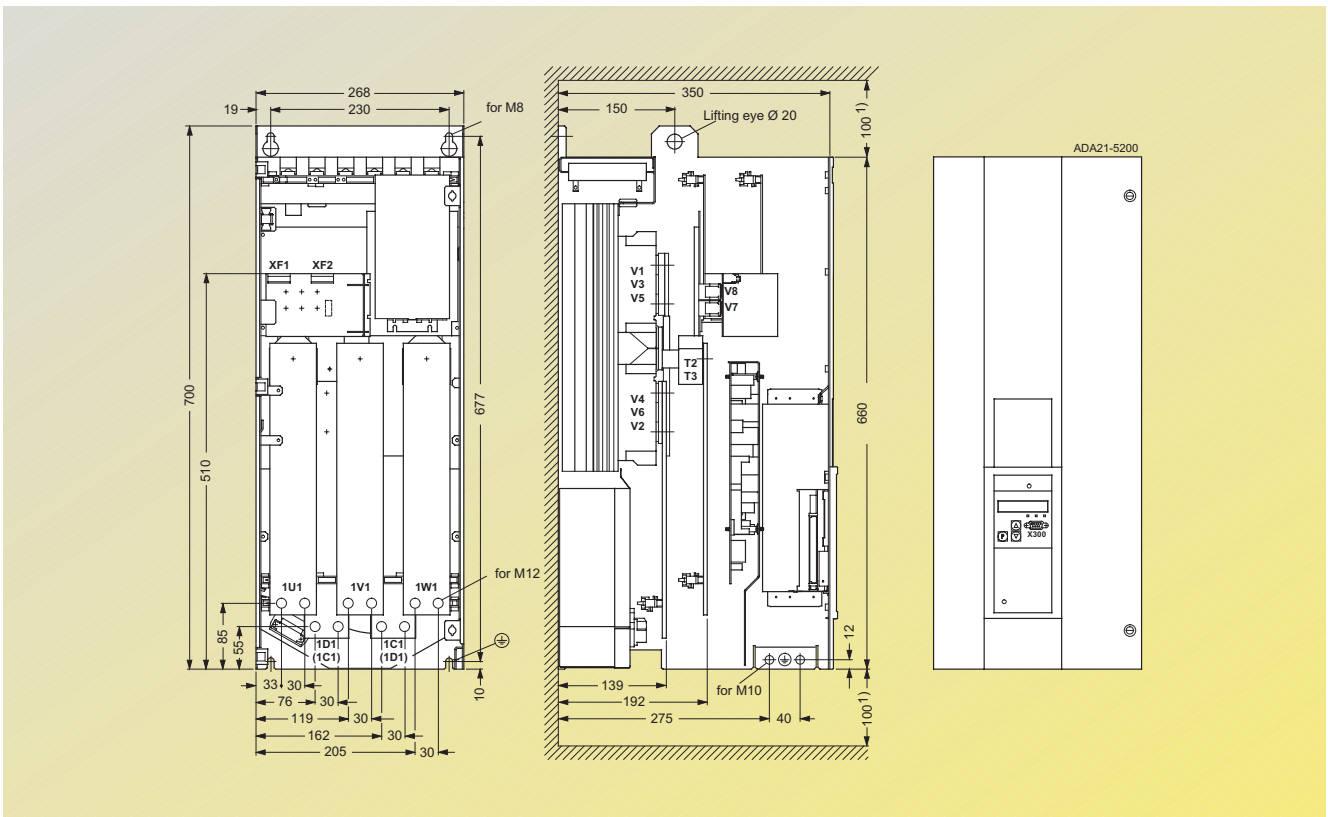
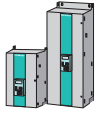

Fig. 8/11

1) Minimum free space for air circulation; it is necessary to ensure that the cooling air intake is sufficient.



SIMOREG 6RA70 DC MASTER Dimension Drawings

Converters with additional power circuit terminals on their top panel

3-ph. AC 460 V, 60 A to 125 A, 1Q

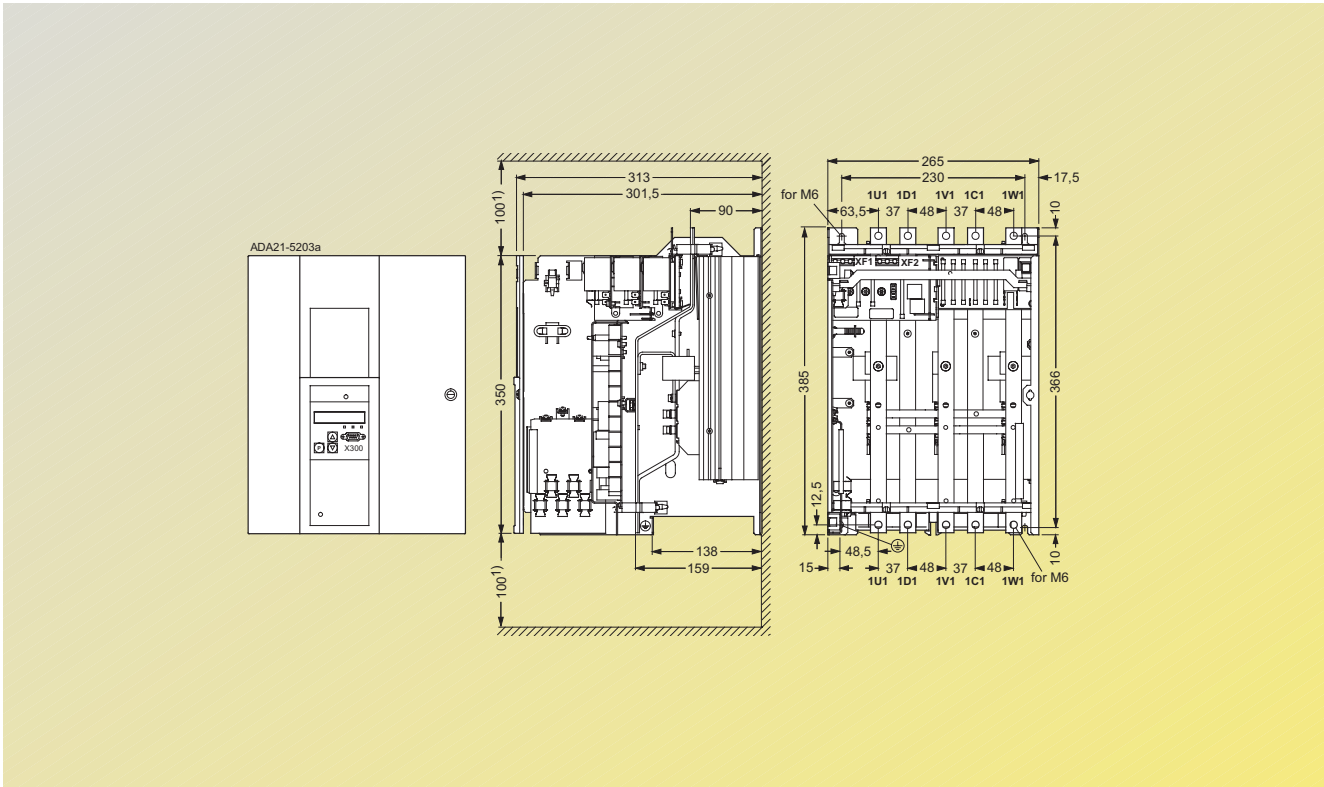

Fig. 8/14

3-ph. AC 460 V, 210 A to 280 A, 1Q

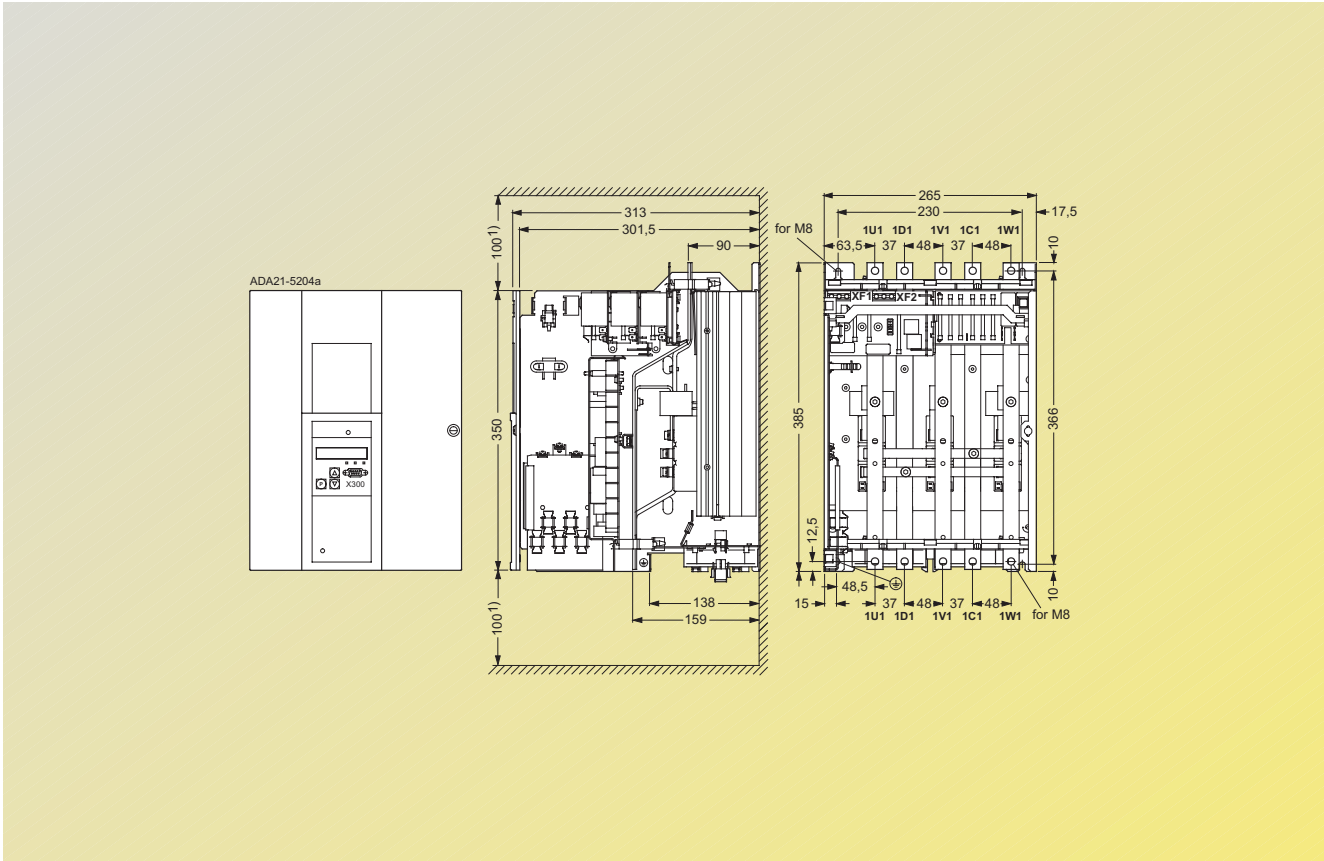
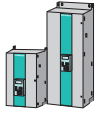

Fig. 8/15

1) Minimum free space for air circulation; it is necessary to ensure that the cooling air intake is sufficient.



SIMOREG 6RA70 DC MASTER Dimension Drawings

Converters with additional power circuit terminals on their top panel

3-ph. AC 460 V, 60 A to 125 A, 4Q

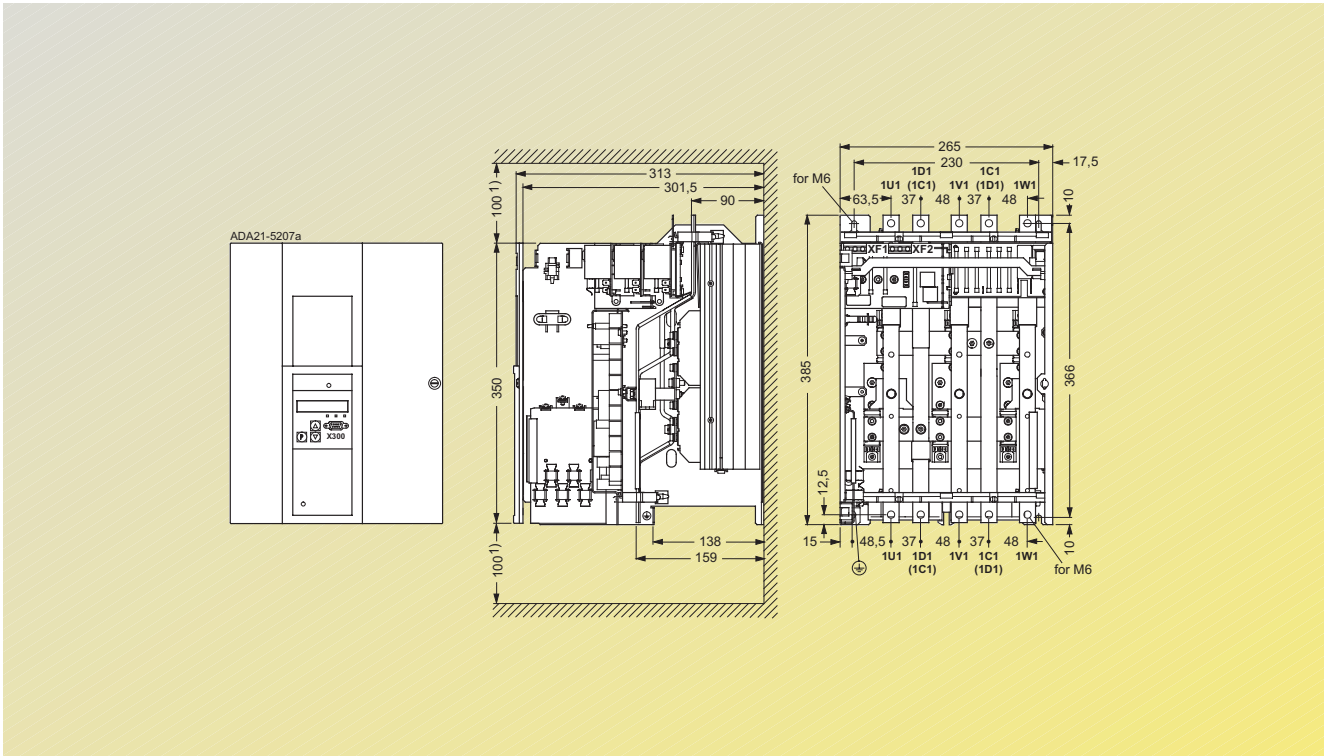

Fig. 8/18

3-ph. AC 460 V, 210 A to 280 A, 4Q

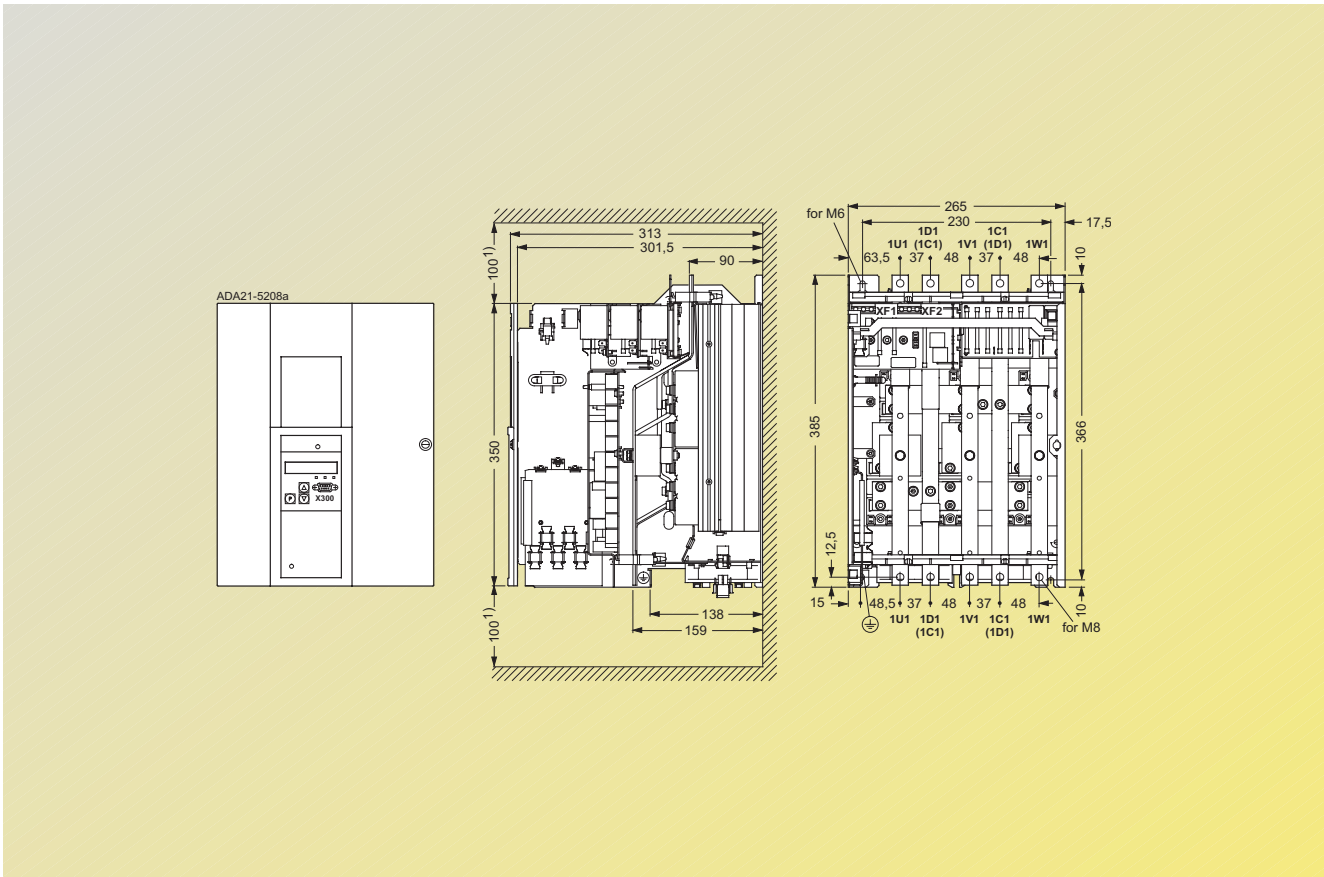

Fig. 8/19

1) Minimum free space for air circulation; it is necessary to ensure that the cooling air intake is sufficient.



SIMOREG 6RA70 DC MASTER Dimension Drawings

6RL70 rectifier module

3-ph. AC 690 V, 1000 A

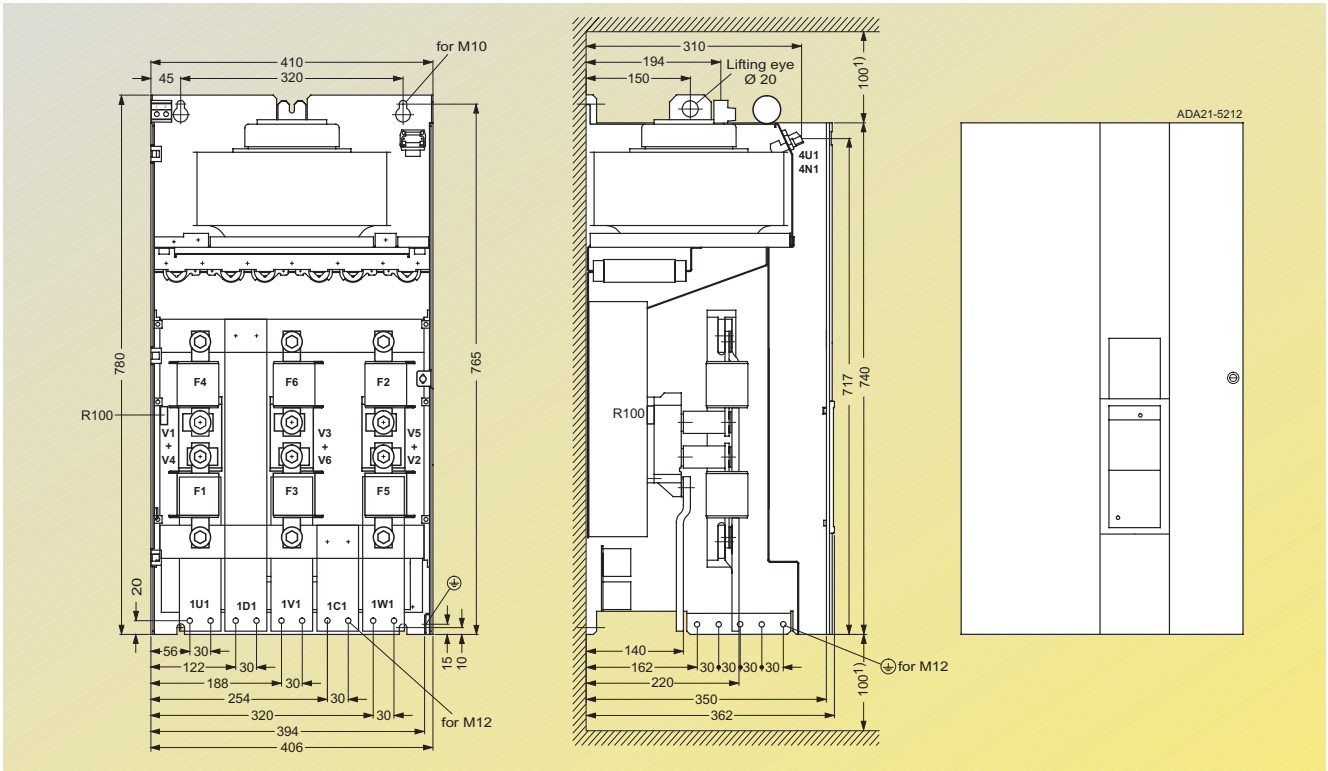

Fig. 8/22

3-ph. AC 690 V, 2000 A

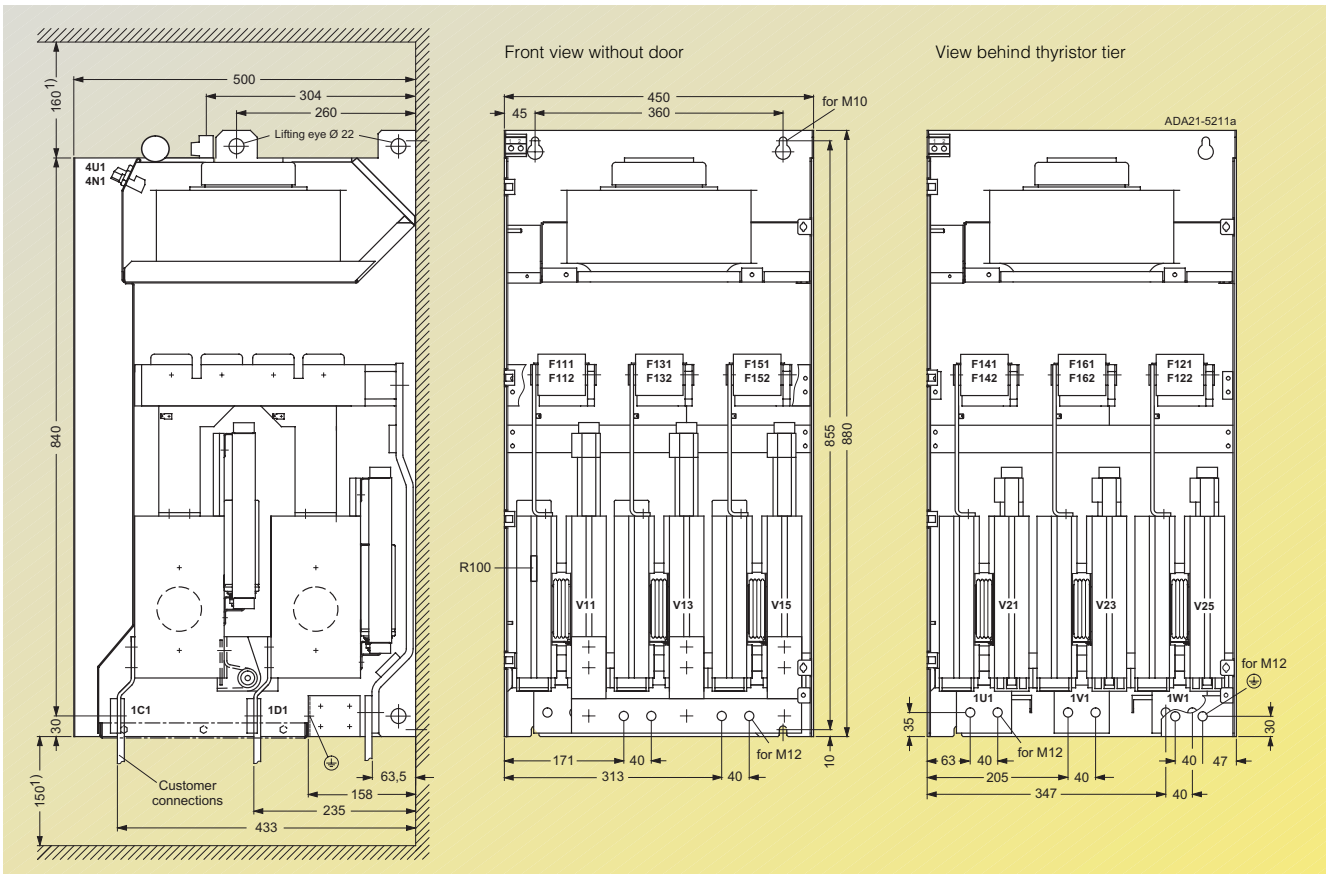

Fig. 8/23

1) Minimum free space for air circulation; it is necessary to ensure that the cooling air intake is sufficient.

SIMOREG 6RA70 DC MASTER

Dimension Drawings



SIMOREG CM

Device components assembled (as-supplied state)

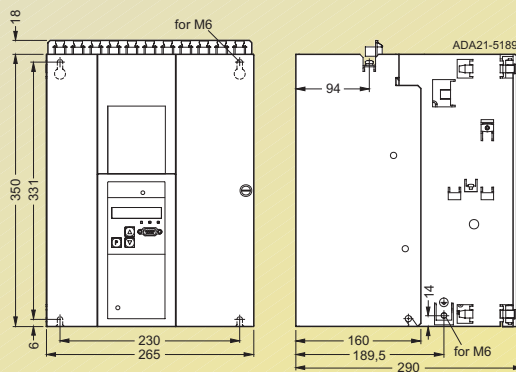

Fig. 8/24

Device components alongside each other

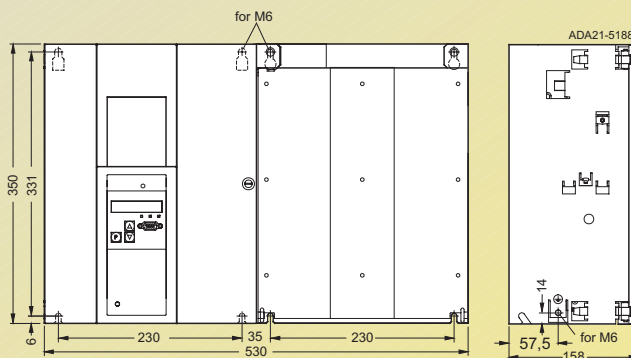

Fig. 8/25

SIMOREG 6RA70 DC MASTER

Documentation and Training



9/2
9/3
9/3

Documentation

Documentation overview
Documentation for SIMOREG units
Documentation for electronics options

9/4
9/5
9/5
9/5

Training

Training center
Training courses
Fundamentals of DC drive technology (GEI)
SIMOREG 6RA70 DC MASTER
Commissioning of DC drives (GMP5)

9/6
9/6

Demonstration model

SIMOREG DC MASTER demonstration model
Selection and ordering data

SIMOREG 6RA70 DC MASTER

Documentation and Training

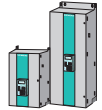

Documentation

Documentation overview

The documentation for the SIMOREG DC MASTER converters is available at three different levels:

- Description
- Operating instructions
- Documentation on CD-ROM

These types of documentation differ with regard to their content and medium (printed or on CD-ROM).

Description

The Description is supplied with every unit as a manual with the exception of the SIMOREG CM unit. The content is an excerpt from the Operating Instructions and contains the same Sections with the exception of Sections 9 (function descriptions), 11 (parameter list) and 12 (list of connectors and binectors). The Description contains the information in English and German. Versions in other languages are not available.

The Description provides the necessary product documentation (such as dimension drawings, technical data, function diagrams and descriptions of the errors and warnings). The commissioning instructions it contains supports commissioning of a unit and in addition – for the experienced user of SIMOREG DC MASTER converters – project engineering on the basis of function diagrams is possible.

Operating instructions

The Operating Instructions contain all the relevant data for the SIMOREG DC-MASTER converters. In addition to the information provided in the Description, the Operating Instructions contain the detailed function description, the extensive parameter description and the complete list of connectors and binectors. The Operating Instructions are available in five languages: English, German, French, Spanish and Italian and must be ordered separately. German Operating Instructions are supplied with the SIMOREG CM unit, other language versions must be ordered with a "Z" option.

The Operating Instructions are required when:

- Access to the parameter list is necessary
- Complex project engineering requires functions over and above the factory settings or the standard drive functions
- The dynamic overload capability of the units is to be individually utilized.

Documentation on CD-ROM

The product CD-ROM contains all the Operating Instructions for the converters and for the SIMOREG CM unit in electronic form. The files are provided in Acrobat and Winword file format.

The CD-ROM also contains the DriveMonitor for commissioning, parameter setting and diagnosis via the PC. The DriveMonitor supersedes SIMOVIS and is a component of the Drive Engineering System "Drive ES".

On the CD-ROM, there are articles about DC drive applications and implementation, on topics such as:

- Axle winders
- 12-pulse applications
- Control sequence changeover (Master Slave operation)
- SIMOREG as field supply unit
- Tips for project engineering

and more. These articles are continuously reviewed and updated.

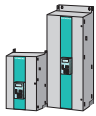

SIMOREG 6RA70 DC MASTER Documentation and Training

Documentation

Documentation for SIMOREG units

Description	Language	Code	Order No.:
SIMOREG DC MASTER operating instructions The converters are supplied with a Brief Description, Operating Instructions must be ordered.	German	D00	6RX1700-0AD00
	Italian	D72	6RX1700-0AD72
	English	D76	6RX1700-0AD76
	French	D77	6RX1700-0AD77
	Spanish	D78	6RX1700-0AD78
Operating Instructions and DriveMonitor in all the languages listed above on CD-ROM		D64	6RX1700-0AD64
SIMOREG CM operating instructions The units are supplied with German Operating Instructions as standard, other language versions must be ordered.	German	–	6RX1700-0BD00
	Italian	D72	6RX1700-0BD72
	English	D76	6RX1700-0BD76
	French	D77	6RX1700-0BD77
	Spanish	D78	6RX1700-0BD78
Operating Instructions and DriveMonitor in all the languages listed above on CD-ROM		D64	6RX1700-0BD64
SIMOREG 6RL70 operating instructions The units are supplied with Operating Instructions in five languages, English, German, French, Italian and Spanish		–	6RX1700-0CD64

Documentation for electronics options

Description	Order No.:	Description	Language	Order No.:
Communication board CBP2	6SE708 □- □NX84-0FF0	T100 technology board hardware description	E/G/Fr/Sp/It	6SE7080-0CX87-0BB0
Communication board CBC	6SE708 □- □NX84-0FG0	T400 technology board, User's Guide for T400 hardware and project engineering	–	6DD1903-0EA0
Communication board SLB	6SE708 □- □NX84-0FJ0	MS320 software module	German English	6SE7080-0CX84-2AH1 6SE7087-6CX84-2AH1
Terminal expansion board EB1	6SE708 □- □NX84-0KB0	MS340 software module	German English French	6SE7080-0CX84-4AH1 6SE7087-6CX84-4AH1 6SE7087-7CX84-4AH1
Terminal expansion board EB2	6SE708 □- □NX84-0KC0	MS360 software module	German English	6SE7080-0CX84-6AH1 6SE7087-6CX84-6AH1
Pulse encoder evaluation board SBP	6SE708 □- □NX84-0FA0	MS380 software module	German English	6SE7080-0CX84-8AH1 6SE7087-6CX84-8AH1
German/English	7 6	MS100 software module Universal drive for T100	German English French Spanish Italian	6SE7080-0CX84-0BB1 6SE7087-6CX84-0BB1 6SE7087-7CX84-0BB1 6SE7087-8CX84-0BB1 6SE7087-2CX84-0BB1
Italian/English	7 2	Safe Sensor Board SSB	E/G/Fr/Sp/It	6SE7080-0AX87-1JB0
French/English	7 7	SCB1, SCI1 and SCI2 interface boards		6SE708 □- □CX84-0BC0
Spanish/English	7 8	German/English		7 6
Japanese	8 0	Italian		7 2
		French		7 7
		Spanish		7 8

SIMOREG 6RA70 DC MASTER

Documentation and Training

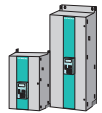

Training

Training center

The training center has branches throughout the world and offers the full range of courses presented in the training program for SIMOREG DC MASTER converters. Courses are also offered for the complete spectrum of the world of automation and drives. Individual tailoring of the course content and training at the customer site is possible.

With – SIBRAIN – the innovative concept for imparting knowledge at all levels, the Training Center offers a comprehensive service for qualification of personnel. From the standard course through to individually tailored training courses and workshops, know-how to suit all requirements can be acquired:

- Technical know-how for automation, drive technology, power engineering, instrumentation, industrial IT, electronics and mechanical engineering
- Method know-how for systematic fault diagnosis, project management and maintenance management
- Process know-how for sector-specific automation processes, for example in rolling mills, breweries, cement, sugar and paper.

Central office:

Siemens I&S IS INA
Training Center
Course Office
Werner-von-Siemens-Str. 65
D-91052 Erlangen
Tel.:
+49 (0)9131-7-28566
Fax:
+49 (0)9131-7-28172

You will find Information about the courses on the Internet at:
<http://info-tc.erlm.siemens.de>

You can contact the Training Center via e-mail at the following address:
sibrain@erl9.siemens.de



Fig. 9/1

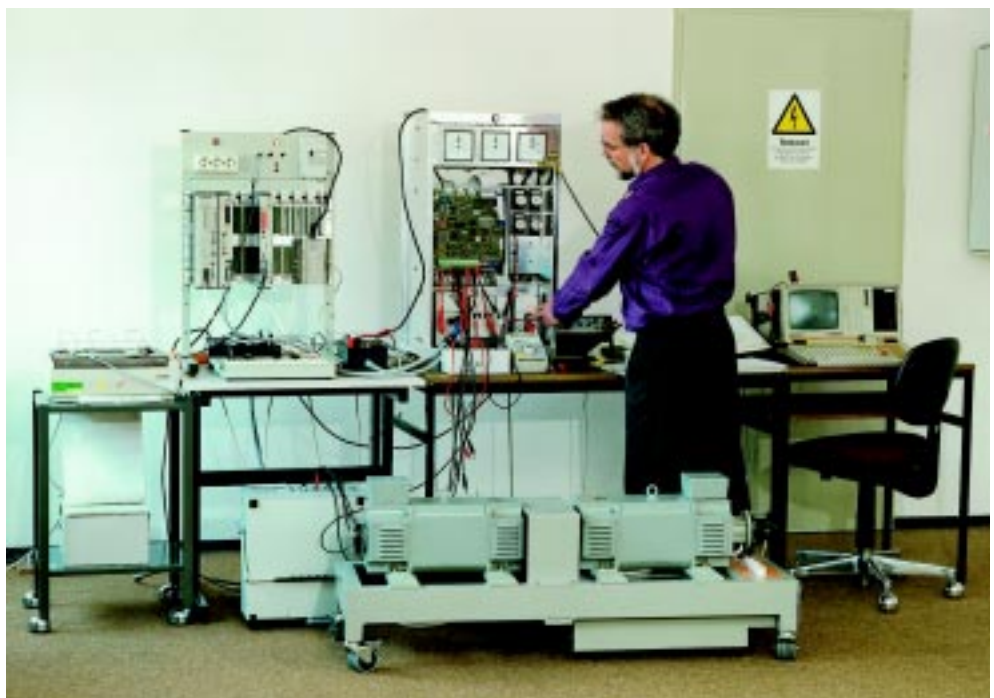
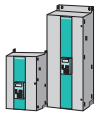

Fig. 9/2



Training courses

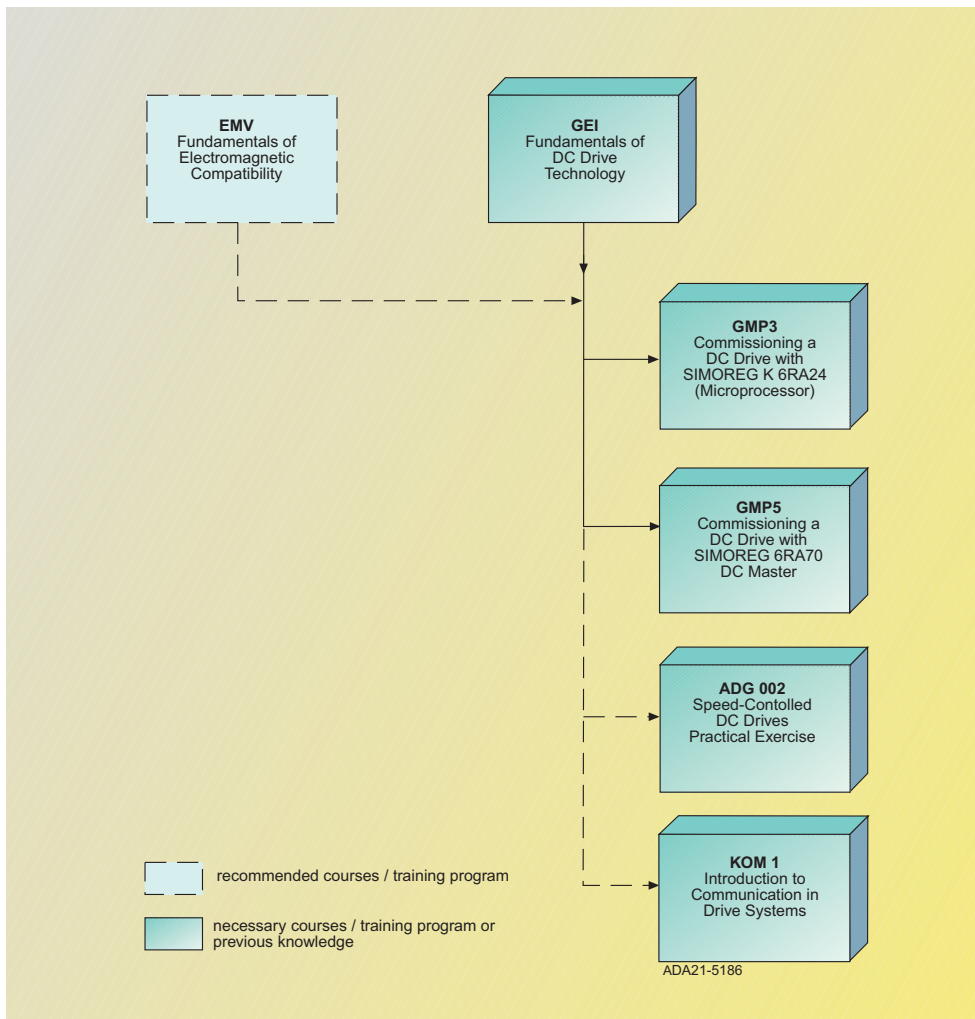

Fig. 9/3
Training program

SIMOREG 6RA70 DC MASTER Commissioning of DC drives (GMP5)

Target group

Customers and Siemens personnel who have to commission and maintain digital closed-loop control DC drives for the 6RA70 Series.

Learning targets

Participants shall understand the functions of a converter unit and the serial interfaces. They will be able to start up the unit, modify the parameters on a machine and document them as well as detecting and rectifying errors.

Requirements

An understanding of the DC machine and converter and closed-loop control technology as obtained from basic course GEI.

Content

- Presentation of the design of the SIMOREG DC-MASTER series
- Explanation of the mode of operation
- Explanation of the function diagrams
- Commissioning, parameterization and control loop optimization including checking of operation
- Explanation of the operating states, error handling, analog and binary inputs and outputs by means of practical examples
- The implementation of the DriveMonitor and OP1S with
 - Data transfer, data backup
 - Use of the trace buffer
 - Commissioning
- Peer-to-peer and SIMOLINK connections
- Examples of “freely-defined functions”
- Practical training and “troubleshooting”.

Fundamentals of DC drive technology (GEI)

Target group

Customers and Siemens personnel who have to commission and maintain analog closed-loop control DC drives.

Learning targets

Participants will be able to commission a DC drive with a converter, understand the converter circuit, recognize the closed-loop control structure and optimize the control loop.

Requirements

Basic electrical engineering know-how in accordance with specialist training.

Content

Explanation of the functioning of:

- DC motors
- Thyristors
- Converter circuits
- Closed-loop control circuits

Explanation of the system components and control structures of a thyristor-controlled DC drive.

Familiarization with the methods for determining the parameters of the controlled systems.

Explanation of the individual optimization steps and practical training

- on a training model
- using digital simulation techniques

Note

The knowledge gained in this course is a precondition for the more advanced courses such as GMP3 and GMP5.

SIMOREG 6RA70 DC MASTER

Documentation and Training



Demonstration model

SIMOREG DC MASTER demonstration model

Portable demonstration models are available for SIMOREG 6RA70 DC MASTER converters.

Field of application

- Presentation of Siemens DC drives to customers
- Familiarization of Siemens personnel in the Regional Offices and National Companies
- Training of customers
- Test set-ups with PROFIBUS-DP

Design

The SIMOREG DC MASTER demonstration model comprises 2 cases.

A Brief Description is supplied with the demonstration cases. The Brief Description explains the basic layout of the control panel and the possible functions of the respective control elements.

An automation network can be implemented with the SIMATIC demonstration case in combination with one or more SIMOREG DC MASTER and/or SIMOVERT MASTERDRIVES demonstration cases (SIMOVERT demonstration case MASTERDRIVES CUV Order No. 6SX7000-0AC01).

A mobile trolley can be ordered to make it easier to transport the demonstration cases.

Mains connection

The equipment is connected to the mains via a 16 A CECON plug (5UR5076-3) with a cable of approximately 3 m in length.

The supply voltage for the selected SIMOREG unit is 3-ph. AC 400 V (+15% / -20%) and the rated frequency is 45 to 65 Hz.



Fig. 9/4
SIMOREG DC MASTER demonstration case and DC motor demonstration case

Design

The demonstration cases are fully assembled and contain all the necessary wiring, connecting cables and signal leads.

Operation

The converter can be operated by means of

- The CBP interface for the PROFIBUS-DP automation network
- The terminals to which the operator panel is connected.

The demonstration unit is supplied ready for operation from the control panel.

Parts list

Each SIMOREG DC MASTER demonstration case contains the following main components:

Description	Type
1 x SIMOREG 15-A unit, 3-ph. AC 400 V/4Q	6RA7013-6DV62-0-Z Z = S00+D00+D64
1 x CBP communication board	6SE7090-0XX84-0FF0
1 x LBA bus adapter for the electronics box	6SE7090-0XX84-4HA0
1 x ADB carrier module	6SE7090-0XX84-0KA0
1 x B1 radio interference suppression filter	6SE7021-0ES87-0FB0
1 x three-phase commutating reactor	4EP3601-3DB
1 x single-phase commutating reactor	4EP4807-1CB
1 x control-power transformer 400/24 V	4AM8041-5AN08-0B

The DC motor demonstration case contains:

Description	Type
1 x DC motor 1.85 kW, 3120 rpm, with 2 pulse encoders 1024 pulses per revolution.	1GA5100-0BE40-6VE0-Z Z = H55

Selection and ordering data

Description	Order No.:
SIMOREG DC MASTER 6RA70 demonstration case	6RX1700-0SV00
Demonstration case containing 1GA51.. DC motor	6RX1240-0MV00
Mobile trolley for both demonstration cases	6SX7000-0AE01

SIMOREG 6RA70 DC MASTER

Appendix

A/2	Environment, resources and recycling
A/3	Certificates
A/4	Subject index
A/5	Order number index
A/6	Abbreviations
A/7	Siemens companies and representatives inside Europe
A/8	Siemens companies and representatives outside Europe
A/10	Information and ordering on the Internet and on CD-ROM
A/11	Customer support
A/14	Conditions of sale and delivery, export regulations

SIMOREG 6RA70 DC MASTER

Appendix

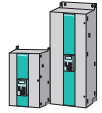

Environment, resources and recycling

Siemens AG has committed itself to protecting the environment and conserving valuable natural resources. This applies both to production and to the products we sell.

As early as the development phase, the possible impact of future products and systems on the environment is taken into consideration. Our aim is to prevent environmental pollution or, at least, reduce it to a minimum and, in doing so, look beyond existing regulations and legislation.

Environmental aspects of development

The use of dangerous substances (such as arsenic, asbestos, beryllium, cadmium, CFC, halogens and many others) has already been avoided in the development stage.

Easily dismantled joints have been designed and attention has been paid to increased uniformity of types and grades of materials.

Furthermore, recyclable materials have been given priority, or materials which can be disposed of without any problems.

The number of components has been significantly reduced by using large-scale integrated components and due to the modular design of the complete converter range. This reduces the energy consumed during production. Particular attention is paid to reducing the volume, mass and range of types of the metal and plastic components.

Flame resistant materials containing halogen and insulation materials containing silicon have been replaced in all the main components with neutral materials.

Environmental aspects were an important criteria in selecting the supplied components.

Environmental aspects of manufacturing

The supplied components are mainly transported in reusable packaging. The packaging material itself is reusable, mainly comprising cardboard.

With the exception of the housing, surface coatings are not used.

The manufacturing facility produces no emissions.

Materials for manufacturing purposes are identified in accordance with their recyclability. This applies, in particular, to components which contain unavoidable, hazardous materials. These components are installed or mounted in such a way that they can be easily separated, thus facilitating disposal in an environmentally-friendly manner. Wherever possible, recycled components are used.

Despatch

Environmentally-compatible packaging materials are used for shipping and storage. If possible we pack our products in reusable packaging.

Environmental aspects of disposal

The unit can be disassembled into recyclable mechanical components by means of easily removed screw and snap-on fixings.

The boards can be sent for thermal recycling. The proportion of components that contain dangerous substances is minimal.

We have already made preparations to enable the converters to be disposed of after use in accordance with the regulations governing the disposal of electronic equipment (not yet in force).

This catalog is printed on Chlorine-free bleached paper.

Front components	PC + ABS ABS	Cycoloy Novodur	GE Plastics Bayer
Plastic components in the unit	PC PA 6.6 SE1-GFN1	Lexan 141-R Noryl	
Insulation	PC (FR) fl	Makrolon or Lexan	
Keypad membrane	Polyester film 0.15 mm		
Rating plate	Polyester film		

SIMOREG 6RA70 DC MASTER

Appendix



Subject index

	Page		Page
12-pulse operation	5/18		
A		G	
Actual speed value	2/6	Gating unit	2/7, 2/8
Adapter AOP1	7/6	General technical data	3/2
Adapter board ADB	4/8, 7/4	H	
Air-flow monitoring in motor fan	2/12	Harmonics	5/26
Analog outputs	2/9	I	
Analog selectable inputs	2/9	Installation of electronics options	4/7
Auto-reversing module	2/7	Instructions for the electromagnetically compatible installation of drives	5/20
B		Integration of the electronics options	4/6
Backplane bus adapter LBA	4/8	Interface board SCB1	4/35
BICO data sets	2/5	Interface boards SCI1 and SCI2	4/15, 7/5
Binary inputs	2/10	Interface converter	7/6
Binary outputs	2/10	Interface to motor	2/12
Binectors	2/5	L	
Bridging kit	7/5	LBA	4/8, 7/6
Brush length monitoring	2/12	Level of input pulses:	5/19
C		Load cycles for 1Q applications	5/15
Cabinet arrangement and shielding	5/22	Load cycles for 4Q applications	5/16
Cable, cable length, shield connection	5/19	M	
Calculation of dynamic overload capability	5/2	Mobile trolley	9/6
CAN communication board CBC	4/32	Monitoring and diagnosis	2/8
CBC	4/32, 7/4	Motorized potentiometer	2/5
CBD	4/34, 7/4	Motor temperature monitoring	2/12
CBP2	4/30, 7/4	MS100	7/4
Certificates	A/3	O	
Characteristic data of pulse evaluation electronics	5/19	OP1S	2/3, 4/36
Closed-loop field current control	2/8	Open-loop and closed-loop control section	2/14
Closed-loop functions in armature circuit	2/6	Operating instructions	7/6, 9/2
Closed-loop functions in field circuit	2/8	Operation and monitoring	4/36, 7/6
Communication	4/27	Operation and parameterization unit	2/3
Communication board CBC	4/32	Operator control panel OP1S	2/3, 4/36
Communication board CBD DeviceNet	4/34	Optimization run	2/8
Communication board CBP2	4/30	Optional board SBP for pulse encoder	4/9
Communication board SLB	4/28	Options in the basic unit	4/2
Commutating reactors	5/24	P	
Components for the converters	5/23	Parallel connection	5/17
Condensation protection	5/18	Parallel connection of SIMOREG DC MASTER converters	5/17
Connecting cable	7/6	Parameterization devices	2/3
Connectors	2/5	Peer-to-peer protocol	2/11
Control Module SIMOREG CM	7/3	Performance options	4/42
Control terminal block	2/12	PMU	2/3
Converter operator panel OP1S	2/3	Power section and cooling	2/2
Converters for four-quadrant operation	3/13	PROFIBUS-DP communication board CBP2	4/30
Converters for single-quadrant operation	3/3	Pulse encoder evaluation SBP	4/9, 7/4
CUD1	2/14	R	
CUD2	4/3, 7/4	Radio interference suppression filter	5/25
Current controller	2/7	Ramp-function generator	2/6
Current limitation	2/7	Rating classes	5/14
D		Rectifier module SIMOREG 6RL70	4/42, 7/6
Demonstration cases	9/6	Redundancy mode	5/17
Demonstration model	9/6		
Design and mode of operation	2/5		
DeviceNet	4/34, 7/4		
Dimension drawings	8/1		
Documentation	7/6, 9/2		
Drive ES	4/39		
Drive ES engineering package	4/39		
DriveMonitor	4/38		
Dynamic overload capability	5/2		
E			
EB1	4/11, 7/4		
EB2	4/13, 7/4		
Electromagnetically compatible installation	5/21		
Electronics options	7/4		
E.m.f. controller	2/8		
Environment and recycling	A/3		
Error messages	2/9		
E-STOP	2/11		
F			
Feedforward control function	2/7		
Functions of inputs and outputs	2/9		
Fundamentals of EMC	5/20		

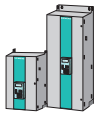

SIMOREG 6RA70 DC MASTER

Appendix

Subject index,
order number index

	Page		Page
S		4E	
Safety shutdown (E-STOP)	2/11	4EM	5/24
SBP	4/9	4EP	5/24
SCB1	4/35	4EU	5/24
SCI1	4/15	6DD	
SCI2	4/15	6DD16	4/23, 7/4
Selection and ordering data	7/1	6DD18	4/23
Serial interfaces	2/11	6DD19	4/23, 7/4
Service and support	A/12	6RA	
SIMOLINK communication board SLB	4/28	6RA70	7/2, 7/3
SIMOREG CM	6/1, 7/3	6RL	
SIMOREG DC-Master with fan	2/19	6RL70	7/6, 9/3
SIMOREG DC-Master without fan	2/18	6RX	
SIMOREG 6RL70 rectifier module	4/42	6RX1240-0MV0	9/6
Simple operator panel PMU	2/3	6RX1700-0AD..	7/6, 9/3
Single-phase commutating reactors	5/24	6RX1700-0AK00	4/3, 7/4
SLB	4/28	6RX1700-0AS00	4/2, 7/4
Software modules	4/2	6RX1700-0BD..	7/6, 9/3
Software structure	2/5	6RX1700-0CD64	7/6, 9/3
Software update service for Drive ES	4/41	6RX1700-0SV00	9/6
Speed controller	2/6	6RY	
Speed setpoint	2/6	6RY1707	6/6, 7/5
Supplying high inductances	5/18	6RY1707-0AA08	7/4
Switching frequency	5/19	6SE	
T		6SE7008.-CX84	9/3
Technical data	3/1	6SE7008.-NX84	9/3
Technology board T100	4/24, 7/4	6SE7021-0ES87-0FB1	5/25
Technology board T300	4/26, 7/4	6SE7021-8ES87-0FB1	5/25
Technology board T400	4/19, 7/4	6SE7023-4ES87-0FB1	5/25
Technology controller	4/2	6SE7027-2ES87-0FB1	5/25
Technology software	4/2, 7/4	6SE7031-2ES87-0FA1	5/25
Terminal assignment	2/13, 2/15	6SE7031-8ES87-0FA0	5/25
Terminal connections for parallel connection	5/17	6SE7033-2ES87-0FA1	5/25
Terminal expansion board CUD2	4/3, 7/4	6SE7036-0ES87-0FA1	5/25
Terminal expansion board EB1	4/11	6SE7041-0ES87-0FA1	5/25
Terminal expansion board EB2	4/13	6SE7041-6ES87-0FB1	5/25
Terminal expansions	4/9	6SE7080-0CX84-0BB1	7/4
Three-phase commutating reactors	5/24	6SE7080-0CX87-0BB0	7/4
Torque limitation	2/7	6SE7087-2CX84-0BB1	7/4
Trace function	2/8	6SE7087-6CX84-0BB1	7/4
Training	9/4	6SE7087-7CX84-0BB1	7/4
Training Center	9/4	6SE7087-8CX84-0BB1	7/4
U		6SE7090-0XX84-0AH2	4/26
USS protocol	2/11	6SE7090-0XX84-0BC0	4/35, 7/4
W		6SE7090-0XX84-0KA0	4/8, 7/4
Warnings	2/9	6SE7090-0XX84-2FK0	7/6
		6SE7090-0XX84-3EA0	4/18, 7/5
		6SE7090-0XX84-3EF0	4/18, 7/5
		6SE7090-0XX84-4HA0	4/8, 7/4
		6SE7090-0XX87-0BB0	4/25, 7/4
		6SE7090-0XX87-4AH0	4/26, 7/4
		6SE7098-0XX84-0BB0	7/4
		6SE7972-0BB40-0XA0	4/31
		6SW	
		6SW1700	4/41
		6SX	
		6SX7000-0AE01	9/6
		6SX7005-0AA00	7/6
		6SX7005-0AB00	7/6
		6SX7010-0AA00	4/37, 7/6
		6SX7010-0AB03	7/6
		6SX7010-0AB05	4/37, 7/6
		6SX7010-0AB63	4/37
		6SX7010-0FA00	4/10, 7/4
		6SX7010-0FF05	4/31, 7/4
		6SX7010-0FG00	4/33, 7/4
		6SX7010-0FJ00	4/29, 7/4
		6SX7010-0FJ50	4/29
		6SX7010-0FK00	4/34, 7/4
		6SX7010-0KB00	4/12, 7/4
		6SX7010-0KC00	4/14, 7/4
		6SX7090-0XX84-2FK0	4/37
		6SY	
		6SY7000-0AD15	4/29
		6XV	
		6XV1830-0AH10	4/31
		B	
		B84143	5/25

SIMOREG 6RA70 DC MASTER

Appendix

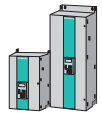

Abbreviations

A		O	
ADB	Carrier for small-format supplementary boards (Adapter Board)	OP1S	Optional control panel with plain text display and internal memory for parameter sets (Operator Panel 1 / Store)
C		P	
CAN	Fieldbus specification for the CiA user organization (CAN in Automation) (Controller Area Network)	PDO	Process Data Object (CAN bus)
CAL	CAN Application Layer	PKE	Parameterkennung
CB	Supplementary board for communication (Communication Board)	PKW	Related to a parameter (Parameter-Kennung-Wert)
CBC	Supplementary board for CAN bus coupling (Communication Board CAN-Bus)	PMU	Simple control panel for the SIMOREG DC-MASTERS (Parameterization Unit)
CBD	Supplementary board for DeviceNet interfacing (Communication Board DeviceNet)	PNU	ParameterNUmber
CBP2	Supplementary board for PROFIBUS-DP interfacing (Communication Board PROFIBUS)	PPO	Definition of number of parameter and process data words for PROFIBUS-DP communication (Parameter Process data Object)
COB	Communication Object with CAN bus communication	PROFIBUS-DP	Fieldbus specification of the PROFIBUS-DP association (Process Field Bus)
CUD1	Electronics module C98043-A7001 for SIMOREG DC-MASTER (Control Unit / Direct Current)	PWE	Parameterwert
CUD2	Terminal expansion board C98043-A7006 for CUD1	PZD	Prozessdaten
D		S	
DeviceNet	Fieldbus specification of ODVA (Open DeviceNet Vendor Association)	SBP	Supplementary board for tacho interfacing (Sensor Board Pulse)
DP	Dezentrale Peripherie	SCB1	Supplementary board for interfacing from SCI1 or SCI2 via fiber-optic cable (Serial Communication Board 1)
E		SCI1	Supplementary board with additional inputs/outputs; I/O slave module on SCB1 (Serial Communication Interface 1)
EB1	Supplementary board with additional inputs/outputs (Expansion Board 1)	SCI2	Supplementary board with additional inputs/outputs; I/O slave module on SCB1 (Serial Communication Interface 2)
EB2	Supplementary board with additional inputs/outputs (Expansion Board 2)	SDO	Service Data Object (CAN bus)
G		SIMOLINK	Fieldbus specification for fiber-optic ring bus (Siemens Motion Link)
GSD file	Geräte-Stammdaten file containing a definition of the communication characteristics of the communication boards for PROFIBUS-DP	SLB	Supplementary board for SIMOLINK interfacing (SIMOLINK Board)
I		STW	Steuerwort
ID	Identifier for CAN bus communication	T	
IND	Parameter Index	T100	Supplementary board with technology functions (Technology Board 100)
L		T300	Supplementary board with technology functions (Technology Board 300)
LBA	Backplane wiring for the installation of supplementary modules (Local Bus Adapter)	T400	Supplementary board with technology functions (Technology Board 400)
M		TB	Technologiebaugruppe T100, T300 or T400
MSAC_C1	Designation of a transmission channel for PROFIBUS-DP (Master Slave Acyclic / Class 1)	U	
MSCY_C1	Designation of a transmission channel for PROFIBUS-DP (Master Slave Cyclic / Class 1)	USS	Universelle serielle Schnittstelle
		Z	
		ZSW	Zustandswort (status word)

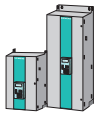

SIMOREG 6RA70 DC MASTER

Appendix

Siemens companies and representatives
inside Europe

Albania

BINDI sh. p. k.
Tirana

Armenia

Representative of Siemens AG
Yerevan

Austria

Siemens AG Österreich
Vienna
Bregenz
Deutschlandsberg
Eisenstadt
Graz
Innsbruck
Klagenfurt
Klosterneuburg
Linz
Salzburg
St. Pölten
Villach

Azerbaijan

Representative of SIMKO AS
Baku

Belarus

Representative of Siemens AG
Minsk

Belgium

Siemens S. A.
Brussels
Antwerpen
Boussu
Coffontaine
Dilsen-Stokkem
Gent
Haasrode
Herentals
Huizingen
Liège
Namur
Oostkamp
Zaventem

Bulgaria

Siemens AG Representative in Bulgaria
Sofia

Croatia

Siemens d.d.
Zagreb

Cyprus

GEVO Ltd.
Nicosia

Czech Republic

Siemens s.r.o.
Prague
Brno
Děčín
Stříbro
Trutnov

Denmark

Siemens A/S
Ballerup
Alborg
Brønshøj
Esbjerg
Hedensted
Højbjerg
Odense
Skensved
Tåstrup
Veje

Eire (Ireland)

Siemens Ltd.
Dublin

Estonia

AS Siemens
Tallinn

Finland

Siemens
Osakeyhtiö
Espoo
Helsinki

France

Siemens S. A. S.
Saint-Denis
Bihorel
Caluire-et-Cuire
Cesson Sévigné
Dijon
Haguenau
La Garenne Colombes
La-Suze-sur-Sarthe
Lesquin
Les Ulis
Lissess
Lormont
Marseille
Mérignac
Metz
Montrouge
Molsheim
Nanterre
Nantes
Nice
Pantin
Paris La Défense
Reims
Saint-Denis
Saint-Quentin
Strasbourg
Toulouse

Georgia

Representative of Siemens AG
Tbilisi

Great Britain

Siemens plc
Bracknell
Beeston
Belfast
Bellshill
Birmingham
Bristol
Camberley
Cambridge
Chessington
Christchurch
Clevedon
Corby
Congleton
Crawley
Cumbernauld
East Kilbride
Fareham
Glasgow
Hemel Hempstead
Hounslow
Ilford
Isle of Wight
London
Luton
Manchester
Milton Keynes
Newcastle-upon-Tyne
Oldham
Oxford
Poole
Purley
Romsey
Telford
Wellingborough
Wembley

Greece

Siemens A. E.
Athen, Amaroussio
Acharnes
Thessaloniki
Vassiliko Evias

Hungary

Siemens Rt.
Budapest
Bicske
Cegléd
Szombathely

Iceland

Smith & Nordland HF
Reykjavik

Italy

Siemens S. p. A.
Milano
Bari
Bologna
Brescia
Cagliari
Casoria
Cassina de Pecchi
Fanglia
Firenze
Genova
Napoli
Padova
Palermo
Pescara
Roma
Torino
Verona

Latvia

Siemens S/A
Riga

Lithuania

Lietuvos ELTIKA
Vilnius
Klaipeda

Luxembourg

Siemens S. A.
Luxembourg-Hamm

Macedonia

SITAI d.o.o.
Skopje

Malta

J.R.D. SYSTEMS Ltd.
Harun

Moldavia

Siemens s.r.l.
Chisinau

Netherlands

Siemens Nederland N. V.
Den Haag
Alphen a/d Rijn
Zoetermeer

Norway

Siemens A/S
Oslo
Fyllingsdalen
Trondheim

Poland

Siemens Sp.z.o.o.
Warsaw
Gdańsk-Wrzeszcz
Katowice
Kratów
Poznań
Wroclaw

Portugal

Siemens S. A.
Lisbon
Amadora
Albufeira
Carnaxide
Coimbra
Evora
Loures
Matosinhos Codex
Mem Martins
Seixal

Romania

Siemens birou de consultații tehnice
Bucharest
Satina

Russia

Siemens GmbH Moskau
Moscow
Barnaul
Jakutsk
Yekaterinburg
Irkutsk
Yshewsk
Kaluga
Krasnodar
Novosibirsk
Perm
St. Petersburg
Tbilisi
Tjumen
Tomsk
Ufa
Vladivostok

Slovak Republic

Siemens s.r.o.
Bratislava
Dolný Kubín
Horná Streda
Michalovce
Nitra
Nové Zámky
Trnava

Slowenia

Siemens d.o.o.
Ljubljana
Kranj
Maribor

Spain

Siemens S. A.
Bilbao
Cornellá de Llobregat
Gijón
La Coruña
Las Palmas de Gran Canaria
Leon
Málaga
Murcia
Palma de Mallorca
Santa Cruz de Tenerife
Sevilla
Tres Cantos (Madrid)
Valencia
Valladolid
Vigo
Zaragoza

Sweden

Siemens AB
Upplands Väsby
Göteborg
Haninge
Jönköping
Kista
Malmö
Solna
Sundsvall

Switzerland

Siemens Schweiz AG
Zürich
Adliswil
Basel
Bioggio
Bronschhofen
Dieltikon-Fahrweid
Fahrweid
Winterthur-Töss

Turkey

SIMKO Ticaret ve Sanayi A.S.
Findikli Istanbul
Adana
Alsancak-Izmir
Ayazag-Istanbul
Beşiktaş-Istanbul
Bursa
Cerkezköy-Tekirdag
Kartal-Istanbul
Kavaklıdere-Ankara
Mecidiyeköy-Istanbul
Mudanya
Samsun

Ukraine

Representative of Siemens AG
Kiev
Charkiw
Odessa
Wischgorod

Yugoslavia

Siemens d.o.o.
Beograd

SIMOREG 6RA70 DC MASTER

Appendix

Siemens companies and representatives outside Europe



Africa

Algeria

Siemens Bureau d'Alger
Hydra

Angola

Escritório de Representação da Siemens em Angola
Luanda

Botswana

Siemens (Pty) Ltd.
Gaborone
Iwaneng

Congo

SOFAMATEL S.P.R.L.
Kinshasa

Côte d'Ivoire

Siemens AG
S.A.R.L.
Abidjan

Egypt

Siemens Limited
Cairo-Mohandessin
Smouha Alexandria

Centech
Cairo-Zamalek

Ethiopia

Siemens (Pvt)
Addis Abeba

Ghana

Impromex ACCRA
Accra

Guinea

André & Cie. S. A.
Lausanne

Kenya

Siemens Communications Ltd.
Nairobi

Lesotho

Range Telecommunication Systems (Pty) Ltd.
Maseru

Libya

Siemens A. G. Branch Libya
Tripoli

Malawi

Ecoelectric Ltd.
Blantyre

Mauritius

Ireland Blyth Ltd
Port Louis

Morocco

SETEL
Société Electrotechnique
et de Télécommunication S. A.
Casablanca

Mosambique

Siemens Limitada
Maputo

Namibia

Siemens (Pty.) Ltd.
Windhoek

Nigeria

Siemens Limited
Lagos
Abuja
Kaduna

Republic of South Africa

Siemens Ltd.
Halfway House
Centurion
Isando
Pretoria
Springs
Woodmead

Sudan

National Electrical
Commercial Co.
Khartoum

Swaziland

Siemens (Pty) Ltd
Matsapha

Tanzania

Tanzania Electrical Services Ltd.
Dar-es-Salaam

Tunesia

Siemens Bureau de Liaison
Tunis

Zambia

Siemens (Z) Ltd.
Kitwe
Lusaka

Zimbabwe

Siemens (Pvt.) Ltd.
Harare
Alexandra Park

America

Argentina

Siemens S. A.
Buenos Aires
San Martin
Bahia Blanca
Córdoba
Las Heras
Mar del Plata
Rosario
Boulogne sur Mer

Bolivia

Sociedad Comercial é Industrial Hansa Ltda.
La Paz

Brazil

Siemens Ltda.
Sao Paulo
Belo Horizonte
Brasilia
Campinas
Curitiba
Florianópolis
Fortaleza
Fravatai
Jaboatão dos Guararapes
Jundiaí
Manaus
Pôrto Alegre
Ribeirão Preto
Rio de Janeiro
Salto
Salvador
S. Bernardo do Campo
Vila Sao Joao

Canada

Siemens Canada Limited
Mississauga
Ajax
Brampton
Burnaby
Calgary
Cambridge
Dartmouth
Drummondville
Edmonton
Kanata
London
Moncton
Montreal
Mount Pearl
Ottawa
Pointe Claire
Sackatoon
Sherbrooke
Tilbury
Vanier
Windsor
Winnipeg

Chile

Siemens S.A.
Santiago de Chile

Colombia

Siemens S. A.
Santafé de Bogotá
Barranquilla
Cali-Occidente
Medellin

Costa Rica

Siemens S. A.
San José

Cuba

EUMEDA
Representación Consultiva de Siemens
Electromedicina
Ciudad de la Habana

Curaçao

SANTRACO N. V.
Willemstad

Dominican Republic

Electromédica S. A.
Santo Domingo

Ecuador

Siemens S. A.
Quito
Guayaquil

El Salvador

Siemens S. A.
San Salvador

Guatemala

Siemens S. A.
Ciudad de Guatemala

Honduras

Representaciones Electroindustriales S. de R.L.
San Pedro Sula
Tegucigalpa

Jamaica

Meditron Ltd.
Kingston

Martinique

Pénié Medical
Fort-de-France

Mexico

Siemens S A de CV
México, D.F.
Aguascalientes
Apodaca
Chihuahua
Cd. Juárez
Culiacán
Gómez Palacio
Hermosillo
León
Mérida
Puebla
San Juan Cuautlancingo
Tijuana
Tlajomulco de Zuniga
Veracruz
Villa Corregidora

Nicaragua

Siemens S. A.
Managua

Panama

Siemens S. A.
Panama

Paraguay

Rieder & Cia. S. A. C. I.
Asunción

Peru

Siemens S. A.
Lima

Trinidad and Tobago

Biomedical Technologies Ltd.
St. Augustin

United States of America

Siemens Corporation
New York
Allentown
Alpharetta
Arlington
Atlanta
Auburn Hills
Boca Raton
Bridgewater
Brooklyn Park
Camarillo
Charlotte
Columbus
Concord
Cupertino
Danvers
Duluth
Fountain Inn
Gainsville
Hickory
Hoffman Estates
Issaquah
Iselin
Johnson City
Lake Oswego
Lima
Milwaukee
Newport News
Norcross
Oklahoma City
Palo Alto
Piscataway
Princeton
Richardson
Richland
Sacramento
Santa Clara
Santa Fe Springs
San Jose
Sunnyvale
Totawa
Washington
Wendell

Uruguay

Conatel S.A.
Montevideo

Venezuela

Siemens S. A.
Caracas
Barcelona
Maracaibo
Perto Ordaz
Valencia

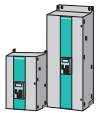

SIMOREG 6RA70 DC MASTER

Appendix

Siemens companies and representatives
outside Europe

Asia

Bahrain

Siemens AG Service Center
Transitec Gulf
Manama

Bangladesh

Siemens Bangladesh Ltd.
Dhaka
Khulna

Brunei

AMS Technologies
Sdn Bhd
Negara
Brunei
Darussalam

India

Siemens Ltd.
Ahmedabad
Bangalore
Calcutta
Chandigarh
Chennai
Coimbatore
Gurgaon
Kaloor
Mumbai
Nashik
Navi Mumbai
New Dehli
Pune
Secunderabad
Vadodara

Indonesia

Representative Office Siemens AG
Jakarta
Batam
Cilegon
Surabaya

Iraq

Siemens AG
Baghdad

Iran

Siemens S.S.K.
Teheran

Israel

Siemens Ltd.
Tel Aviv
Holon
Herzeliya
Ramat Hakhaiyal

Japan

Siemens K. K.
Tokyo
Kobe
Fukuoka
Hiroshima
Ishikawa
Kanagawa
Nagoya
Osaka
Sapporo
Sendai
Yokohama

Jordan

Siemens AG
Jordan Branch
Shmeisani-Amman
Amman

Kazakhstan

Representative of Siemens AG
Almaty

Kirghizstan

Representative of Siemens AG
Bischkek

Korea (Republic)

Siemens Ltd.
Seoul
Changwon
Kyungki-Do

Kuwait

National & German Electrical and
Electronic Services Co.
(NGEECO)
Kuwait

Lebanon

Siemens AG Lebanon Branch
Beyrouth

Malaysia

Siemens Electrical
Engineering Sdn. Bhd.
Petaling Jaya
Kuala Lumpur
Kajang

Myanmar

Siemens Ltd.
Yangon

Nepal

Amatya Enterprises (Pvt.) Ltd.
Kathmandu

Oman

Siemens AG
Muscat Branch
Ruwi
Muscat

Pakistan

Siemens Pakistan
Engineering Co. Ltd.
Karachi
Faisalabad
Islamabad
Lahore
Peshawar
Quetta

People's Republic of China

Siemens Ltd., China
Beijing
Changchun
Chengdu
Chongqing
Chuzhou
Dalian
Fuqing
Fuzhou
Guangzhou
Hangzhou
Jilin
Jinan
Nanghai
Nanjing
Panyu
Rizhao
Shanghai
Shenyang
Shenzhen
Suzhou
Tianjin
Wuhan
Wuxi
Xi'an
Xiaogan City
Zibo

Philippines

Siemens Inc.
Makati City
Pasig City
Cebu
Davao City

Qatar

Arabian Construction
Engineering Company
Doha

Saudi Arabia

Arabia Electric Ltd. (Equipment)
Jeddah
Al Khobar
Riyadh

Singapore

Siemens Advanced Engineering (Pte.) Ltd.
Singapore

Sri Lanka

Dimo Limited
Colombo

Syria

Siemens AG
Damascus Branch
Dasmascus

Taiwan

Siemens Ltd.
Taipei
Taichung
Kaohsiung
Taoyuan Hsien

Thailand

Siemens Limited
Bangkok
Rayong

Turkmenistan

Representative of Siemens AG
Aschgabad

Uzbekistan

Representative of Siemens AG
Tashkent

United Arab Emirates

Siemens Resident Engineers
Dubai
Abu Dhabi

Vietnam

Siemens AG Representation
Hanoi
Ho Chi Minh City

Yemen

Tihama Tractors & Engineering Co. Ltd.
Sanaa
Aden

Australia

Siemens Ltd.
Melbourne
Adelaide
Bayswater
Brisbane
Gladesville
Milton
Pennant Hills
Perth
Silverwater
St. Leonards
Sydney

New Zealand

Siemens (NZ) Limited
Auckland
Wellington

SIMOREG 6RA70 DC MASTER

Appendix

Information and ordering
on the Internet and on CD-ROM

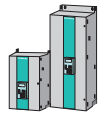

A & D in the WWW



Detailed information about the product range to be used and the services that are available is essential at the planning and project engineering phases of plant automation projects. It is a fact that this information has to be as up-to-date as possible.

For this reason, the Siemens Group Automation and Drives (A&D) provides a comprehensive information service on the World Wide Web that makes it easy for our customers to ac-

cess all the necessary information.

You will find everything you need to know about products, systems and service contracts at:

<http://www.siemens.de/automation>

Product selection with the interactive catalogs



Providing comprehensive information and user-friendly interactive functions:

The interactive catalogs, CA 01 and ET 01, featuring over 80000 products, provide a comprehensive overview of the Siemens Automation and Drives product spectrum.

You will find everything that you need to fulfill any task in the fields of automation, controlgear, electrical installation and drives. All the information is embedded in a user-interface that supports easy, intuitive operation.

When you have selected your products, you can submit your order by fax or via an online link at the press of a button.

You will find Information on the interactive catalogs on the Internet at:

<http://www.siemens.de/automation/ca01>

or on CD-ROM:

Automation and Drives, CA 01
Order No.: E86060-D4001-A100-B5
Installation Systems, ET 01
Order No.: E86060-D8200-A107-A2

Easy shopping with the Siemens Mall



The Siemens Mall is the virtual department store of Siemens AG on the Internet. You can access a gigantic product spectrum that is presented clearly and informatively in electronic catalogs.

Data transfer via EDIFACT allows the complete ordering process, from selection to ordering and order tracking, to take place online via the Internet.

Numerous functions are available to you which make the job easier.

Powerful search functions make it easy to find the required products and check their availability immediately. Individual customer discounts and quotations are available online as well as tracking and tracing of your order.

You will find the Siemens Mall on the Internet at:

<http://www.siemens.de/automation/mall>

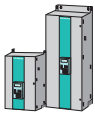

Automation & Drives customer support



Whether you need a service specialist or a spare part, advice from a product expert or just an answer to a question: Contact the Service & Support Team – The team for your success.

Helpline for service and support



You need help and are not sure who to contact. We will ensure that you get assistance quickly.

The helplines guarantee that the right local specialist provides you with technical support. The helpline, for example in Germany, provides assistance 365 days a year round-the-clock in English and German.

Tel.: +49 (0)180 50 50 111

Online support



Our online support provides fast, effective assistance – round-the-clock, worldwide and in five different languages.

Online support offers a wide range of technical information:

- FAQs, Tips and Tricks, downloads and news
- Free manuals
- Helpful programs and software products – payment accepted with the SIMATIC Card

<http://www.siemens.de/automation/service&support>

Field service



Your plant is installed and you need help quickly on site. We have the specialists with the necessary expertise near you wherever you are in the world.

Our dense service network means that you will receive attention quickly and reliably.

In Germany, you can request an expert 365 days a year round-the-clock.

Tel.: 0180 50 50 444 ¹⁾

Naturally we also offer service contracts tailored to your individual needs. Please contact your local Siemens representative for further information.

Spare parts and repairs



Our worldwide network of regional spare parts warehouses and repair shops responds quickly and reliably with the latest in logistics.

In the event of queries concerning repairs or spare parts, please call the following number (in Germany):

Tel.: 0180 50 50 446 ¹⁾

Out of office hours and at the weekend, you can contact our emergency spare parts service under the following number.

Technical support



Technical support with using our products, systems and solutions in the field of automation and drives is available in English and German. Capable, trained and experienced specialists also offer Teleservice and Video Conferencing for particularly difficult problems.

FreeContact – the route to technical support free of charge

- European and African time zones

Tel.: +49 (0)180 50 50 222

Fax: +49 (0)180 50 50 223

E-mail:

techsupport@ad.siemens.de

Mo.-Fr.: 7:00 to 17:00 (CET)

- USA time zones

24h hotline toll-free:

+1 (0)800 241-4453

Tel.: +1 (0)770 740-3505

Fax: +1 (0)770 740-3396

E-mail: drives.support@

sea.siemens.com

Mo.-Fr.: 8:00 to 20:00

(local time: Eastern Time)

- Asian/Australian time zones

Tel.: +65 (0)740-7000

Fax: +65 (0)740-7001

E-mail: drives.support@

sea.siemens.com.sg

Mo.-Fr.: 8:30 to 17:30

(local time: Singapore)

¹⁾Germany only, for local "Länder" telephone numbers visit: <http://www.siemens.de/automation/service&support>



SIMOREG 6RA70 DC MASTER

Appendix

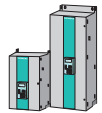

Customer support

Knowledge Base on CD-ROM

For working environments without an online connection to the Internet, an extract of the information provided free of charge is available on CD-ROM (Service & Support Knowledge Base). This CD-ROM contains all the up-to-date product information (FAQs, downloads, Tips and Tricks, news) as well as general information about service and technical support.

You will also find on the CD-ROM a complete text search function and our Knowledge Manager which will help you to locate solutions. The CD-ROM is updated every 4 months.

As with our online service on the Internet, the CD Service & Support Knowledge Base is available complete in 5 languages (English, German, French, Italian and Spanish).

You can order the CD **Service and Support Knowledge Base** from your Siemens contact partner.

Order No.
6ZB5310-0EP30-0BA1

Order over the Internet (using the SIMATIC Card or a credit card) at:

<http://www.siemens.de/automation/service&support>
under "Shop".

SIMATIC Card

You can use the SIMATIC Card to purchase service credit. This credit can then be used to access the technical support services that are subject to charge (FastContact, Service-Line) or to download software products and application examples from the Internet. The SIMATIC Card operates on the same principle as a telephone card.

You can access your credit using the SIMATIC Card number and the SIMATIC Card PIN (both numbers are on the rear of your SIMATIC Card or will be supplied by e-mail when you purchase over the Internet).

On the Internet you can also view the account for your SIMATIC Card at:

<http://www.siemens.de/automation/simatic-card>

The **SIMATIC Card** can be ordered as follows:

From your Siemens contact partner

SIMATIC Card	
Units	Order No.
200	6ES7 997-0AA00-0XA0
500	6ES7 997-0AB00-0XA0
1000	6ES7 997-0AC00-0XA0

Validity: 2 years from date of purchase

On the Internet in conjunction with a credit card, the SIMATIC Card can be used immediately:

<http://www.siemens.de/automation/simatic-card>

Tel.: +49 (0)911 895 7777
Fax: +49 (0)911 895 7001

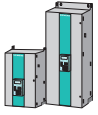

SIMOREG 6RA70 DC MASTER

Appendix

Notes

A

SIMOREG 6RA70 DC MASTER

Appendix

Conditions of sale and delivery, export regulations

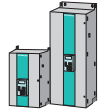

In Germany

Subject to the General Conditions of Sale as well as the General Conditions of Supply and Delivery for Products and Services of the Electrical and Electronics Industry.

For Export

Subject to the General Conditions of Supply and Delivery for Products and Services of the Electrical and Electronics Industry and to any other conditions agreed upon with the recipients of catalogs/price lists.



Software products are subject to the General Licence Conditions for Software Products for Automation and Drives.



Prices are listed in € (Euro) ex delivery point, excluding packaging.

Turnover tax (VAT) is not included in the prices. It will be added according to legal provisions at the applicable rate.

We reserve the right to adjust prices and shall charge the prices applying on the date of delivery.

Notes

All dimensions in this catalog/price list are in mm. The illustrations are for reference only.

We reserve the right to make changes, in particular to the specified values, dimensions and weights, unless specified otherwise on the individual pages of this catalog/price list.

Export regulations

The products listed in this catalog/price list may be subject to European/German and/or US export provisions.

Any export requiring approval is therefore subject to authorization by the relevant authorities.

For the products listed in this catalog/price list, the following export regulations must be adhered to in accordance with currently valid regulations.

AL	Number of the <u>German export list</u> Products with a code other than "N" must be approved for export. The export codes of the respective data medium must also be adhered to for software products. Goods labeled with " <u>AL not equal to N</u> " are subject to European or German export authorization when being exported out of the EU.
ECCN	Number of US export list (<u>Export Control Classification Number</u>) Products with a code other than "N" require approval for re-export to certain countries. The export codes of the respective data medium must also be adhered to for software products. Goods labeled with " <u>ECCN not equal to N</u> " are subject to US reexport authorization.

Even without a label, or with label "AL: N" or "ECCN: N", authorization may be required due to the final whereabouts and purpose for which the goods are to be used.

The AL and ECCN export codes specified in our confirmations, delivery notes and invoices apply.

Subject to change without prior notice.

Responsible for
Technical contents:
Siemens AG, A&D LD M PM, Nuremberg
Editors:
Siemens AG, A&D PT 5, Erlangen

A

Siemens AG
Automation & Drives Group
[Large Drives Division](#)
PO Box 4743, 90025 Nuremberg
Germany
<http://www.siemens.de/automation/ld>

Order No.
E86060-K5121-A111-A1-7600
Printed in the Federal Republic of Germany
KG K 0901 10.0 SV/E 164 En/122358

Catalogs of the Automation and Drives Group (A&D)

Further information can be obtained from our branch offices listed in the appendix of this catalog

Automation and Drives	<i>Catalog</i>		
Interactive catalogs on CD-ROM			
• Components for Automation & Drives	CA 01		
• Installation Systems	ET 01		
Analysis Systems			
Gas Analysis Equipment	PA 10		
Components for Sample Preparation	PA 11		
Liquid Analysis	PA 20		
Drive Systems			
<u>Variable-Speed Drives</u>			
DC Motors	DA 12		
SIMOREG Chassis Converters	DA 21		
SIMOREG Static Converter Cabinets	DA 22		
SIMOVERT PM Modular Converter Systems	DA 45		
SIEMOSYN Motors	DA 48		
MICROMASTER 420/440 Converters	DA 51.2		
COMBIMASTER 411/MICROMASTER 411	DA 51.3		
SIMOVERT A Current-Source DC Link Converters	DA 62		
SIMOVERT MV Medium-Voltage Drives	DA 63		
MICROMASTER, MIDIMASTER	DA 64		
Voltage-Source DC Link Converters			
SIMOVERT MASTERDRIVES	DA 65		
Voltage-Source DC Link Converters			
SIMOVERT P Voltage-Source DC Link Converters	DA 66		
SIVOLT AC and Three-Phase Power Controllers	DA 68		
SITOR Thyristor Assemblies	DA 91		
SITOR Units and Static Converter Cabinets	DA 92		
Chokes	DA 93		
SITOR Semiconductor Protection Fuses	DA 94		
SITOR Control Devices	DA 95		
SIMADYN C Control System	DA 97		
MODULPAC C Control System	DA 98		
SIMADYN D Digital Control System	DA 99		
<u>Drive Systems for Machine Tools SIMODRIVE</u>	NC 60		
• AC Main Spindle Motors 1FE1, 1PH2, 1PH3, 1PH4,			
• AC Servomotors 1FK6, 1FT5, 1FT6			
• Linear Motors 1FN1, 1FN3			
• Converter System SIMODRIVE 611			
• Converter Systems SIMODRIVE POSMO A/CD/CA/SI			
<u>Low-Voltage Three-Phase Motors</u>			
• Project Manual	M 10		
• Squirrel-Cage Motors	M 11		
<u>High-Voltage Three-Phase Motors</u>	M 2		
<u>Starters and Resistor Units</u>	AW 1		
<u>Drive and Control Components for Lifting Gear</u>	HE 1		
Automation Systems for Machine Tools			
Complete Catalog SINUMERIK & SIMODRIVE	NC 60		
Cables, Connectors and System Components	NC Z		
SIMATIC Industrial Automation Systems			
SIMATIC PCS Process Control System	ST 45		
SIMATIC S5/PC/505 Automation Systems	ST 50		
Components for Totally Integrated Automation	ST 70		
SIMATIC PCS 7 Process Control System	ST PCS 7		
Industrial Communication and Field Devices	IK PI		
Installation Systems			
Characteristic Curves of LV Fuses (see CD-ROM ET 01)			
<u>N System</u>	I 2.1		
STAB Wall-Mounting Distribution Boards	I 2.31		
SIKUS Floor-Mounting Distribution Boards	I 2.32		
SIPRO Meter Cabinet Catalogs	I 2.33/01 to I 2.33/12		
Busbar System 8PU	I 2.36		
DELTA Programs	I 2.4		
SITRAIN Information and Training	<i>Catalog</i>		
Courses and Computer Based Training	ITC		
SIMATIC HMI Human-Machine Interface Products and Systems	ST 80		
Systems Engineering			
Power Supplies SITOP power	KT 10.1		
System Cables SIMATIC TOP connect	KT 10.2		
MOBY identification systems	KT 21		
Industrial Microcomputers SICOMP	KT 51		
Industrial Microcomputers SICOMP SMP	KT 52		
Printers and Monitors	KT 61		
Cabinet Packaging System for SIMATIC PCS 7	KT 71		
Controlgear, Switchgear and Systems			
Low-Voltage Controlgear, Switchgear and Systems	NS K		
Communication-Capable Controlgear, Switchgear for Load Feeders, SIRIUS 3R, SIGUARD Safety Systems, Control and Signaling Devices, Switchgear for Power Distribution, Transformers and Power Supplies, Control Switches, Terminal Blocks			
BERO - Sensors for Automation	NS BERO		
Supplementary Catalog	NS E		
Supplementary Range, Superseded Devices, Spare Products and Systems for Low-Voltage Power	NS PS		
SENTRON WL	NS WL		
SICUBE System Cabinets 8MC and 8MF	NV		
Fans	V		
Power Supplies & Components for Drives (Catalog)	PD		
TELEPERM M Process Control System			
AS 235, AS 235H and AS 235K Automation Systems	PLT 111		
AS 388/TM and AS 488/TM Automation Systems	PLT 112		
OS 525 Operating and Monitoring System	PLT 122		
Operating and Monitoring with WinCC/TM	PLT 123		
CS 275 bus system	PLT 130		
Process Engineering			
Field Instruments for Process Automation	FI 01		
Measuring Instruments for Pressure, Differential Pressure, Flow, Level and Temperature, Positioners and Liquid Meters			
SIWAREX Weighing Systems	KT 30		
Analog Indicators and Limit-Value Monitors, Standard Flush-Mounting Instruments	MP 12 B		
Digital and Bargraph Indicators, Standard Flush-Mounting Instruments	MP 12 D		
Process Recorders and Accessories	MP 20		
SIPART, Controllers and Software	MP 31		
MASTERGUARD	USV		
Uninterruptable Power Supplies			
Vacuum Pumps/Compressors			
Oil-Free Vacuum Pumps, Compressors, Radial-Flow Fans	PV		
SIPOS Electrical Actuators			
Electrical Rotary, Linear and Part-Turn Actuators	MP 35		
Electrical Rotary Actuators for Nuclear Power Plants	MP 35.1/2		
System Solutions for Industry			
Combined Catalog: Applications and Products for Automation Solutions in the Plastics Industry	SL 01		
• With SIMATIC S7	SL 10		
• With SIMATIC S5	ST 58		

Siemens AG
Automation and Drives Group
Large Drives Division
P.O. Box 47 43, 90025 Nuremberg
Germany
<http://www.siemens.de/automation/ld>

Siemens Aktiengesellschaft

Order No.: E86060-K5121-A111-A1-7600

